

Pact series

# EvoPact HVX

Medium Voltage Distribution

Catalog 2021

Vacuum circuit breaker up to 24 kV  
Embedded Pole





# Same technology, same offer, simpler names

We're making it easier for you to navigate across the wide range of our world-class digital products and select the offers that are right for you and your needs with confidence.

## EcoStruxure Architecture

To enable brand consistency, relevance and impact, we are reinforcing our EcoStruxure™ architecture and digital customer lifecycle tools to help ensure a seamless experience from the CAPEX to OPEX phases of each project, bridging our entire ecosystem of partners, services providers and end users.

EcoStruxure is our IoT-enabled open and interoperable system architecture and platform. EcoStruxure delivers enhanced values around safety, reliability, efficiency, sustainability and connectivity for our customers. EcoStruxure leverages advancements in IoT, mobility, sensing, cloud, analytics, and cybersecurity technologies to deliver Innovation At Every Level from Connected Products, Edge Control, Apps, and Analytics & Services: our IoT technology Levels.

Old names	New names
Ecodial	EcoStruxure Power Design
Ecoreal	EcoStruxure Power Build
Ecoreach	EcoStruxure Power Commission
MasterPact MTZ mobile App/Easergy mobile App	EcoStruxure Power Device App

## Pact and Set Series

Featuring outstanding medium-voltage (MV) and low-voltage (LV) switchboards, motor control centers and power distribution solutions for high-performance power applications, Schneider Electric's Pact and Set Series are best-in-class solutions based on high levels of safety and an optimized footprint. Built on a modular architecture and incorporating smart connected devices for maximum safety, reliability, performance and energy efficiency, the Set Series is delivered to customers directly from our Schneider Electric plants or via a global network of licensed partner panel builders, who are trained and audited to provide quality equipment and support.

Old names	New names
HVX	EvoPact HVX
Premset	PremSet
Compact	ComPact
Masterpact	MasterPact
Transferpact	TransferPact
Fupact	FuPact

# General contents

---

Overview	6
----------	---

---

Range description	20
-------------------	----

---

Function and modules description	28
----------------------------------	----

---

Dimensions	44
------------	----

---

Product references	56
--------------------	----

---

L-Frame cradle	66
----------------	----

---





# Your needs

# EvoPact HVX answers



## Safety

### Safety

- State-of-the-art design
- Manufacturing controls
- Operation with mechanical interlocks
- Remote control



## Reliability

### Reliability

- Compliance with the standards
- Fully type-tested equipment
- Limited maintenance

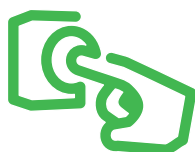

## Ease of use

### Ease of use

- Wide choice of configurations
- Easy integration
- Customer support

# Overview

# Overview

Field of application	8
Safety	9
Reliability	12
Ease of use	13
EcoStruxure Ready™ solution	15
A comprehensive solution	16
Schneider Electric services	17
Sustainability	18



EvoPact HVX offers a wide range of performance levels. It controls heavy-duty tasks in harsh conditions, low temperatures, and vibrations under normal, inductive, and capacitive loads.

## The result of a sustained development effort for application in air-insulated switchgear units

The EvoPact HVX series of vacuum circuit breakers is the result of Schneider Electric's long lasting experience in the medium-voltage field.

The EvoPact HVX series offers a proven state-of-the-art design to meet your specifications for power switching devices in air-insulated switchgear.

- A fixed, frontal type
- A withdrawable, frontal type

The EvoPact HVX operating mechanism gives the device an opening and closing speed that is independent of the operator whether the command is electrical or manual.

It carries out reclosing cycles and is automatically recharged by a geared motor after each closing.

It also ensures that the open order always takes priority over the close order. In the event of permanent opening and close orders, it has to maintain the circuit breaker in the open position as long as the open order is active. Once the open order has been canceled, the close order has to be interrupted then reactivated to enable closing of the circuit breaker.

Easy integration in modern air-insulated switchgear makes EvoPact HVX the right choice for panel builders and end users. An Integration Guide is available containing instructions on how to do so.

## Applications

The circuit breaker is the core component of medium voltage switchgear. The EvoPact HVX offer enables panel builders to design switchgear solutions helping to control and to protect cables, transformers, motors, or generators.

It is widely used in many industries, including power distribution, power generation, nuclear power, oil and gas, mining and metals, and transport.

PM109084



PM109086

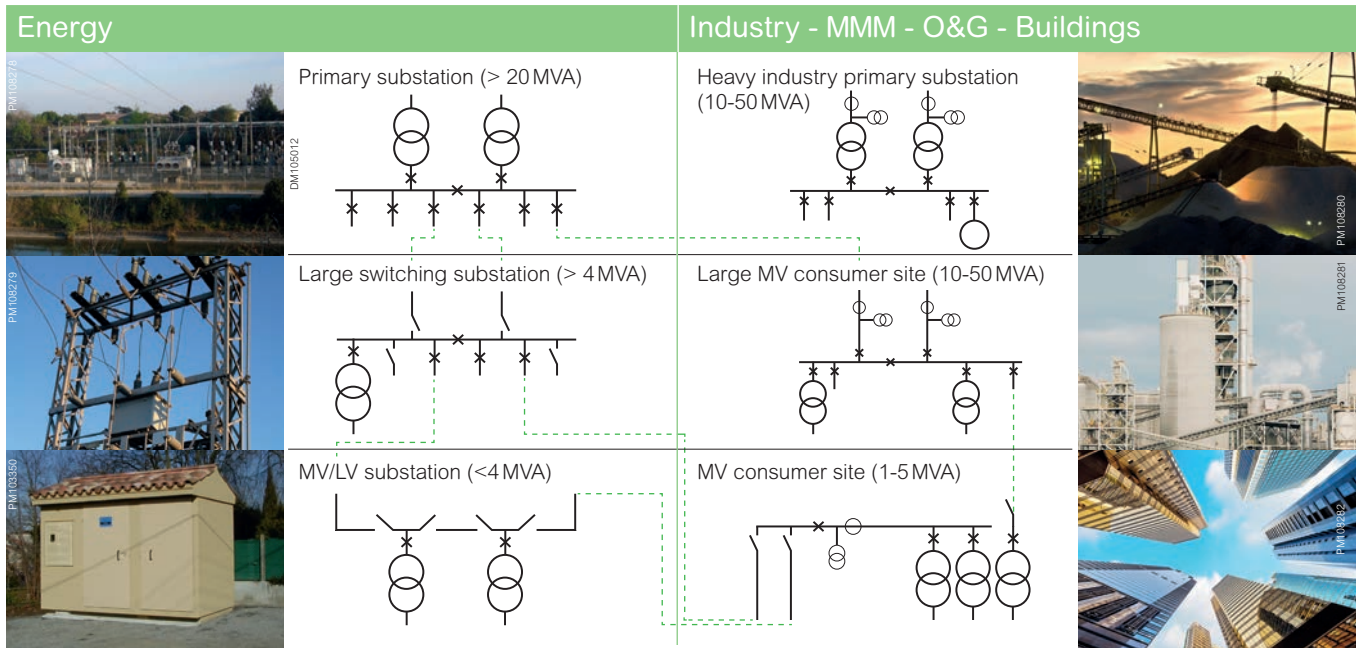

# Safety

Protection of people and equipment is our top priority

## State-of-the-art design

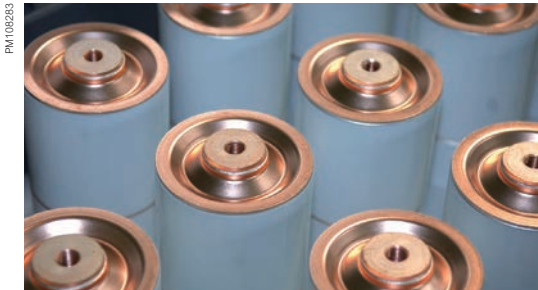

PM100283

## Vacuum interrupter

Schneider Electric's VG range of vacuum interrupters have been developed using the latest computer modeling tools to achieve optimized designs. Based on advanced one-stop sealing technology, the VG offer minimizes artificial pollution during the production process.

Based on our patented design and comprehensive knowledge of vacuum interrupter technology, Schneider Electric's vacuum interrupter is a standout product in the medium voltage field with its high reliability, compact size, and long service life.

The special geometry of the contacts and the choice of material used ensures limited duration of the arc and thus helps to reduce thermal and dielectric stress.

### Benefits of vacuum interrupters

- Protection of contacts against oxidation and contamination in sealed vacuum
- Low contact mass to limit the energy of the drive and to allow high mechanical endurance
- Maintenance-free
- Environmentally-friendly



PM100284



PM100285

## Embedded-pole construction

The embedded pole is another of Schneider Electric's contributions to medium voltage products, with its 10 years' plus experience in design and manufacture, and it has been tried and tested in the field for many years. Employing the embedding technology, it completely integrates the vacuum interrupter, the main circuit, and the insulated shaft in an epoxy pole to help protect the main circuit from the outside.

This gives the pole optimum environmental adaptability, since the circuit breaker can function normally under harsh conditions.

### Benefits of embedded poles

- Compact and robust design
- Protection against vibration, dust, and humidity
- High dielectric strength
- Compact dimensions and possible use in high altitude
- Sealed for life

# Safety

Protection of people and equipment is our top priority

DM100392

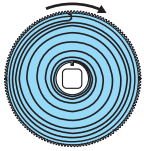

Drive spring-charging mechanism

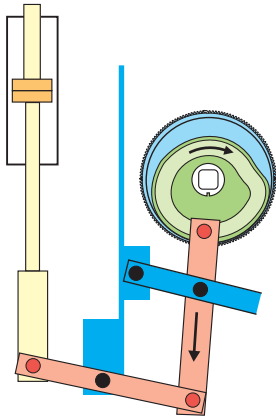
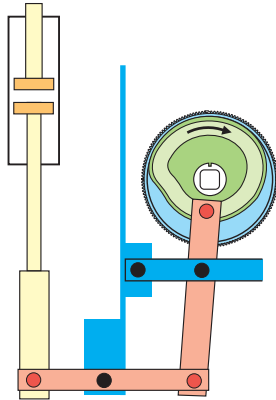

## Operating mechanism

The operating mechanisms have been simplified to increase reliability and give extended life with very low maintenance.

Instead of the traditional spring operating mechanism, the EvoPact HVX series incorporates a single-shaft system and only one torsion spring, reducing the number of parts and increasing reliability.

The cam output from 3 independent phases is ideal for the vacuum switch.

The transmission mechanism's one-step output and the special axletree design offers optimum transmission efficiency that helps save energy and provides a stable, reliable mechanism.

### Operating principle

Energy is stored in the spiral spring by means of the electric motor or manual crank. Opening and closing of the vacuum interrupter is controlled by the cam; upon closing, the spring automatically restores the energy for an integrated automatic on/off operating cycle.

The on/off storage mechanism, with its special mechanism, can absorb the excess energy of the drive mechanism through a quick on/off operation.

The operating mechanism has electric and manual charging devices. The relevant interlock prevents manipulation errors after energy storage.

PM100286



## Robust manufacturing controls

EvoPact HVX is manufactured in compliance with ISO 9001 certified by Bureau Veritas.

The following quality controls are implemented to ensure that each product delivered to panel builders has the same performance as the unit type tested:

- Inspection of every incoming batch of critical components with 3D device dimension checks
- Routine tests on all products:
  - Dielectric tests on the main circuit
  - Tests on auxiliary and control circuits
  - Measurement of the resistance of the main circuit
  - Design and visual checks
  - Mechanical operating tests
- Regular mechanical tests on circuit breaker samples are performed until the device breaks down



# Safety

Protection of people and equipment is our top priority

The IEC (1) standard stipulates: "Select equipment that minimizes the risks to personnel from improper operation (for example, fast acting earthing switches on lines, motor operators to allow remote operation)".

The right choice of components, such as withdrawable racking trolley, vacuum interrupter, and operating mechanism, is crucial to fulfil this IEC recommendation.

(1) IEC 62271-1: Edition 2011

## Safe operation

The operating interface clearly indicates the status of the circuit breaker. Any maloperation is prohibited through robust mechanical interlocks.

### Interface operation

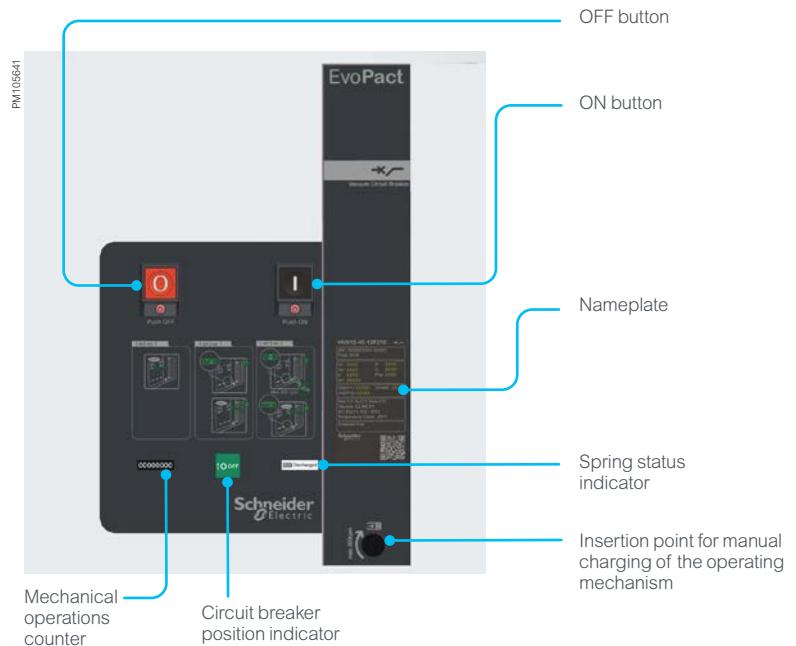

## Racking trolley

The racking trolley moves the circuit breaker from the disconnected position to the connected position and vice versa. The racking operation can be done either by rotating a lever on the front of the switchgear with the door closed, or remotely by activating an electrical command from the control room.

The EvoPact HVX racking trolley has a robust interlocking system with the LV plug and the circuit breaker. It can be equipped with an electric motor module for remote racking from the control room.

The materials used to manufacture EvoPact HVX racking trolley sub-assemblies have been selected and designed to operate 1 000 cycles under the conditions defined by the IEC standard.

## Remote control

Remote operation is recommended as it allows convenient operation from a reasonable distance.

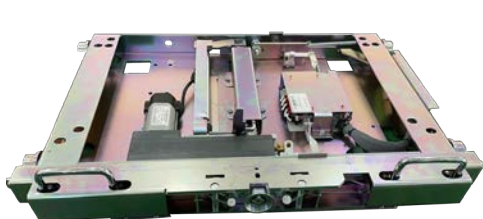



## Wide choice of configurations with modular design

EvoPact HVX offers a wide choice of performance levels (up to 50 kA and 4,000 A) within one circuit breaker family, thus providing panel builders with a high degree of standardization in their switchgear design.

## High-performance breaking devices

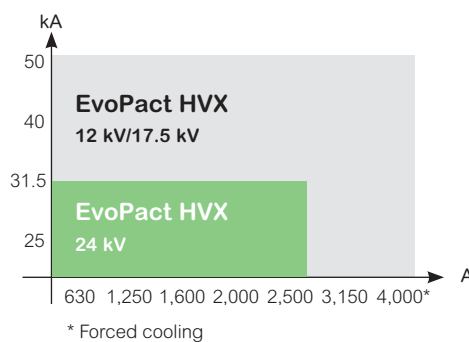

## Easy integration, with simple and standard interfaces

- Common dimensions based on a modular design ensure easy integration into various switchgear designs
- The breaker offers installation flexibility
- Panel builders can use their own trolley design to make it a withdrawable solution

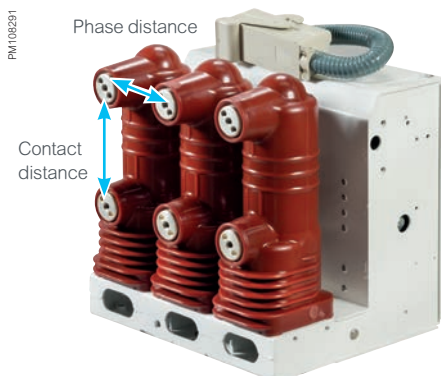

### EvoPact HVX 12/17.5 kV

		Phase distance (mm)		
		150	210	275
Contact distance (mm)	205	•	•	•
	310	-	•	•

### EvoPact HVX 24 kV

		Phase distance (mm)	
		210	275
Contact distance (mm)	310	•	•



Schneider Electric offers best-in-class support to customers using EvoPact HVX embedded pole circuit breakers.



## Technical and commercial support

Schneider Electric offers extensive technical and commercial support to panel builders, including expert advice on how to customize EvoPact HVX, how to integrate it in switchgear, how to prepare switchgear for testing in the laboratory, how to analyze the results from type tests to improve switchgear design, special commercial conditions for circuit breakers needed to verify the technical performance of EvoPact HVX in assembled switchgear, as well as dedicated training documents and other support materials.

Please contact your Schneider Electric sales representative for more information.

## Customer support

### Online document repository

A QR code on the front of the EvoPact HVX enables customers to easily download various online documents:

- User guide
- Receipt guide
- Catalog

### Customer Care Center

Schneider Electric has set up call centers and e-mail contacts in more than 190 countries to provide a rapid response to customer inquiries. Personnel in the country using EvoPact HVX are trained to provide qualified answers to customer questions.

### Spare parts

Under Schneider Electric's spare parts management policy, EvoPact HVX parts will be available for at least 12 years after delivery of the product to the customer.

### Services

A service contract for the switchgear room can be offered by the local Schneider service team with packages such as predictive maintenance, preventive maintenance, 24/7 hotline, emergency on-site intervention, and emergency spare part delivery.

The availability of the service plan offers varies in different countries.



## Scalability with fit-for-purpose solutions

For customers who would like a digital approach, we propose an efficient and cost-effective alternative to breaker, cable and busbar thermo scanning using temperature wireless sensors and a smart phone app.



### Easergy TH110

#### Wireless Thermal Sensor

**A battery-less sensor, helping ensure continuous thermal monitoring to detect potential loose connections of:**

- Cable connections
- Busbar connections
- Circuit breaker arms

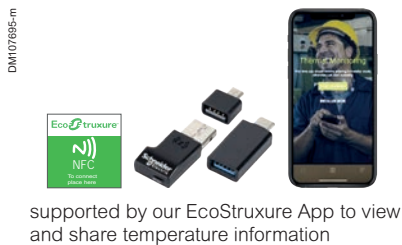

Local, on demand connectivity enables:

- Nearby thermal monitoring on your smartphone up to 10 m from your switchgear
- Fast access to documentation via QR code

## Enhanced for modern MV distribution

The connected switchgear is the perfect choice for intelligent distribution, helping to secure both new and existing operations. Thanks to its innovative tools and IoT capabilities, your switchgear can start to become future-ready.

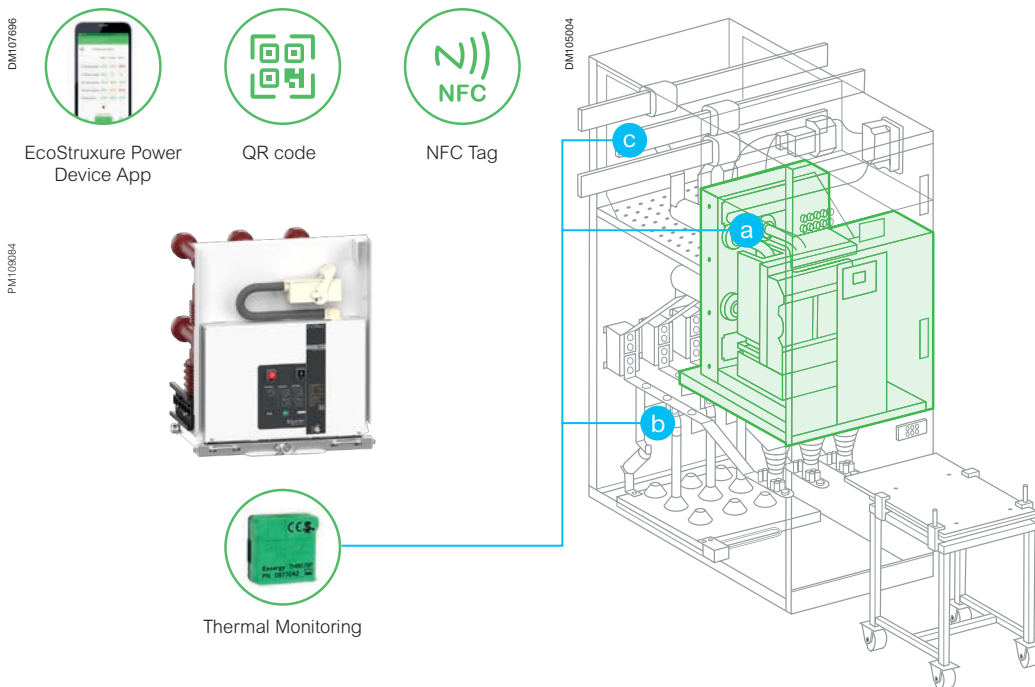

Schneider Electric product portfolios include a wide choice of multi-function relays to be used together with EvoPact HVX, to build a consistent solution for protection, control, and monitoring.

## PowerLogic protection and control relays

PowerLogic smooths the power supply, protects the network, the installation and the operator by improving the power factor and hence the quality of the power. Complete new range of connected protection relays designed to modern IEC and other global standards, offering a wider scope of protection, while extending the limits of control and monitoring:

- Improved safety and security of your electrical network
- More flexibility and ease of use at every step of the products' life-cycle with a single setting software across the range (Easergy Pro)
- Keeping a best-in class reliability, ensured with strengthened type tests and validation processes

### Easergy P1

Ultra-compact, single-function protection relay, that addresses simple applications such as overcurrent protection. Easergy P1 offers a new set of digital tools to gain efficiency from ordering to commissioning to maintenance time, while ensuring a best-in class quality level. It's ease of installation and commissioning will be a key asset for electrical panel-builders.

### Easergy P3

Multi-function protection relay range, addressing a wider scope of applications for building, industry and utility. Easergy P3 is natively connected with 9 communication protocols including IEC 61850 and brings new possibilities of protection, control and monitoring keeping a priority focus on efficiency and time-saving for all the project's stakeholders.

### Easergy P5

The latest innovative protection relay range, extending the boundaries of usability, maintainability and operational efficiency. Easergy P5 offers the core protection functions for mission critical applications, including Arc Flash protection and Cyber security that reduce the Mean Time to Repair (MTTR) to less than 10 minutes and significantly increase operational efficiency.

## PowerMeter and circuit monitors

The PowerLogic PowerMeter replaces a whole set of basic analogue meters.

This cost-effective, high-performance meter provides a full range of accurate true-rms metering values.

The PowerLogic series 3000/4000 Circuit Monitor is designed for critical power users and large energy consumers, to provide the information needed to confidently enter the evolving world of deregulation.

It can be adapted to meter almost any time-of-use or real-time rate.

## VAMP arc fault protection relay

The VAMP arc protection unit detects an arc flash in an installation and trips the feeding breaker. The arc flash functionality improves the safety of the application using the long experience in a world wide leader of arc fault solutions.



Easergy P1

PM105643



Easergy P3

PM107987



Easergy P5



Power Meter

PE57123



PM105362



VAMP 125



# Schneider Electric Services

Greater peace of mind throughout your installation lifecycle

How can you cut costs and improve performance at the same time?

When it comes to your electrical distribution infrastructure, the answer is straightforward: get professional expertise.

## Lifecycle services

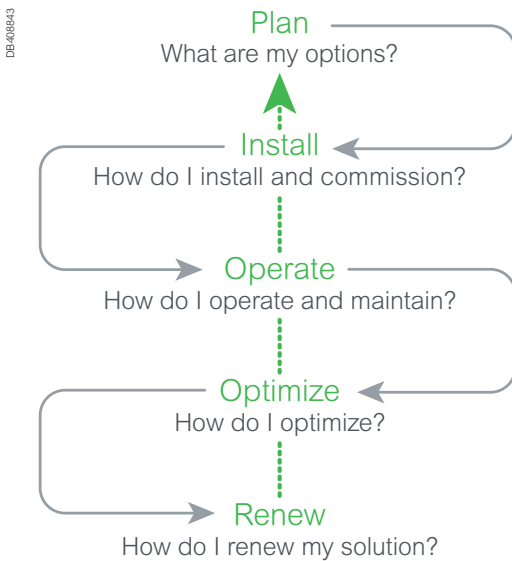

When it comes to your electrical distribution installation, we can help you:

- Mitigate risk and limit downtime
- Keep equipment up to date and extend lifespan
- Cut costs and increase savings
- Improve your return on investment

### CONTACT US!

<https://www.se.com/en/work/services/>

## Plan

Schneider Electric helps you plan the full design and execution of your solution, looking at how to make your process more dependable and optimize time:

- **Technical feasibility studies:** Design a solution in your environment
- **Preliminary design:** Accelerate turnaround time to reach a final solution design

## Install

Schneider Electric will help you to install more efficient, more reliable solutions based on your plans.

- **Project management:** Complete your projects on time and within budget
- **Commissioning:** Ensure your actual performance matches the design, through on-site testing and commissioning, tools, and procedures

## Operate

Schneider Electric helps you maximize your installation uptime and control your capital expenditures through its service offering.

- **Asset operation solutions:** Provide the information you need to enhance installation performance, and optimize asset maintenance and investment
- **Advantage service plans:** Customize service plans that include preventive, predictive, and corrective maintenance
- **On-site maintenance services:** Deliver extensive knowledge and experience in electrical distribution maintenance
- **Spare parts management:** Ensure availability of spare parts and an optimized maintenance budget for your spare parts
- **Technical training:** Build necessary skills and competencies to properly operate your installations

## Optimize

Schneider Electric proposes recommendations to help with availability, reliability, and quality.

- **MP4 electrical assessment:** Define an improvement and risk management program

## Renew

Schneider Electric's solutions extend the original life of your system, while providing upgrades.

# Sustainability

## Green Premium™ program

PM106239



An industry leading portfolio of offers delivering sustainable value



More than 75% of our product sales offer superior transparency on the material content, regulatory information and environmental impact of our products:

- RoHS compliance
- REACH substance information
- Industry leading # of PEP's\*
- Circularity instructions

The Green Premium program stands for our commitment to deliver customer valued sustainable performance. It has been upgraded with recognized environmental claims and extended to cover all offers including Products, Services and Solutions.

### CO<sub>2</sub> and P&L impact through... Resource Performance

Green Premium brings improved resource efficiency throughout an asset's lifecycle. This includes efficient use of energy and natural resources, along with the minimization of CO<sub>2</sub> emissions.

### Cost of ownership optimization through... Circular Performance

We're helping our customers optimize the total cost of ownership of their assets. To do this, we provide IoT-enabled solutions, as well as upgrade, repair, retrofit, and remanufacture services.

### Peace of mind through... Well-being Performance

Green Premium products are RoHS and REACH compliant. We're going beyond regulatory compliance with step-by-step substitution of certain materials and substances from our products.

### Improved sales through... Differentiation

Green Premium delivers strong value propositions through third-party labels and services. By collaborating with third-party organizations we can support our customers in meeting their sustainability goals such as green building certifications.

DM107341



Discover what we mean by green  
**Check your products!**

\*PEP: Product Environmental Profile (i.e. Environmental Product Declaration)



PM1102393

### Long-term environmental approach

PM105397



Schneider Electric is committed to a long-term environmental approach. The production site is certified to ISO 14001.

The materials used in EvoPact HVX, insulators, and conductors are identified and can easily be separated and recycled, as detailed in the "Product Environment Profile" file. An end-of-service-life manual details procedures for dismantling and processing components.

PM1102397



EvoPact HVX fulfills the European regulations of RoHS (Restriction of Hazardous Substances) and REACH (Registration, Evaluation, Authorisation and Restriction of Chemicals).

# Range description

# Range description

---

<b>Overview</b>	<b>22</b>
<b>Selection guide</b>	<b>26</b>
EvoPact HVX 12 kV	26
EvoPact HVX 17.5 kV	27
EvoPact HVX 24 kV	27

---

PM105642



## Fixed and withdrawable types

Rated voltage (kV)	Rated short-circuit current (kA)	Rated current (A)
12	25	630/1,250/1,600/2,000/2,500/3,150/4,000*
	31.5	
	40	
	50	
17.5	25	630/1,250/1,600/2,000/2,500/3,150/4,000*
	31.5	
	40	1,250/1,600/2,000/2,500/3,150/4,000*
	50	
24	25	630/1,250/1,600/2,000/2,500
	31.5	

\* Forced cooling

PM109397



Fixed type

## EvoPact HVX fixed type

The EvoPact HVX fixed type is equipped with drilled and threaded copper connection terminals at the top and bottom.

The shape and dimensions of conductors are determined by the panel builder according to the dielectric withstand and temperature rise characteristics of the whole connection system.

6 insulating sleeves are delivered with circuit breaker as loose components. And they need to be installed by the panel builder.

Please contact your Schneider Electric sales representative to request an EvoPact HVX Integration Guide for more information.

PM109291

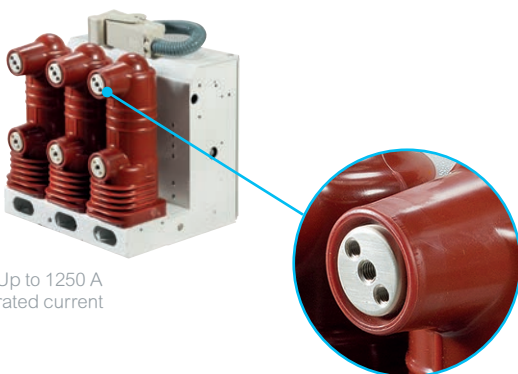

Up to 1250 A rated current

PM109299

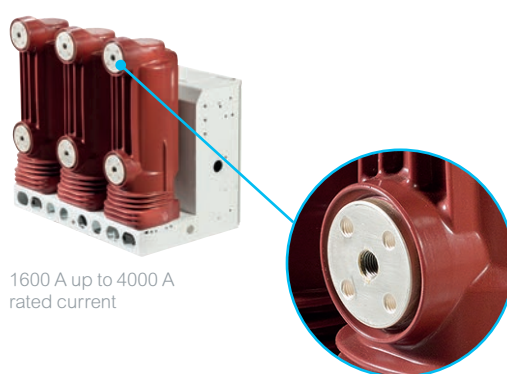

1600 A up to 4000 A rated current



PM109388



Withdrawable type

## EvoPact HVX withdrawable type

The EvoPact HVX withdrawable type requires a racking trolley, arms, and tulip-type contacts for connection to the switchgear power circuit, and a LV connector to connect the auxiliary circuits.

PM105266



Racking trolley

### Racking trolley

The EvoPact HVX racking trolley allows panel builders to design switchgear solutions with enhanced safety features. It has a robust interlocking system with the switchgear door, LV plug, circuit breaker, and earthing switch. It can be equipped with an electric motor module for remote racking from the control room.

Arms

PM105300



Tulip-type contacts

### Arms

The shape and size of EvoPact HVX arms depend on the rated lightning impulse withstand voltage and the rated normal current.

### Tulip-type contacts

The shape of EvoPact HVX contacts is tulip-type. The size depends on the rated current to provide a maximum contact surface optimizing heat dissipation and offering good compensation characteristics for electrodynamic forces. The panel builder needs to provide fixed-type contacts with the correct shape, tolerance, and material characteristics compatible with the EvoPact HVX tulip-type contacts.

PM105301

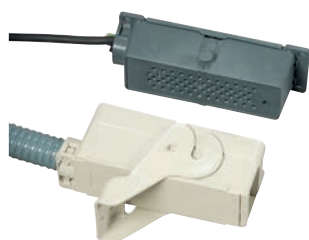

LV connector,  
cubicle side

LV connector,  
circuit breaker  
side

### LV connector

The EvoPact HVX LV connector enables the auxiliary circuits to be connected to the switchgear control cabinet with the circuit breaker in either the disconnected or the service position.

The EcoStruxure™ architecture and interoperable technology platform bring together energy, automation, and software. It provides enhanced value around safety, reliability, efficiency, sustainability and connectivity.

### Connected Product solutions

In the Connected Products layer, EvoPact HVX is a fundamental component of our EcoStruxure™ Ready architecture.

Currently EvoPact HVX comes with a best digital experience in its class, in order to help you confront new challenges and objectives.

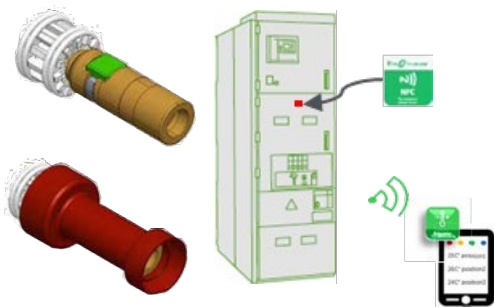

### Temperature intelligent monitoring

- Equipped with our intelligent PowerLogic Thermal Tag wireless sensors to detect abnormal conditions.
- Retains the same cabinet size as conventional circuit breakers, with embedded sensors for enhanced safety.
- Sensors are self-powered, wireless and maintenance free to simplify operations.
- Simply scan an NFC or QR code at the front of the switchboard using EcoStruxure Power Device App, it's Thermal Monitoring features will do the rest.
- Use wireless communication to maintain a safer distance from live equipment including inaccessible points.

### Thermal Monitoring availability

	Availability
Monitoring of circuit breaker - 6 sensors	●
Monitoring of busbar - 3 sensors	○
Monitoring of cable - 3 sensors	○
EcoStruxure NFC tag	●
EcoStruxure Power Device App (Thermal Monitoring feature)	●

● Standard    ○ Optional

### Main electrical characteristics according to IEC 62271-100: 2012-09

Common characteristics					
Rated voltage	Ur	kV	12	17	24
Rated power frequency withstand voltage	U d	kV	28 <sup>(1)</sup>	38	50
Rated lightning impulse withstand voltage	Up	kV	75	95	125
Rated frequency	f	Hz	50/60	50/60	50/60
Rated short circuit breaking current	Isc	kA	25-31.5-40-50	25-31.5-40-50	25-31,5
Rated short circuit making current @50 Hz	I <sub>p</sub>	kA	2,5 I <sub>sc</sub>	2,5 I <sub>sc</sub>	2,5 I <sub>sc</sub>
Rated short circuit making current @60 Hz	I <sub>p</sub>	kA	2,6 I <sub>sc</sub>	2,6 I <sub>sc</sub>	2,6 I <sub>sc</sub>
Rated duration of short circuit	tk	s	3	3	3
Operating sequence					<ul style="list-style-type: none"> <li>• O-0.3s-CO-3 min-CO</li> <li>• O-3 min-CO-3 min-CO</li> <li>• O-0.3s-CO-15s-CO</li> </ul>
Opening time		ms	30-60	30-60	30-60
Arcing time		ms	≤15	≤15	≤15
Closing time		ms	40-70	40-70	40-70
Service temperature		°C	-25 to +40	-25 to +40	-25 to +40
Mechanical endurance			M2	M2	M2
Electrical endurance			E2	E2 <sup>(2)</sup>	E2 <sup>(2)</sup>
Line charging breaking current	A		10	10	10 <sup>(3)</sup>
			C2	C2	C2
Cable charging breaking current	A		25	31.5	31,5 <sup>(3)</sup>
			C2	C2	C2
Single capacitor bank and back-to-back capacitor bank breaking capacity			<sup>(2)</sup>	<sup>(2)</sup>	<sup>(2)</sup>

(1) Please contact Schneider Electric for GOST performance

(2) Please contact Schneider Electric

(3) Only applicable for 25 kA 630 A/1250 A

# Selection guide

## EvoPact HVX 12 kV Fixed and withdrawable type

PM1030988



PM1030984

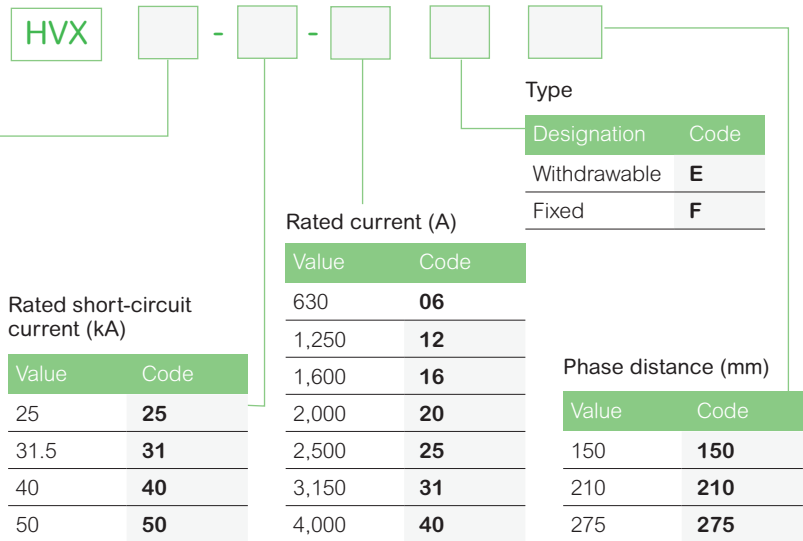

Model 12kV	Fixed	Withdrawable	Rated voltage (kV)	Rated short-circuit current (kA)	Rated current (A)	Phase distance (mm)			Contact distance (mm)	Weight (1) (kg)					
						150	210	275		F	E				
HVX 12-25-06	F	E	12	25	630	•	•	•	205	95	105				
HVX 12-25-12					1,250	•	•	•	205	105	115				
HVX 12-25-16					1,600		•	•	310	175	200				
HVX 12-25-20					2,000		•	•	310	175	200				
HVX 12-25-25					2,500		•		310	195	250				
HVX 12-25-31					3,150		•		310	195	250				
HVX 12-25-40					4,000 *		•		310	195	250				
HVX 12-31-06					F	E	12	31	630	•	•	•	205	95	105
HVX 12-31-12	1,250	•	•	•					205	105	115				
HVX 12-31-16	1,600		•	•					310	175	200				
HVX 12-31-20	2,000		•	•					310	175	200				
HVX 12-31-25	2,500		•						310	195	250				
HVX 12-31-31	3,150		•						310	195	250				
HVX 12-31-40	4,000 *		•						310	195	250				
HVX 12-40-12	F	E	12	40					1,250		•	•	310	175	200
HVX 12-40-16					1,600		•	•	310	175	200				
HVX 12-40-20					2,000		•	•	310	175	200				
HVX 12-40-25					2,500		•		310	195	250				
HVX 12-40-31					3,150		•		310	195	250				
HVX 12-40-40					4,000 *		•		310	195	250				
HVX 12-50-12					F	E	12	50	1,250		•	•	310	195	200
HVX 12-50-16									1,600		•	•	310	195	200
HVX 12-50-20	2,000		•	•					310	195	200				
HVX 12-50-25	2,500		•						310	195	250				
HVX 12-50-31	3,150		•						310	195	250				
HVX 12-50-40	4,000 *		•						310	195	250				

(1) The weight is without packaging and for reference only.

\* Forced cooling

# Selection guide

## EvoPact HVX 17.5 kV and 24 kV Fixed and withdrawable type

Model 17.5 kV	Fixed	Withdrawable	Rated voltage (kV)	Rated short-circuit current (kA)	Rated current (A)	Phase distance (mm)			Contact distance (mm)	Weight <sup>(1)</sup> (kg)	
						150	210	275		F	E
HVX 17-25-06	F	E	17.5	25	630	•	•	•	205	95	105
HVX 17-25-12					1,250	•	•	•	205	105	115
HVX 17-25-16					1,600		•	•	310	175	200
HVX 17-25-20					2,000		•	•	310	175	200
HVX 17-25-25					2,500			•	310	195	250
HVX 17-25-31					3,150			•	310	195	250
HVX 17-25-40					4,000 *			•	310	195	250
HVX 17-31-06	F	E	17.5	31	630	•	•	•	205	95	105
HVX 17-31-12					1,250	•	•	•	205	105	115
HVX 17-31-16					1,600		•	•	310	175	200
HVX 17-31-20					2,000		•	•	310	175	200
HVX 17-31-25					2,500			•	310	195	250
HVX 17-31-31					3,150			•	310	195	250
HVX 17-31-40					4,000 *			•	310	195	250
HVX 17-40-12	F	E	17.5	40	1,250		•	•	310	175	200
HVX 17-40-16					1,600		•	•	310	175	200
HVX 17-40-20					2,000		•	•	310	175	200
HVX 17-40-25					2,500			•	310	195	250
HVX 17-40-31					3,150			•	310	195	250
HVX 17-40-40					4,000 *			•	310	195	250
HVX 17-50-12	F	E	17.5	50	1,250		•	•	310	195	200
HVX 17-50-16					1,600		•	•	310	195	200
HVX 17-50-20					2,000		•	•	310	195	200
HVX 17-50-25					2,500			•	310	195	250
HVX 17-50-31					3,150			•	310	195	250
HVX 17-50-40					4,000 *			•	310	195	250

Model 24 kV	Fixed	Withdrawable	Rated voltage (kV)	Rated short-circuit current (kA)	Rated current (A)	Phase distance (mm)			Contact distance (mm)	Weight <sup>(1)</sup> (kg)	
						150	210	275		F	E
HVX 24-25-06	F	E	24	25	630		•	•	310	175	190
HVX 24-25-12					1,250		•	•	310	175	190
HVX 24-25-16					1,600			•	310	255	280
HVX 24-25-20					2,000			•	310	255	280
HVX 24-25-25					2,500			•	310	255	280
HVX 24-31-06	F	E	24	31	630			•	310	255	280
HVX 24-31-12					1,250			•	310	255	280
HVX 24-31-16					1,600			•	310	255	280
HVX 24-31-20					2,000			•	310	255	280
HVX 24-31-25					2,500			•	310	255	280

<sup>(1)</sup> The weight is without packaging and for reference only.

\* Forced cooling

# Function and modules description



# Function and modules description

Opening and closing functions	30
Charging functions	32
Low voltage connection	33
Racking trolley	34
Locking functions	35
Other complementary devices	36
Secondary wiring diagrams	37

## Operating mechanism

### Opening release F11/F12

The F11/F12 release is used to open the circuit breaker. The release coil is actuated by the auxiliary power supply.

The coil is designed for short operation only; it is therefore routed via an auxiliary switch contact controlled by the circuit breaker shaft, and upon release it interrupts the current circuit.

#### Characteristics

Power supply	V a.c.	110/120*/220/230
	V d.c.	24*/48/60/110/125/220
Operating range	V a.c.	0.85 to 1.1 Ua
	V d.c.	0.7 to 1.1 Ua
Consumption	V a.c.	180 VA
	V d.c.	180 W

\* Please contact Schneider Electric

### Closing release F2

The F2 release is used to close the circuit breaker. The release coil is actuated by the auxiliary power supply.

The coil is designed for short operation only; it is therefore routed via an auxiliary switch contact controlled by the circuit breaker shaft, and upon release it interrupts the current circuit.

#### Characteristics

Power supply	V a.c.	110/120*/220/230
	V d.c.	24*/48/60/110/125/220
Operating range	V a.c.	0.85 to 1.1 Ua
	V d.c.	0.85 to 1.1 Ua
Consumption	V a.c.	180 VA
	V d.c.	180 W

\* Please contact Schneider Electric

### Overcurrent release F3

The F3 release is used to open the circuit breaker in the event of overcurrent or short-circuit.

The power to activate the overcurrent release comes from the current transformer of the high voltage circuit, not from the auxiliary voltage supply. Thus the tripping function of this coil is independent of the auxiliary voltage supply.

#### Characteristics

Rated supply current	A	0.5/1/5
Operating range	A	• < 90% of rated current, it shall not work.
		• ≥110% of rated current, it shall work properly.
Consumption	W	180

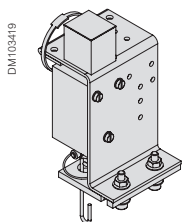
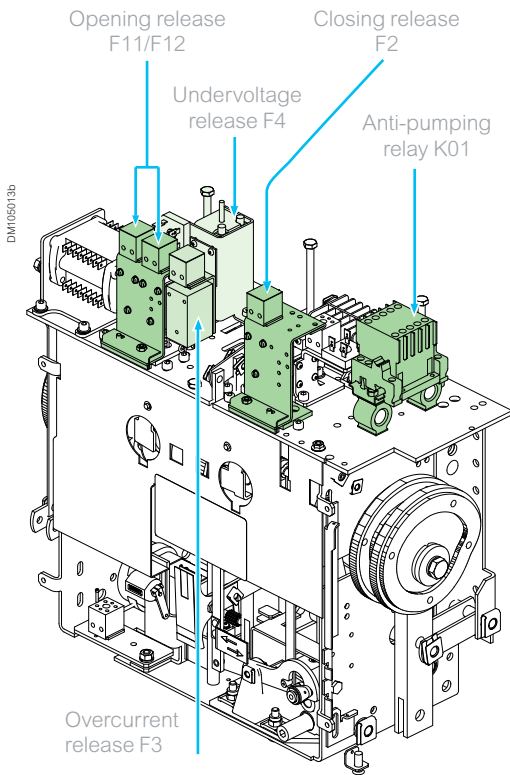

Opening release F11/F12

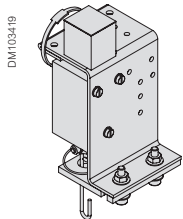

Closing release F2

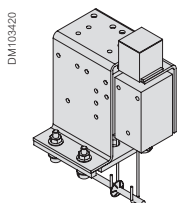

Overcurrent release F3

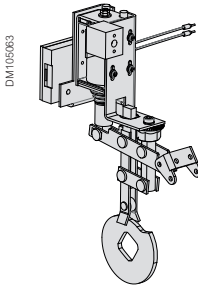

DM103683

Undervoltage release  
F4

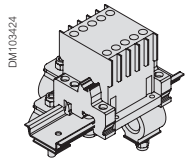

DM103424

Anti-pumping relay  
K01

## Undervoltage release F4

The F4 release opens the circuit breaker automatically, when the auxiliary voltage drops below a certain level. Thus the undervoltage release protects the circuit breaker against a drop or loss of the auxiliary voltage supply.

### Characteristics

Power supply	Vac	-			110	220/230
	Vdc	24	48	60	110/125	220
Operating range	Opening	0.35 to 0 Uop				
Starting consumption (W)	Vac	-			378	334
	Vdc	288	329	400		
Holding consumption (W)	Vac	-			8	7
	Vdc	4	7	6		

## Anti-pumping relay K01

The anti-pumping relay prevents continuous closing and opening of the circuit breaker (anti-pumping).

If both ON and OFF commands are permanently present on the circuit breaker at the same time, the circuit breaker will carry out a CLOSE-OPEN sequence; it remains in this open position until the CLOSE command is discontinued and a new CLOSE command is issued again.

# Charging functions

## Circuit breaker charging motor and auxiliary contacts

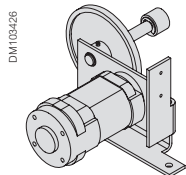
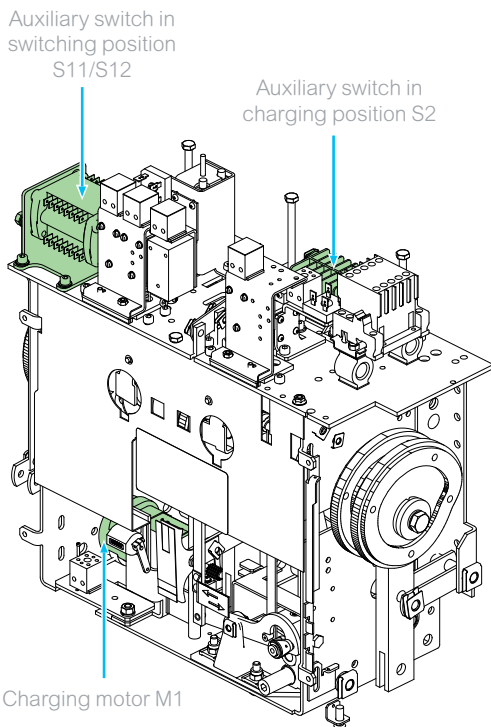

Charging motor M1

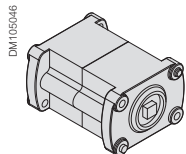

Auxiliary switch in switching position S11/S12

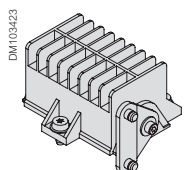

Auxiliary switch in charging position S2

## Operating mechanism

### Charging motor M1

The electric motor charges the spring of the operating mechanism automatically as soon as it is discharged. This allows the circuit breaker to switch the second close-open-cycle within the rated operating sequence.

#### Characteristics

Power supply	V a.c.	110/220/230
	V d.c.	24*/48/60/110/125/220
Operating range	V a.c.	0.85 to 1.1 Ua
	V d.c.	0.85 to 1.1 Ua
Consumption	V a.c.	approx. 100 VA
	V d.c.	approx. 100 W

\* Please contact Schneider Electric

#### Operating time of motor

Motor charging time	4 ~ 12s
---------------------	---------

### “Open/closed” auxiliary contacts

The number of contacts available depends on the options chosen on the operating mechanism.

In the basic configuration, the circuit breaker’s operating mechanism comprises a total of:

- 8 normally closed (NC) contacts; some contacts are already used, free contacts as per wiring diagram
- 8 normally open (NO) contacts; some contacts are already used, free contacts as per wiring diagram

### Auxiliary switch in switching position S11/S12

The auxiliary contacts in switching position indicate the ON/OFF status of the circuit breaker. They are actuated directly by the main shaft of the circuit breaker via a mechanical link. The position of the main shaft corresponds to the position of the auxiliary switches and indicates whether the breaker is in ON or OFF.

#### Characteristics

Rated operational voltage (Ue)	V a.c./ d.c.	230			
Rated operational current (Ic)	A	15			
Rated short-time withstand current (Icw)	A	250 (during 3s)			
Rated breaking capacity with inductive charge	L/R=10 ms	L/R=20 ms			
Voltage	V d.c.	48	125	125	220
Charging current	A	10	3,8	2	1

### Auxiliary switch in charging position S2

The auxiliary switch is used to control the charging motor and to indicate the charging status..

When contact S2 is closed, the motor is charging the spring of the operating mechanism automatically. When charging is complete, it breaks the electrical charging circuit.

For technical datas of S2 please refer to the table in S11/S12.

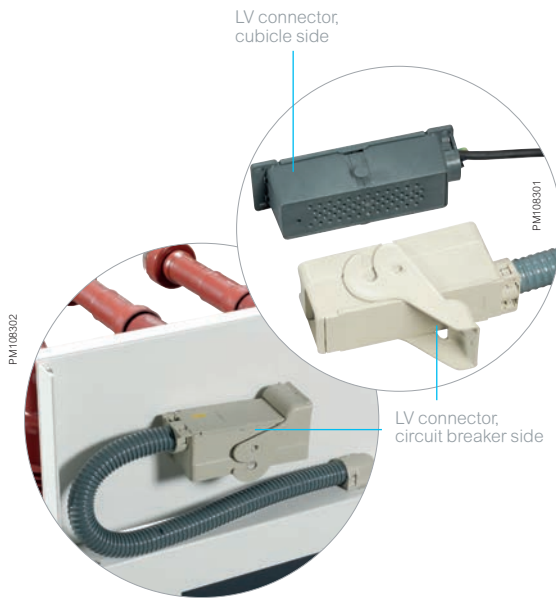

## Withdrawable type

An optional flexible LV (Low Voltage) plug and socket system enables connection of the circuit breaker auxiliary circuits to the switchgear control cabinet. It consists of an elbow-type connector mounted on the frame of the circuit breaker and a removable connector with 58 male pins mounted on a 525 mm flexible duct. This LV connector is to be connected to the LV cabinet of the cubicle.

The counter part connector equipped with the female contacts is assembled in the low voltage cabinet of the switchgear.

The LV plug collects electrical commands and status information from the circuit breaker terminal blocks and from the racking trolley terminal blocks. The number of pins in the LV plug (maximum 58) may limit the number of available position contacts for the switchgear LV cabinet.

The EvoPact HVX LV connector can only be removed when the circuit breaker is at the test position.



## Fixed type

The breaker is equipped with a set of terminal blocks or with a LV plug to connect the circuit breaker auxiliary circuit with the LV wiring from the LV cabinet.



# Racking trolley

PM108288



Racking trolley

## Withdrawable type

In the withdrawable type the EvoPact HVX is mounted on a racking trolley to move the circuit breaker between test position and service position .

The EvoPact HVX racking trolley comprises:

- A frame with 4 wheels for moving the circuit breaker
- A drive system with a rotating shaft to move the circuit breaker inside the switchgear compartment
- An optional motor drive for electrical operation (A motor controller is provided and attached to the circuit breaker. It is mandatory for the trolley motorization function).
- A set of auxiliary contacts (3NC+3NO available for customer use), to indicate the service or test position of the circuit breaker
- A set of mechanical levers to interlock the trolley with the operating mechanism and the earthing switch operation if assembled in the switchboard
- A system to latch the racking trolley to the switchgear frame to withstand the mechanical forces of the short circuit
- An interlock between the racking trolley and the door of the panel

The circuit breaker is equipped with devices to operate the shutter mechanism.

## Earthing

The racking trolley is earthed using underneath copper bars located under the racking trolley.

For 12 kV and 17.5 kV, this can also be equipped with earthing sliding contacts on both sides of the racking trolley.

DM105018

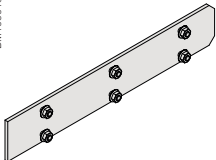

Underneath earthing

DM105019

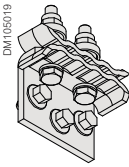

Side earthing

## EvoPact HVX withdrawable type interlocking

The following table describes the interlocking functions available on the withdrawable type of EvoPact HVX.

### How to use the table

Each box describes the possible status of parts interlocked with the circuit breaker at a given status.

- **Removed:** The circuit breaker with the racking trolley is extracted from the switchgear with the racking trolley
- **Disconnected:** The circuit breaker is inside the switchgear compartment; its power connections are separated from the switchgear contacts by shutters and the LV auxiliary circuits are connected
- **Intermediate:** The circuit breaker is moving from the disconnected position to the service position or vice versa
- **Service:** The circuit breaker power connections are connected to the switchgear contacts, the LV auxiliary circuits are connected, and the switchgear door is closed and locked

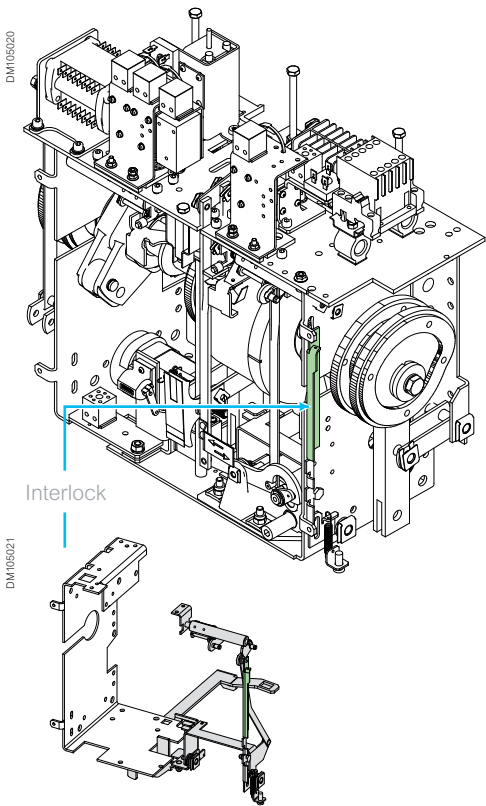

### Circuit breaker status

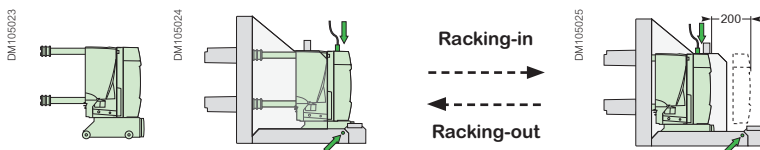

Parts		Removed	Disconnected	Intermediate	Service
Compartment shutters	Open	<b>Prohibited</b>	Not possible	Operating	Mandatory
	Closed	Mandatory	Mandatory		Not possible
Switchgear door	Open	Possible	Possible (1)	<b>Prohibited</b>	<b>Prohibited</b>
	Closed	Possible	Preferred	Mandatory (2)	Mandatory
Door handle		Unlocked	Unlocked	Locked (2)	Locked (2)
LV connector	Disconnected	Mandatory	Possible (1)	<b>Prohibited</b>	Prohibited
	Connected	Not possible	Preferred	Mandatory (3)	Mandatory (3)
CB operating mechanism	Open	Possible	Preferred	Mandatory	Possible
	Closed	Possible	Possible	<b>Prohibited</b> (4)	Possible (5)
Earthing switch position	Open	Possible	Possible	Mandatory	Mandatory
	Closed	Possible	Possible (1)	<b>Prohibited</b>	<b>Prohibited</b>

(1) Impossible to rack-in

(2) Impossible to access the CB compartment

(3) Impossible to access the LV plug

(4) Impossible to activate the "close" command

(5) Impossible to rack-out

## Specific interlocking

This is a mechanical device, which allows the panel builders to create their own interlock. Fixed type circuit breakers, which are converted into a withdrawable circuit breaker by the customer using the customer's own racking trolley, need to have an interlock between the circuit breaker and the trolley.

This interlock helps to realize below functions:

- It is not possible to close the circuit breaker during racking in/out.
- It is not possible to do the racking in/out when the circuit breaker is closed.

Please refer to user guide NVE8601501 for detailed instruction

Note: This part is installed during the manufacturing process for the fixed type circuit breaker.

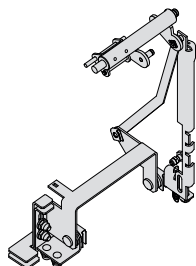

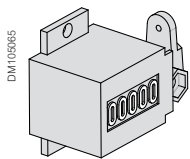
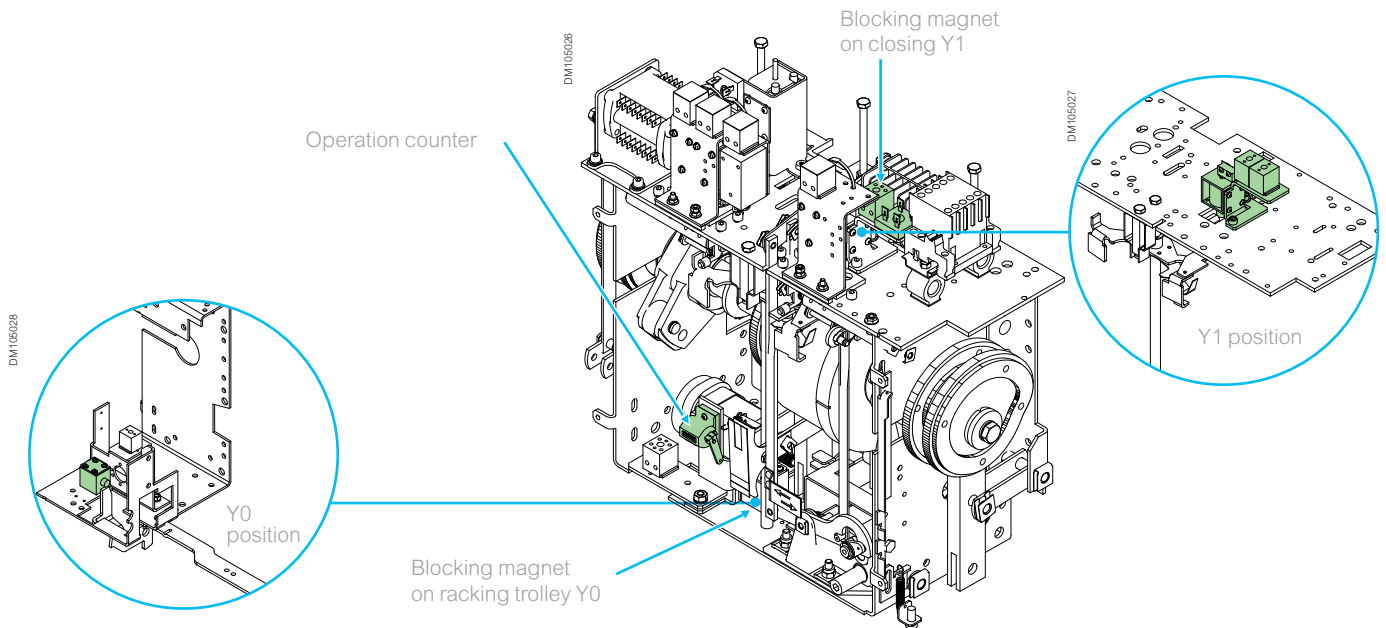

Operation counter

## Operation counter

The operation counter installed on the operating mechanism records the number of opening/closing cycles.

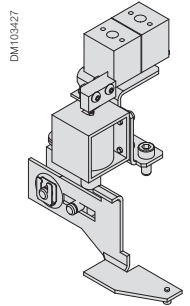

Blocking magnet on closing Y1

## Blocking magnet

### Blocking magnet on closing Y1

If the controlling power supply to operate this magnet is lost, the circuit breaker cannot perform the normal closing operation (including manual closing).

### Blocking magnet on racking trolley Y0

If the secondary controlling power supply is lost, the trolley cannot be racked in or out (either manually or by motorization).

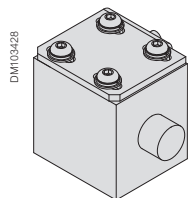

Blocking magnet on racking trolley Y0

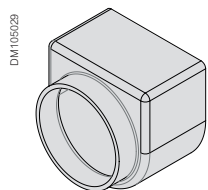

Insulating sleeves for breaker

## Insulating sleeves for breaker

For fixed type breakers that are converted to withdrawable types, insulating sleeves can be ordered to improve the dielectric withstand at the contact point.

# Secondary wiring diagrams

## EvoPact HVX withdrawable type with anti-pumping device

DW105030

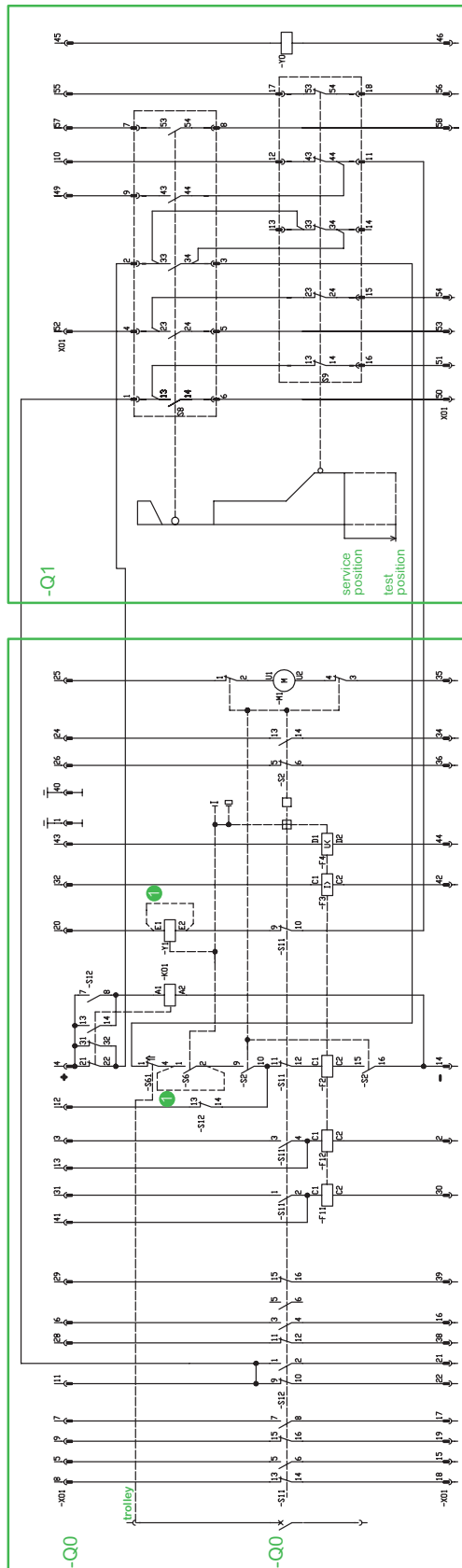

Drawing number: ASX000525-01

1. This circuit diagram shows the maximum circuit breaker equipment. The standard equipment does not include optional items. If optional items are required, these should be stated when placing the order.
2. Circuit breaker is in discharge and open position, racking trolley is in service position.
3. If circuit breaker is without blocking magnet for closing Y1, refer to  in the wiring diagram (no Y1, no S6)

<b>-Q0</b>	<b>Units incorporated in the circuit breaker according to the order</b>	<b>-Q1</b>	<b>Units incorporated in the switchgear trolley according to the order</b>
-M1	Motor for operating mechanism	-S8	Test position switch
-S11/12	Auxiliary switch position indicator	-S9	Service position switch
-S2	Micro switch for motor control	-Y0	Blocking magnet for trolley (optional)
-S6	Micro switch for blocking magnet		
-Y1	Blocking magnet for closing (optional)		
-F11	Opening release		
-F12	Opening release (optional)		
-F2	Closing release		
-F3	Overcurrent release (optional)		
-F4	Undervoltage release (optional)		
-K01	Anti-pumping relay		
-S61	Micro switch actuated by trolley operation or trolley not in end position		

# Secondary wiring diagrams

EvoPact HVX withdrawable type without anti-pumping device

DW109031

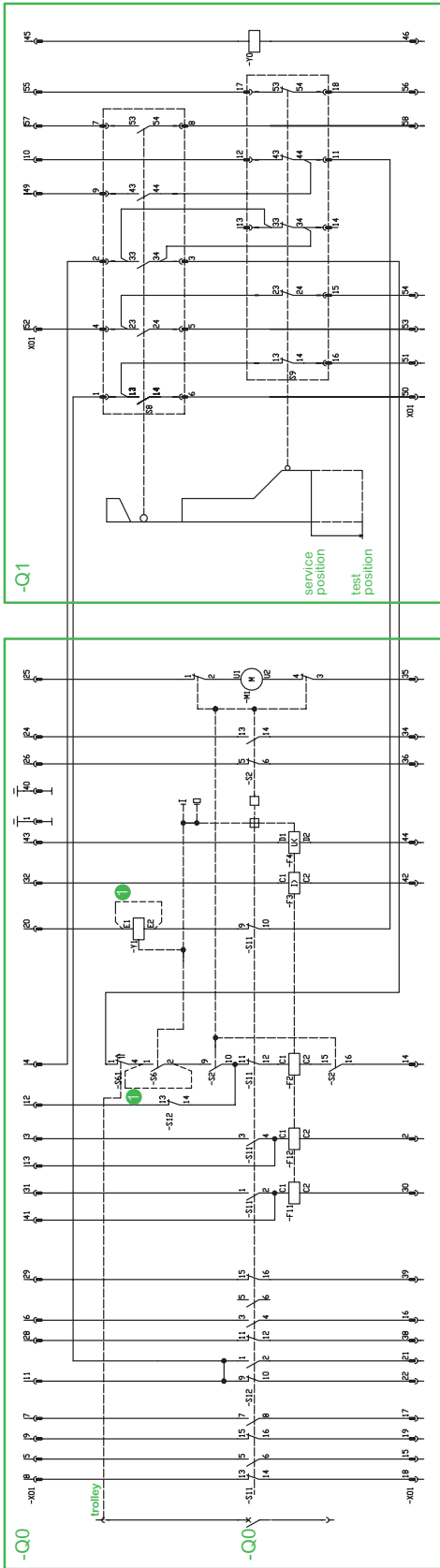

Drawing number: ASX000525-02

1. This circuit diagram shows the maximum circuit breaker equipment. The standard equipment does not include optional items. If optional items are required, these should be stated when placing the order.
2. Circuit breaker is in discharge and open position, racking trolley is in service position.
3. If circuit breaker is without blocking magnet for closing Y1, refer to 1 in the wiring diagram (no Y1, no S6)

**-Q0** Units incorporated in the circuit breaker according to the order

- M1 Motor for operating mechanism
- S11/12 Auxiliary switch position indicator
- S2 Micro switch for motor control
- S6 Micro switch for blocking magnet
- Y1 Blocking magnet for closing (optional)
- F11 Opening release
- F12 Opening release (optional)
- F2 Closing release
- F3 Overcurrent release (optional)
- F4 Undervoltage release (optional)
- K01 Anti-pumping relay
- S61 Micro switch actuated by trolley operation or trolley not in end position

**-Q1** Units incorporated in the switchgear trolley according to the order

- S8 Test position switch
- S9 Service position switch
- Y0 Blocking magnet for trolley (optional)





# Secondary wiring diagrams

## EvoPact HVX fixed type without anti-pumping device

DW105033

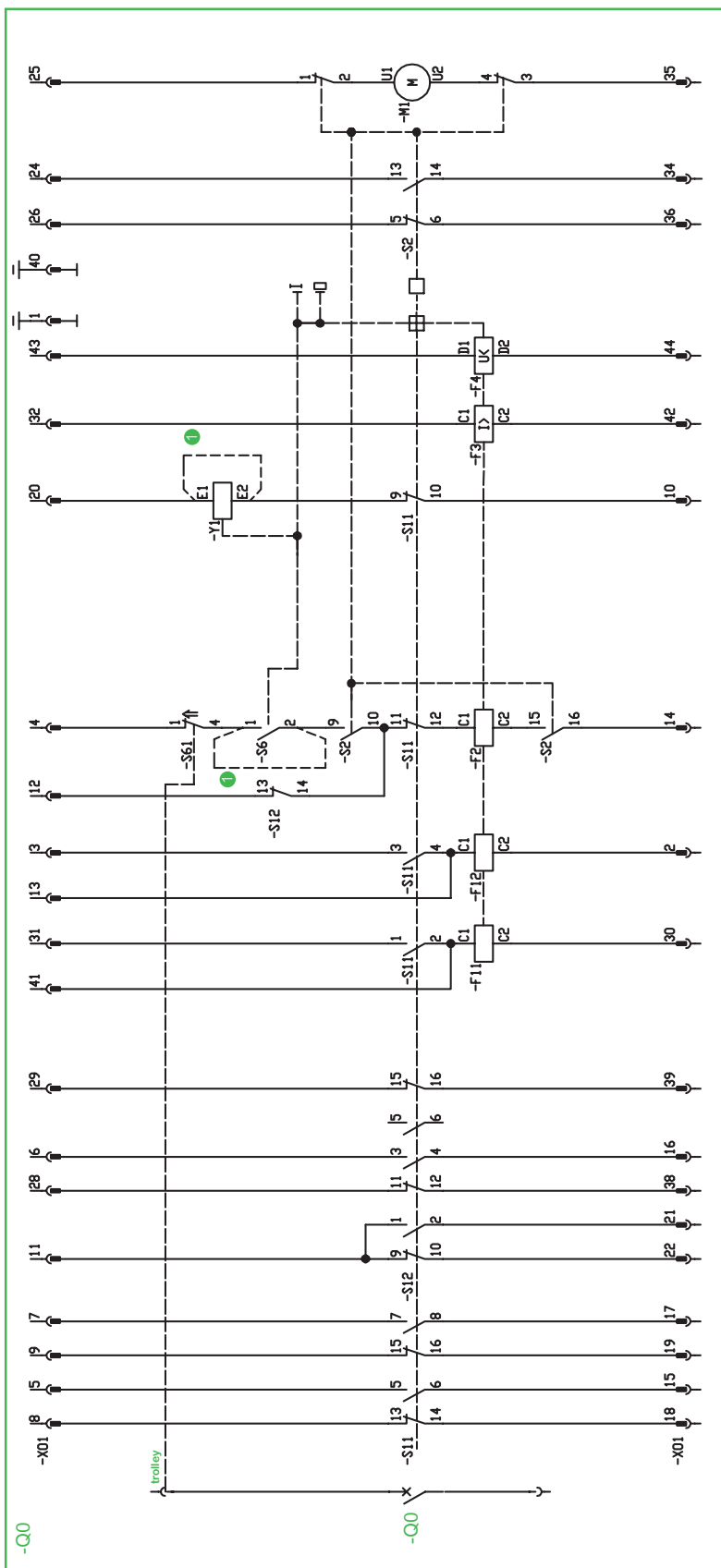

Drawing number: ASX000525-04

1. This circuit diagram shows the maximum circuit breaker equipment. The standard equipment does not include optional items. If optional items are required, these should be stated when placing the order.
2. Circuit breaker is in discharge and open position, racking trolley is in service position.
3. If circuit breaker is without blocking magnet for closing Y1, refer to 1 in the wiring diagram (no Y1, no S6)

### -Q0 Units incorporated in the circuit breaker according to the order

- M1 Motor for operating mechanism
- S11/12 Auxiliary switch position indicator
- S2 Micro switch for motor control
- S6 Micro switch for blocking magnet
- Y1 Blocking magnet for closing (optional)
- F11 Opening release
- F12 Opening release (optional)
- F2 Closing release
- F3 Overcurrent release (optional)
- F4 Undervoltage release (optional)
- K01 Anti-pumping relay
- S61 Micro switch actuated by operation

# Secondary wiring diagrams

EvoPact HVX motorized trolley withdrawable type with anti-pumping device

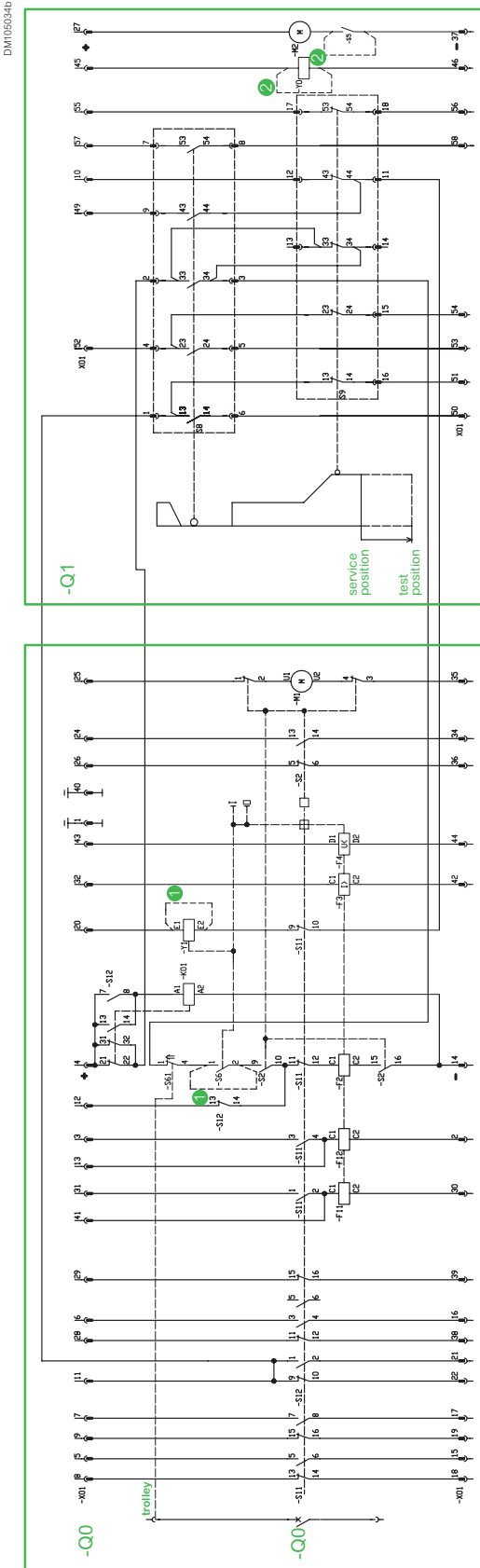

Drawing number: ASX000525-05

1. This circuit diagram shows the maximum circuit breaker equipment. The standard equipment does not include optional items. If optional items are required, these should be stated when placing the order.
2. Circuit breaker is in discharge and open position, racking trolley is in service position.
3. If circuit breaker is without blocking magnet for closing Y1, refer to ❶ in the wiring diagram (no Y1, no S6)
4. If circuit breaker is without blocking magnet for trolley Y0, refer to ❷ in the wiring diagram (no Y0, no S3)

**-Q0 Units incorporated in the circuit breaker according to the order**

- M1 Motor for operating mechanism
- S11/12 Auxiliary switch position indicator
- S2 Micro switch for motor control
- S6 Micro switch for blocking magnet
- Y1 Blocking magnet for closing (optional)
- F11 Opening release
- F12 Opening release (optional)
- F2 Closing release
- F3 Overcurrent release (optional)
- F4 Undervoltage release (optional)
- K01 Anti-pumping relay
- S61 Micro switch actuated by trolley operation or trolley not in end position

**-Q1 Units incorporated in the switchgear trolley according to the order**

- S8 Test position switch
- S9 Service position switch
- Y0 Blocking magnet for trolley (optional)
- M2 Motor for racking trolley
- S5 Y0 auxiliary contact

# Secondary wiring diagrams

EvoPact HVX motorized trolley withdrawable type without anti-pumping device

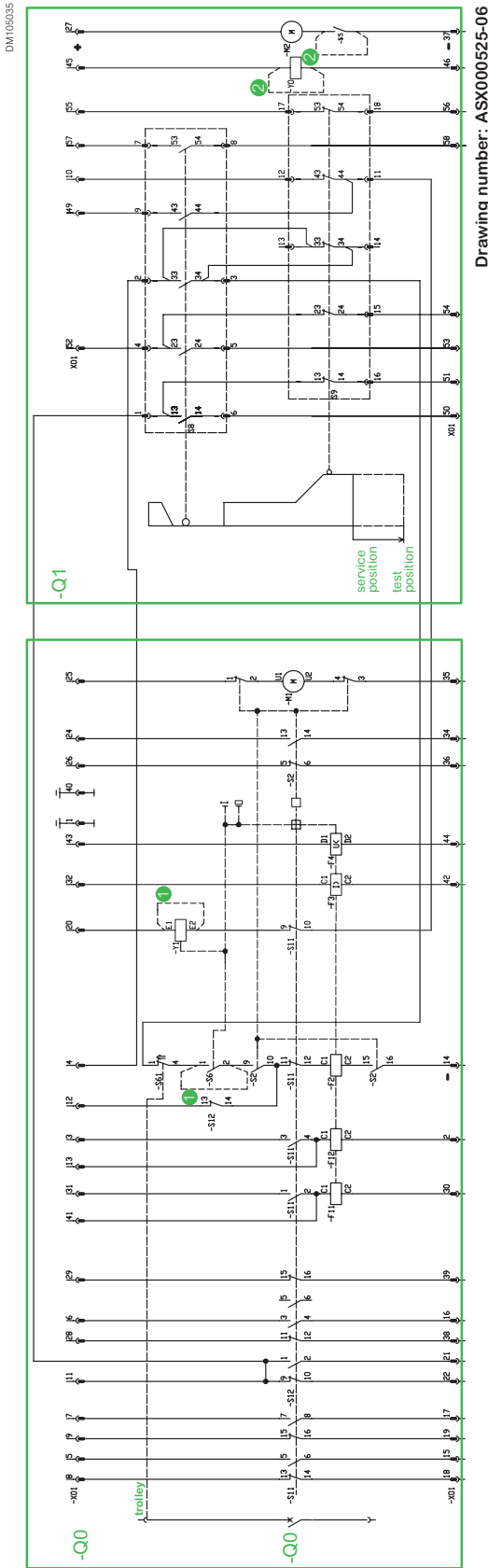

Drawing number: ASX000525-06

1. This circuit diagram shows the maximum circuit breaker equipment. The standard equipment does not include optional items. If optional items are required, these should be stated when placing the order.

2. Circuit breaker is in discharge and open position, racking trolley is in service position.

3. If circuit breaker is without blocking magnet for closing Y1, refer to ❶ in the wiring diagram (no Y1, no S6)

4. If circuit breaker is without blocking magnet for trolley Y0, refer to ❷ in the wiring diagram (no Y0, no S3)

- |            |   |            |  |
|------------|---|------------|--|
| <b>-Q0</b> | <b>Units incorporated in the circuit breaker according to the order</b>   | <b>-Q1</b> | <b>Units incorporated in the switchgear trolley according to the order</b> |
| M1         | Motor for operating mechanism   | S8         | Test position switch   |
| S11/12     | Auxiliary switch position indicator                                       | S9         | Service position switch  |
| S2         | Micro switch for motor control  | Y0         | Blocking magnet for trolley (optional)                                     |
| S6         | Micro switch for blocking magnet  | M2         | Motor for racking trolley  |
| Y1         | Blocking magnet for closing (optional)                                    | S5         | Y0 auxiliary contact   |
| F11        | Opening release   |            |  |
| F12        | Opening release (optional)  |            |  |
| F2         | Closing release   |            |  |
| F3         | Overcurrent release (optional)  |            |  |
| F4         | Undervoltage release (optional)   |            |  |
| K01        | Anti-pumping relay  |            |  |
| S61        | Micro switch actuated by trolley operation or trolley not in end position |            |  |

Notes

---

# Dimensions

# Dimensions

EvoPact HVX 12 kV withdrawable type	46
EvoPact HVX 12/17.5 kV fixed type	48
EvoPact HVX 17.5 kV withdrawable type	50
EvoPact HVX 24 kV withdrawable type	52
EvoPact HVX 24 kV fixed type	54



# EvoPact HVX 12 kV withdrawable type

## Dimension drawing

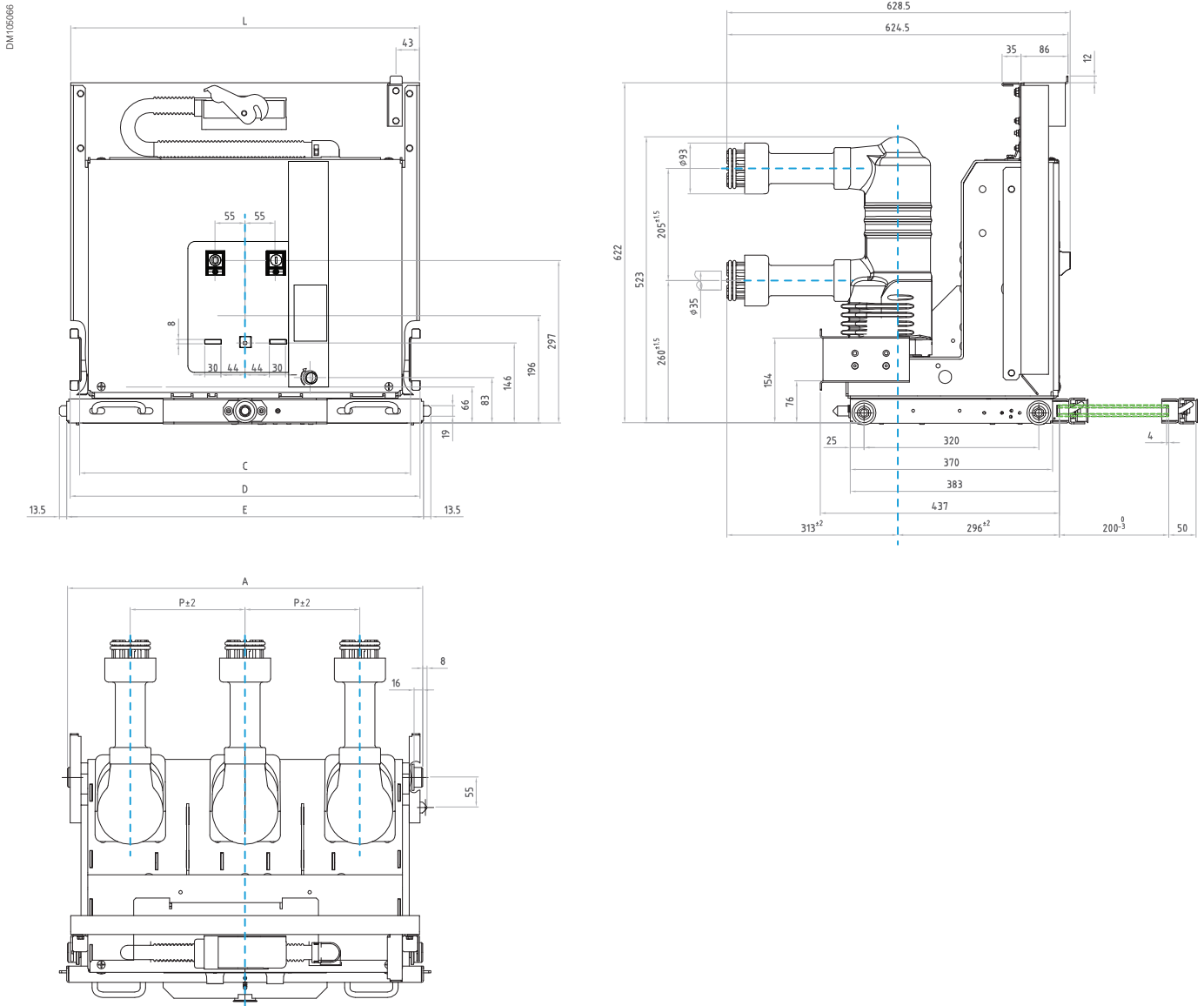

### EvoPact HVX 12 vacuum circuit breaker

Rated voltage (kV)	12
Rated short-circuit current (kA)	25; 31.5
Rated current (A)	630; 1,250

Rated current (A)		Rated short-circuit current (kA)		Installation dimensions (mm)					
				P	A	C	D	E	L
630	1,250	25	31.5	150	502	457	492	503	494
				210	650	605	640	653	638
				275	850	801	836	853	844

# EvoPact HVX 12 kV withdrawable type

## Dimension drawing

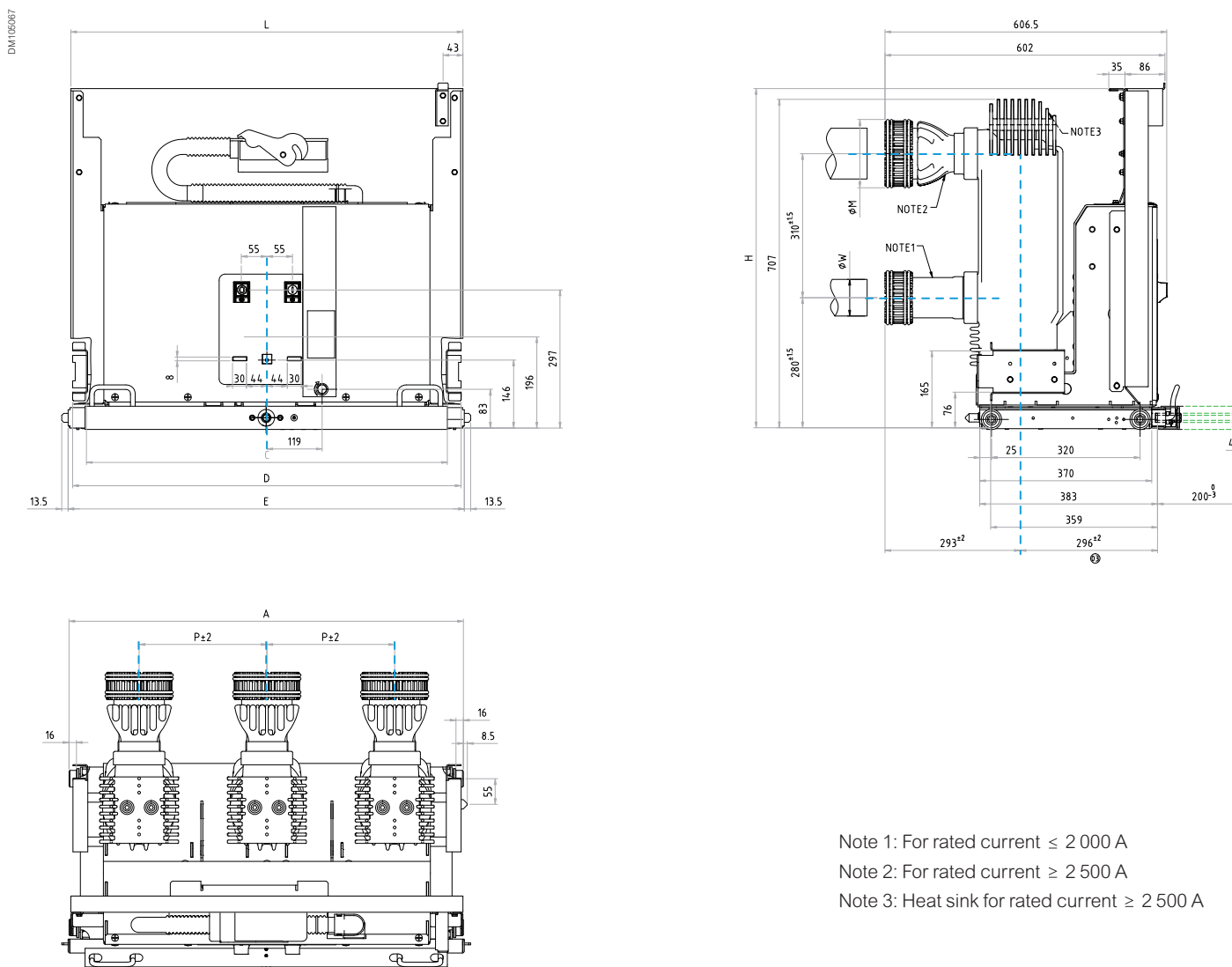

Note 1: For rated current  $\leq 2\,000$  A  
 Note 2: For rated current  $\geq 2\,500$  A  
 Note 3: Heat sink for rated current  $\geq 2\,500$  A

Rated current (A)		Rated short-circuit current (kA)		Installation dimensions (mm)										
P	A	C	D	E	L	H	$\varnothing M$	$\varnothing W$						
1,600	2,000	25	31.5	210	650	582	640	653	638	691.5	118	79		
1,250	1,600	2,000	40	275	850	777	836	853	844	729.5	118	79		
1,250	1,600	2,000	50	210	650	582	640	653	638	691.5	128	79		
				275	850	777	836	853	844	729.5	128	79		
2,500	3,150	4,000 (1)	25	31.5	40	275	850	777	836	853	844	729.5	148	109
			50			275	850	777	836	853	844	729.5	158	109

(1) The rated current 4,000 A requires forced cooling in the panel.

# EvoPact HVX 12/17.5 kV fixed type

## Dimension drawing

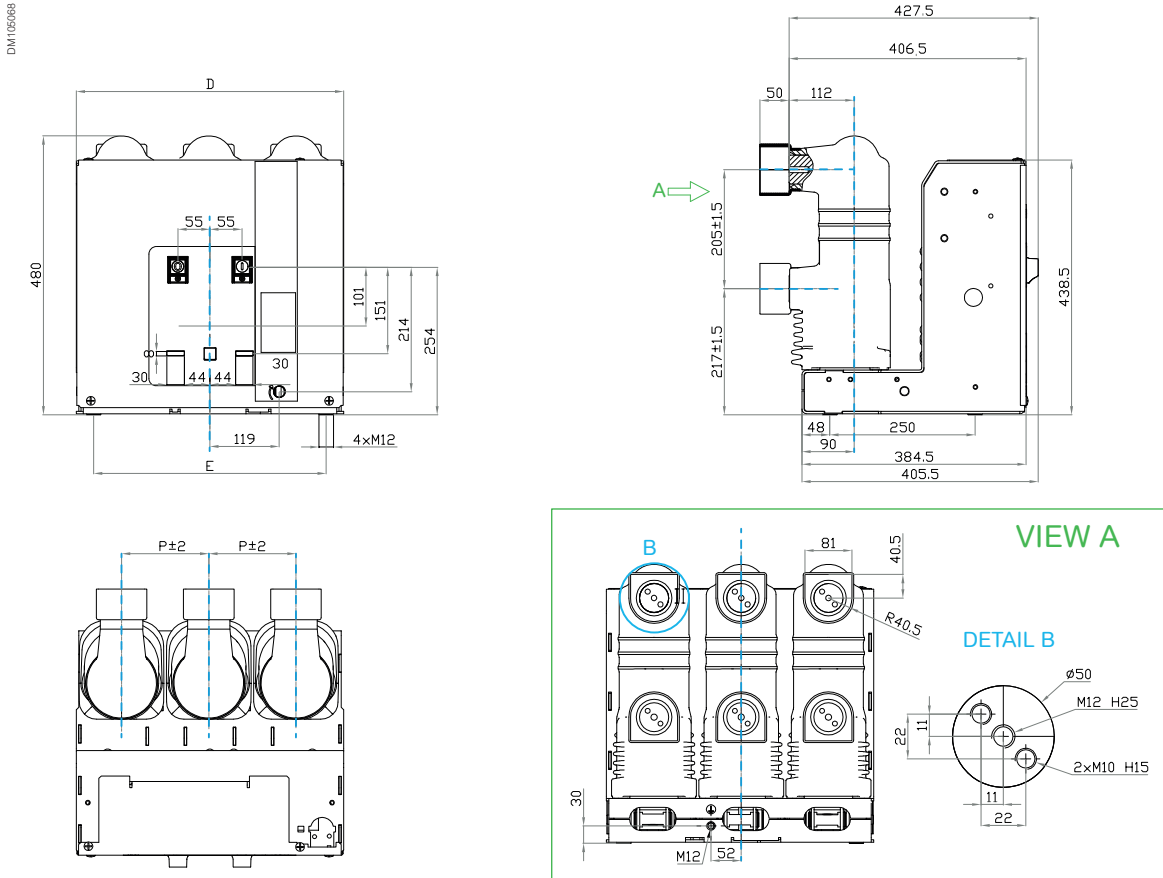

### EvoPact HVX vacuum circuit breaker

Rated voltage (kV)	12; 17.5
Rated short-circuit current (kA)	25; 31.5
Rated current (A)	630; 1,250

Rated current (A)		Rated short-circuit current (kA)		Installation dimensions (mm)		
				P	D	E
630	1,250	25	31.5	150	460	400
				210	576	520
				275	706	650

# EvoPact HVX 12/17.5 kV fixed type

## Dimension drawing

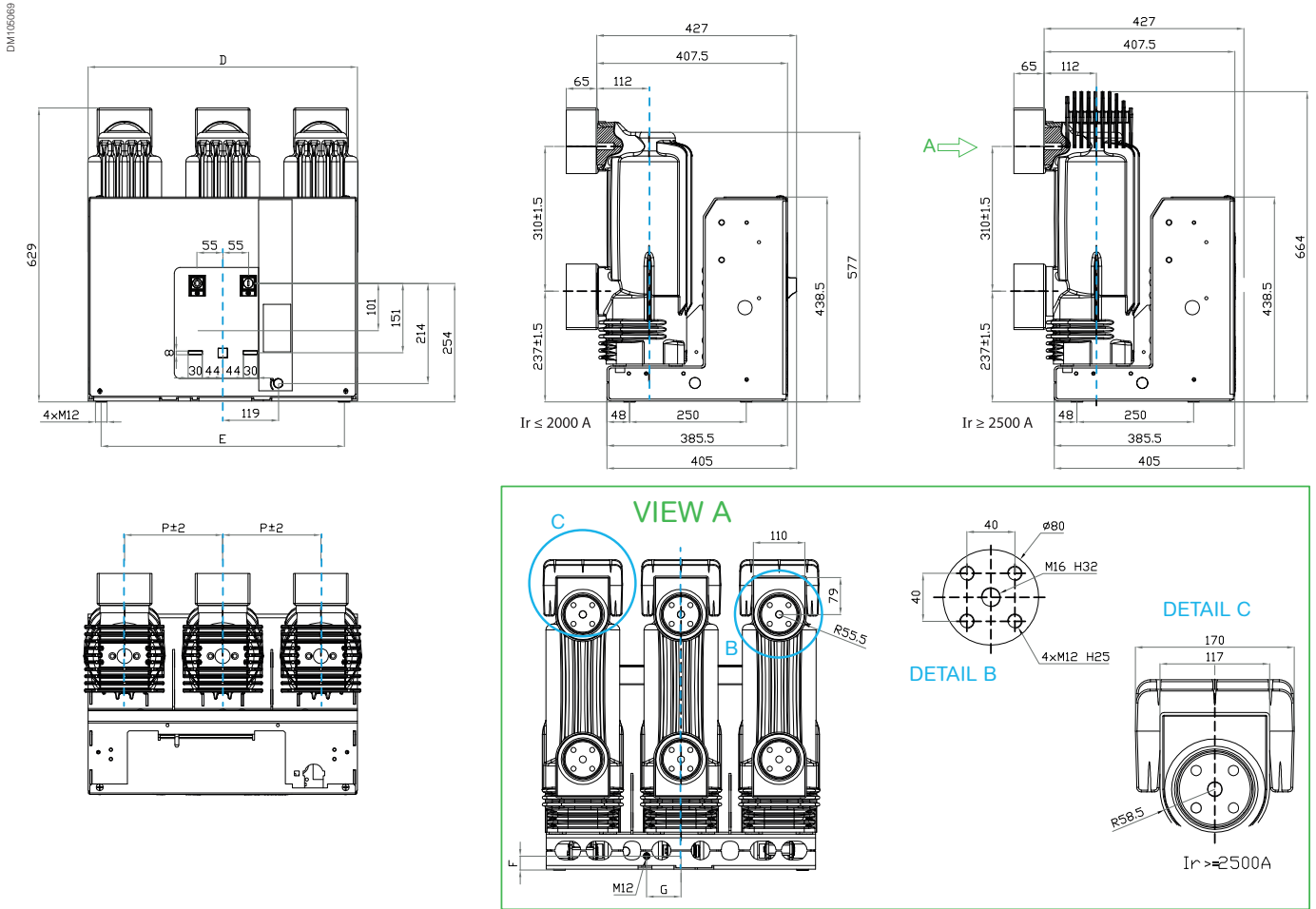

### EvoPact HVX vacuum circuit breaker

Rated voltage (kV)	12; 17.5
Rated short-circuit current (kA)	25; 31.5; 40; 50
Rated current (Ir) (A)	1,250; 1,600; 2,000; 2,500; 3,150; 4,000 <sup>(1)</sup>

Rated current (A)	Rated short-circuit current (kA)		Installation dimensions (mm)				
			P	D	E	F	G
1,250	40	50	210	576	520	30	0
1,600    2,000	25	31.5    40    50	275	704	650	26	137.5
2,500    3,150    4,000 <sup>(1)</sup>	25	31.5    40    50	275	704	650	26	137.5

<sup>(1)</sup> The rated current 4,000 A requires forced cooling in the panel.

# EvoPact HVX 17.5 kV withdrawable type

## Dimension drawing

DW106070

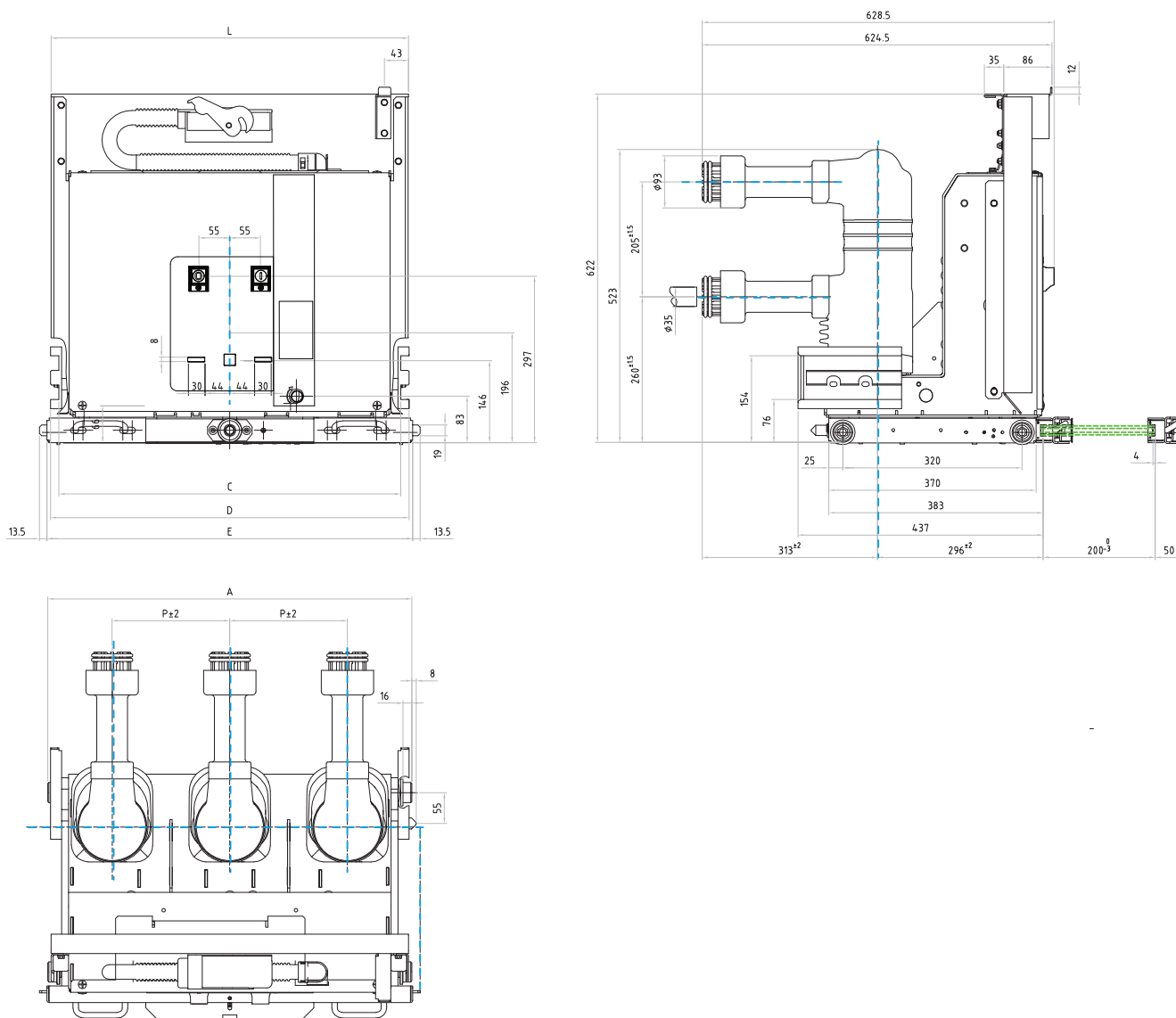

### EvoPact HVX vacuum circuit breaker

Rated voltage (kV)	17.5
Rated short-circuit current (kA)	25; 31.5
Rated current (A)	630; 1,250

Rated current (A)		Rated short-circuit current (kA)		Installation dimensions (mm)					
				P	A	C	D	E	L
630	1,250	25	31.5	150	502	462	492	503	494
				210	650	610	640	653	638
				275	850	806	836	853	844

# EvoPact HVX 17.5 kV withdrawable type

## Dimension drawing

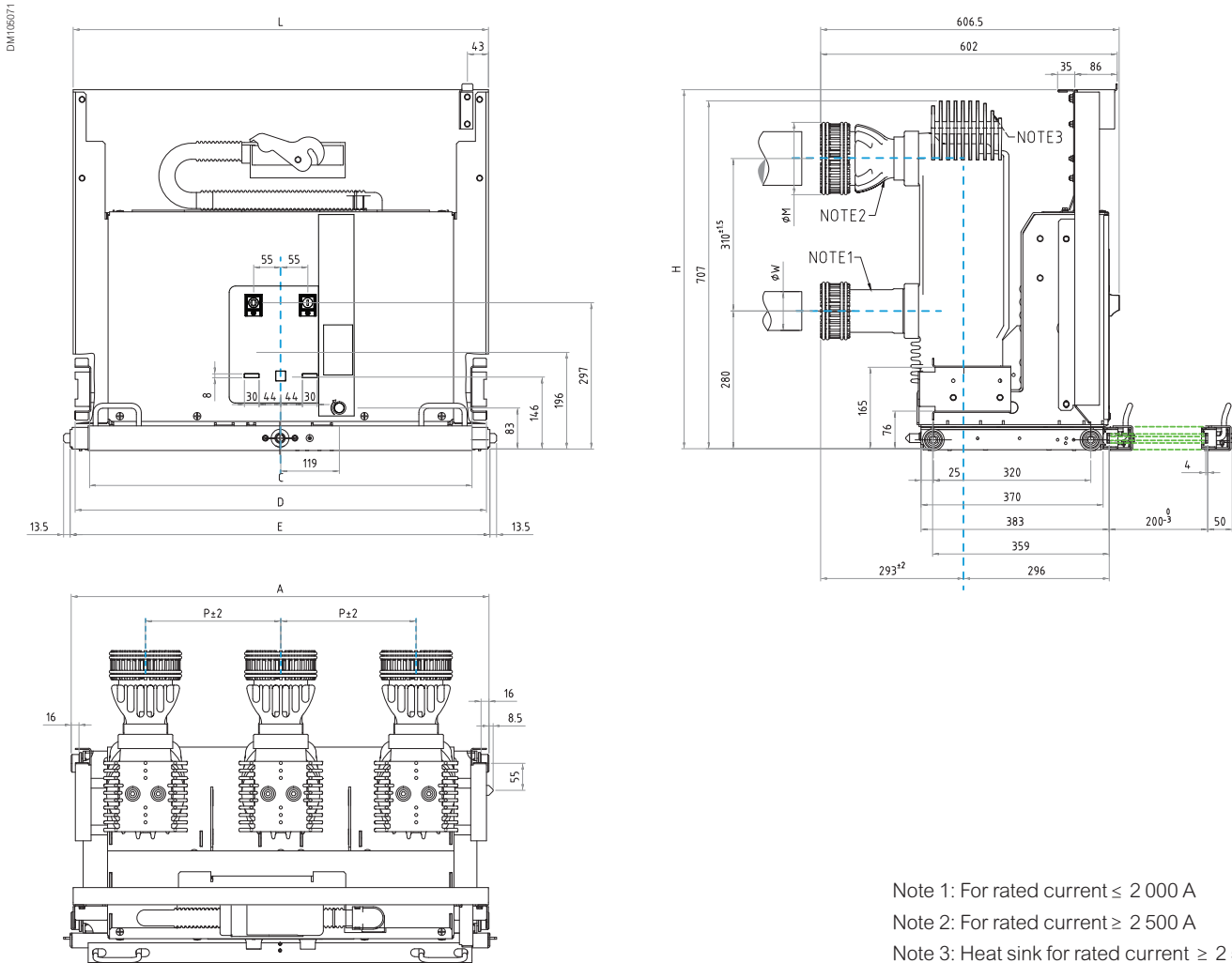

- Note 1: For rated current  $\leq 2\,000\text{ A}$
- Note 2: For rated current  $\geq 2\,500\text{ A}$
- Note 3: Heat sink for rated current  $\geq 2\,500\text{ A}$

Rated current (A)		Rated short-circuit current (kA)		Installation dimensions (mm)										
P	A	C	D	E	L	H	Ø M	Ø W						
1,600	2,000	25	31.5	210	650	582	640	653	638	691.5	118	79		
1,250	1,600	2,000	40	275	850	777	836	853	844	729.5	118	79		
1,250	1,600	2,000	50	210	650	582	640	653	638	691.5	128	79		
				275	850	777	836	853	844	729.5	128	79		
2,500	3,150	4,000 <sup>(1)</sup>	25	31.5	40	275	850	777	836	853	844	729.5	148	109
2,500	3,150	4,000 <sup>(1)</sup>	50			275	850	777	836	853	844	729.5	158	109

(1) The rated current 4,000 A requires forced cooling in the panel



# EvoPact HVX 24 kV withdrawable type

## Dimension drawing

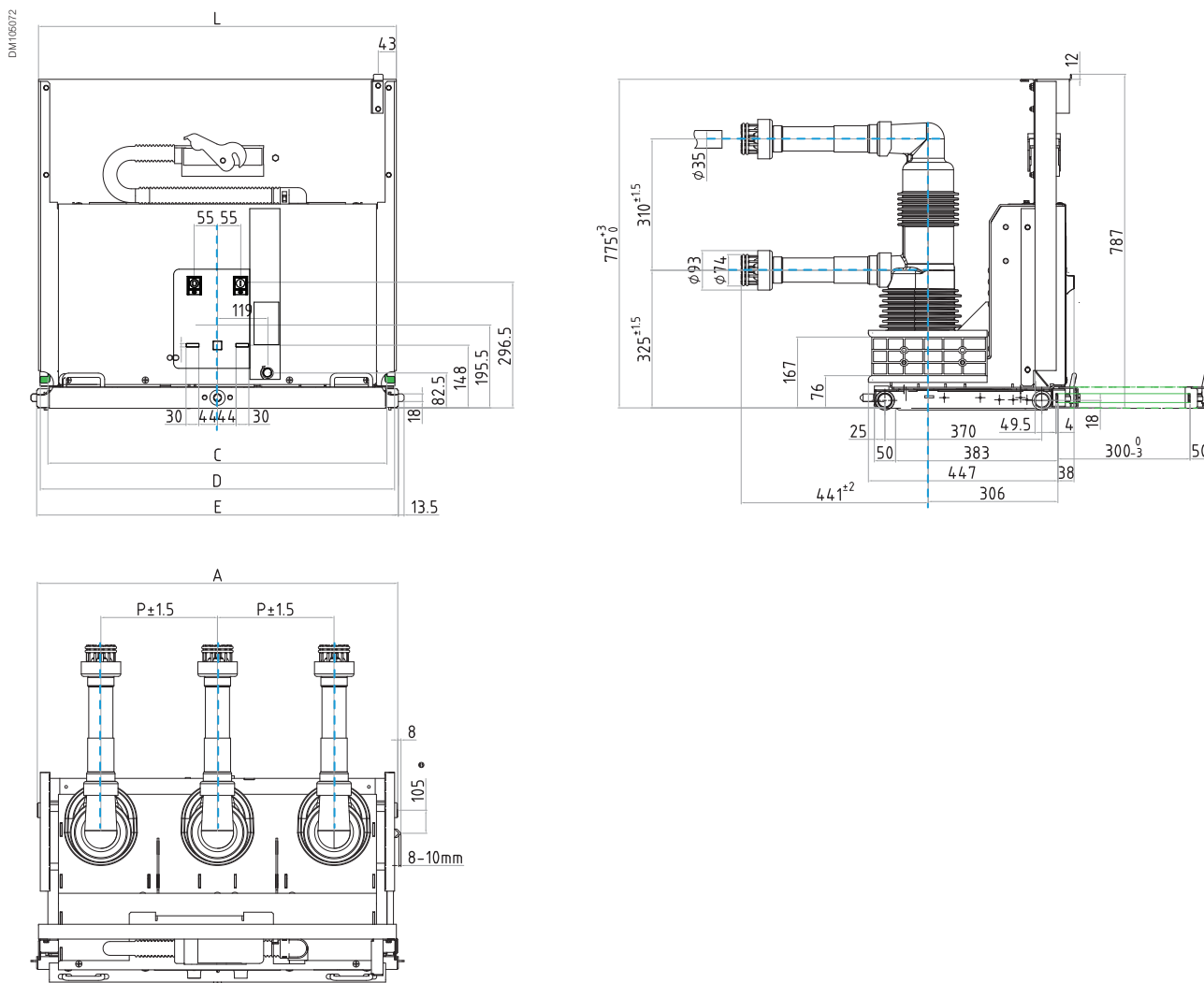

### EvoPact HVX vacuum circuit breaker

Rated voltage (kV)	24
Rated short-circuit current (kA)	25
Rated current (A)	630; 1,250

Rated current (A)		Rated short-circuit current (kA)	Installation dimensions (mm)					
			P	A	C	D	E	L
630	1,250	25	210	650	612	646	653	648
			275	850	802	836	853	844

# EvoPact HVX 24 kV withdrawable type

## Dimension drawing

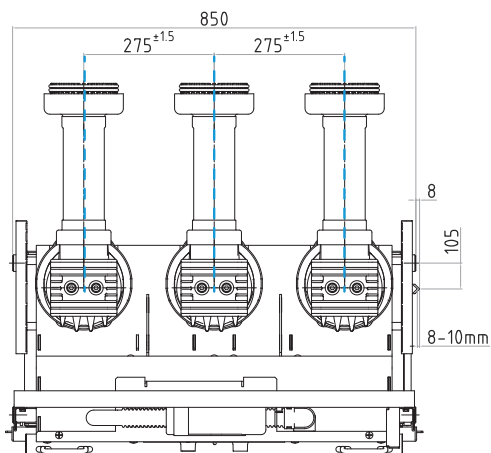
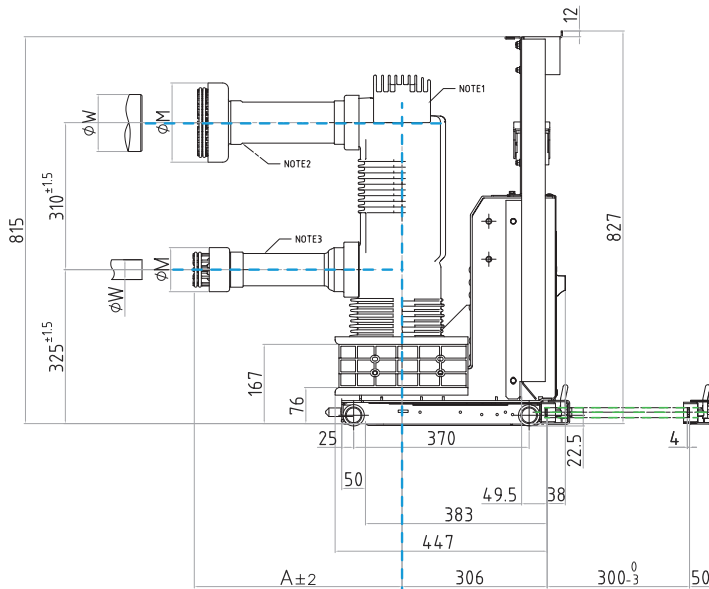
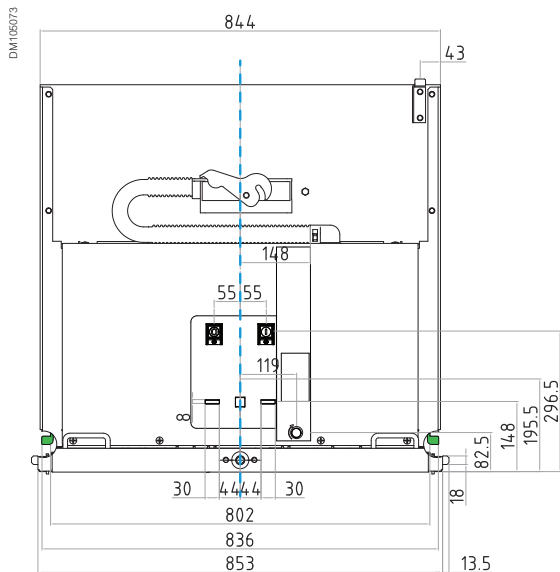

- Note 1: Heat sink for rated current = 2 500 A
- Note 2: For rated current ≥ 1 600 A
- Note 3: For rated current ≤ 1 250 A

### EvoPact HVX vacuum circuit breaker

Rated voltage (kV)	24
Rated short-circuit current (kA)	25; 31.5
Rated current (A)	1,600; 2,000; 2,500

Rated current (A)	Rated short-circuit current (kA)	Installation dimensions (mm)		
		Ø M	Ø W	A
1,600 2,000 2,500	25 31.5	135	79	431
630 1250	31.5	93	35	441

# EvoPact HVX 24 kV fixed type

## Dimension drawing

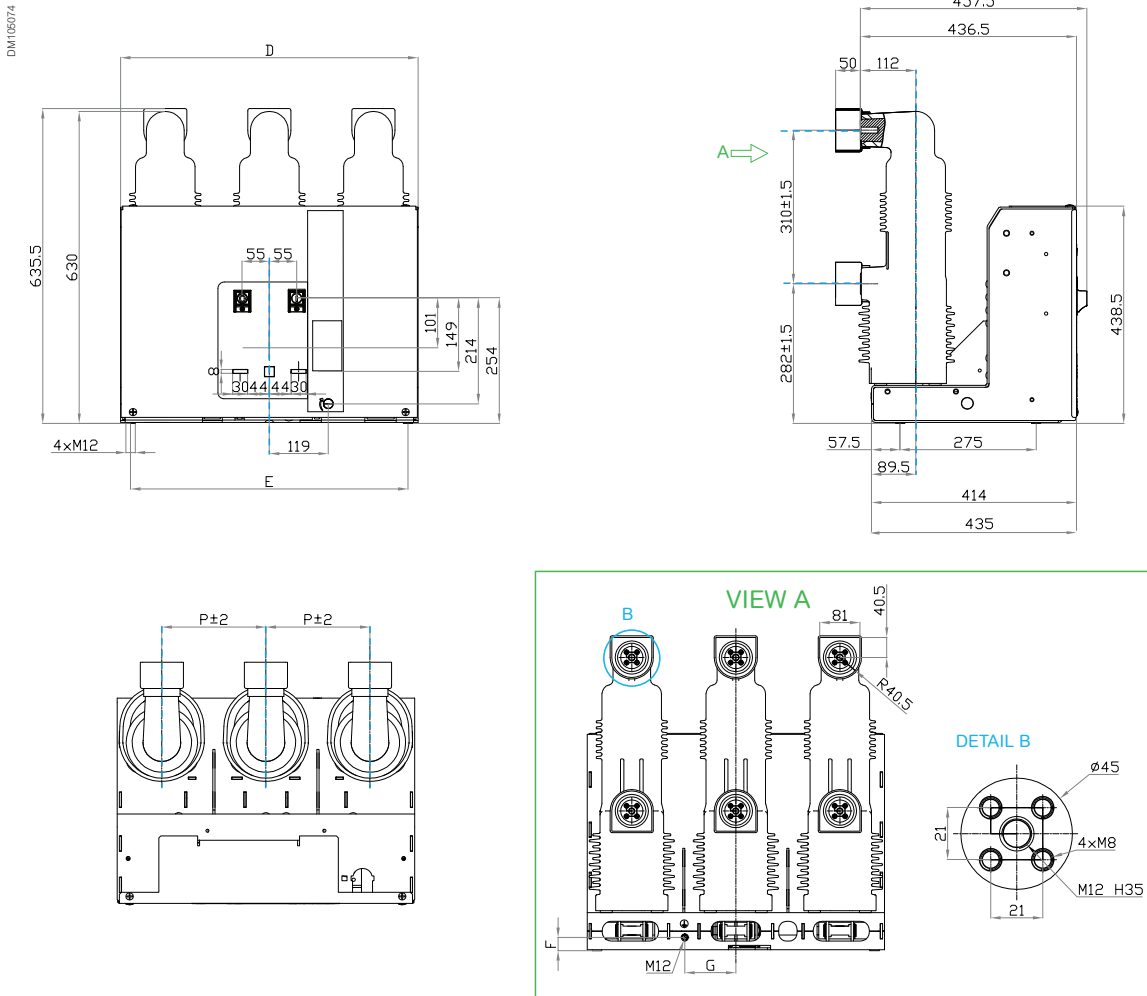

Rated current (A)		Rated short-circuit current (kA)	Installation dimensions (mm)				
630	1,250		P	D	E	F	G
630	1,250	25	210	600	560	27	103
			275	756	700	26	137.5

# EvoPact HVX 24 kV fixed type

## Dimension drawing

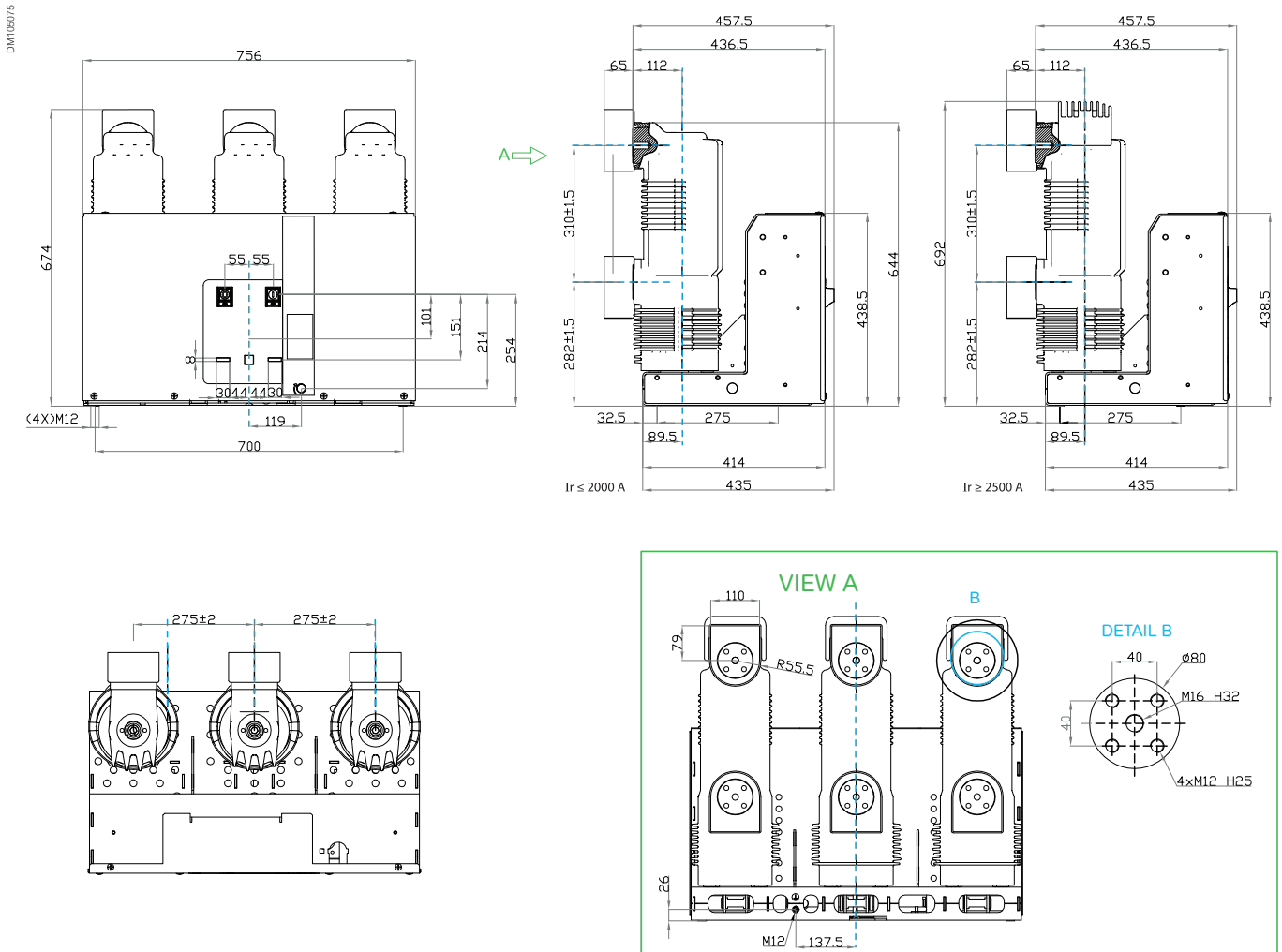

### EvoPact HVX vacuum circuit breaker

Rated voltage (kV)	Rated current (A)	Rated short-circuit current (kA)
24	1,600; 2,000; 2,500	25
	630; 1,250; 1,600; 2,000; 2,500	31.5

# Product references

# Product references

---

<b>EvoPact HVX 12 kV/17.5 kV/24 kV order form</b>	<b>58</b>
Basic equipment	58
Options and accessories	59

---

<b>Spare parts</b>	<b>60</b>
--------------------	-----------

---



# EvoPact HVX 12 kV/17.5 kV/24 kV order form

## Basic equipment

- To fill in the form, please check the boxes  that match your choices.
- Below accessories must be ordered separately:
  - Crank for manual circuit breaker racking in/out
  - Crank for charging the operating mechanism
  - 58-pole connector with female pins, loose component for use in low voltage cabinet

Basic equipment		Product range: HVX 12 kV ~ 24 kV <input type="checkbox"/>			Quantity <input type="text"/>
Version type	Withdrawable (E) <input type="checkbox"/>	Fixed (F) <input type="checkbox"/>			
Standard	IEC 62271-100 <input type="checkbox"/>				
Rated voltage	12 kV <input type="checkbox"/>		17.5 kV <input type="checkbox"/>	24 kV <input type="checkbox"/>	
Rated current	630 A <input type="checkbox"/>	1,250 A <input type="checkbox"/>	1,600 A <input type="checkbox"/>	2,000 A <input type="checkbox"/>	
	2,500 A <input type="checkbox"/>	3,150 A <input type="checkbox"/>	4000 A <input type="checkbox"/>		
Rated short-circuit current	25 kA <input type="checkbox"/>	31.5 kA <input type="checkbox"/>	40 kA <input type="checkbox"/>	50 kA <input type="checkbox"/>	
Phase distance (P)	150 mm <input type="checkbox"/>	210 mm <input type="checkbox"/>	275 mm <input type="checkbox"/>		
Opening release (F11)					
DC220V <input type="checkbox"/>	DC125V <input type="checkbox"/>	DC110V <input type="checkbox"/>	AC230V <input type="checkbox"/>	AC220V <input type="checkbox"/>	AC110V <input type="checkbox"/>
DC60V * <input type="checkbox"/>	DC48V * <input type="checkbox"/>	DC24V * <input type="checkbox"/>			
Closing release (F2)					
DC220V <input type="checkbox"/>	DC125V <input type="checkbox"/>	DC110V <input type="checkbox"/>	AC230V <input type="checkbox"/>	AC220V <input type="checkbox"/>	AC110V <input type="checkbox"/>
DC60V * <input type="checkbox"/>	DC48V * <input type="checkbox"/>	DC24V * <input type="checkbox"/>			
Charging motor (M1)					
DC220V <input type="checkbox"/>	DC125V <input type="checkbox"/>	DC110V <input type="checkbox"/>	AC230V <input type="checkbox"/>	AC220V <input type="checkbox"/>	AC110V <input type="checkbox"/>
DC60V * <input type="checkbox"/>	DC48V * <input type="checkbox"/>	DC24V * <input type="checkbox"/>			
Dimension drawing	Standard <input type="checkbox"/>				
Wiring diagram	Standard <input type="checkbox"/>	Non-standard <input type="checkbox"/>	Drawing No <input type="text"/>		
Type of earthing (withdrawable type only)					
Underneath earthing <input type="checkbox"/>		Side earthing <input type="checkbox"/>		Other <input type="text"/>	
Side earthing is only available for 12 kV/17.5 kV					
Low voltage plug type	58-pin plug-in connector <input type="checkbox"/>		Wiring by terminal block <input type="checkbox"/>		
Documentation language	English <input type="checkbox"/>				
Type of rack-in	Manual operating mechanism <input type="checkbox"/>		Motor operating mechanism * <input type="checkbox"/>		
Motor drive for racking trolley					
DC/AC220V * <input type="checkbox"/>	DC/AC110V * <input type="checkbox"/>	DC48V * <input type="checkbox"/>	Other (on request) * <input type="text"/>		
Available for all variant rating and phase distance. A motor controller is provided and attached to the circuit breaker. It is mandatory for the trolley motorization function.					
Operating sequence					
O-0.3 s-CO-3 min-CO Standard <input type="checkbox"/>		O-3 min-CO-3 min-CO <input type="checkbox"/>		O-0.3 s-CO-15 s-CO <input type="checkbox"/>	

# EvoPact HVX 12 kV/17.5 kV/24 kV order form

## Options and accessories

### Optional equipment 1

Anti-pumping relay (K01)	With <input type="checkbox"/>	Without <input type="checkbox"/>
Capacitor application	Yes <input type="checkbox"/>	No <input type="checkbox"/>

### Optional equipment 2

Blocking magnet on closing (Y1)					
DC220V <input type="checkbox"/>	DC125V <input type="checkbox"/>	DC110V <input type="checkbox"/>	AC230V <input type="checkbox"/>	AC220V <input type="checkbox"/>	AC110V <input type="checkbox"/>
DC60V * <input type="checkbox"/>	DC48V * <input type="checkbox"/>	DC24V * <input type="checkbox"/>			Without <input type="checkbox"/>

Blocking magnet on racking trolley (Y0)					
DC220V <input type="checkbox"/>	DC125V <input type="checkbox"/>	DC110V <input type="checkbox"/>	AC230V <input type="checkbox"/>	AC220V <input type="checkbox"/>	AC110V <input type="checkbox"/>
DC60V * <input type="checkbox"/>	DC48V * <input type="checkbox"/>	DC24V * <input type="checkbox"/>			Without <input type="checkbox"/>

Second opening release (F12)					
DC220V <input type="checkbox"/>	DC125V <input type="checkbox"/>	DC110V <input type="checkbox"/>	AC230V <input type="checkbox"/>	AC220V <input type="checkbox"/>	AC110V <input type="checkbox"/>
DC60V * <input type="checkbox"/>	DC48V * <input type="checkbox"/>	DC24V * <input type="checkbox"/>			Without <input type="checkbox"/>

Undervoltage release (F4)					
DC220V <input type="checkbox"/>	DC125V <input type="checkbox"/>	DC110V <input type="checkbox"/>	AC230V <input type="checkbox"/>	AC220V <input type="checkbox"/>	AC110V <input type="checkbox"/>
DC60V * <input type="checkbox"/>	DC48V * <input type="checkbox"/>	DC24V * <input type="checkbox"/>			Without <input type="checkbox"/>

Overcurrent release (F3)		1 A * <input type="checkbox"/>	5 A * <input type="checkbox"/>	Without <input type="checkbox"/>
--------------------------	--	--------------------------------	--------------------------------	----------------------------------

Interlock with door	With <input type="checkbox"/>	Without <input type="checkbox"/>
---------------------	-------------------------------	----------------------------------

Delivery time \* Long lead time

Special conditions (please contact Schneider Electric Application Engineer)

1 .....

2 .....

(For other requirements, please write here and attach relevant drawings or accessories)

Accessories	Drawing	Quantity
-------------	---------	----------

Accessories for EvoPact HVX withdrawable type

Crank for manual circuit breaker racking in/out	CHD8000092R0114	<input type="text"/>
Crank for charging the operating mechanism	AGSH30498-01	<input type="text"/>
58-pole connector with female pins, loose component for use in low voltage cabinet	ASXN00151-01	<input type="text"/>

Accessories for EvoPact HVX fixed type

Crank for charging the operating mechanism	AGSH30498-01	<input type="text"/>
58-pole connector with female pins, loose component for use in low voltage cabinet	ASXN00151-01	<input type="text"/>

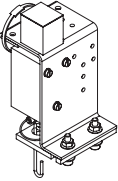
Opening release F11/F12				References		
EvoPact HVX voltage (kV)	12	17.5	24			
 DM103419-B	DC	•	•	•	24 V d.c.	AGSH31484-01
		•	•	•	48 V d.c.	AGSH31483-01
		•	•	•	60 V d.c.	AGSH31483-01
		•	•	•	110 V d.c.	AGSH31482-01
		•	•	•	125 V d.c.	AGSH31482-01
		•	•	•	220 V d.c.	AGSH31481-01
	AC	•	•	•	110/120 V a.c.	AGSH31482-01
		•	•	•	220/230 V a.c.	AGSH31481-01

AC magnets are operated with a rectifier.

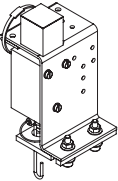
Closing release F2				References		
EvoPact HVX voltage (kV)	12	17.5	24			
 DM103419-B	DC	•	•	•	24 V d.c.	AGSH31484-01
		•	•	•	48 V d.c.	AGSH31483-01
		•	•	•	60 V d.c.	AGSH31483-01
		•	•	•	110 V d.c.	AGSH31482-01
		•	•	•	125 V d.c.	AGSH31482-01
		•	•	•	220 V d.c.	AGSH31481-01
	AC	•	•	•	110/120 V a.c.	AGSH31483-01
		•	•	•	220/230 V a.c.	AGSH31482-01

AC magnets are operated with a rectifier.

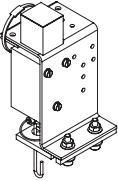
Overcurrent release (F3)				References		
EvoPact HVX voltage (kV)	12	17.5	24			
 DM103419-B	Without F12	•	•	•	1 A	AGSH31483-01
		•	•	•	5 A	AVXN01742-01
		•	•	•	5 A	AVXN01742-01
	With F12	•	•	•	5 A	AVXN01742-01

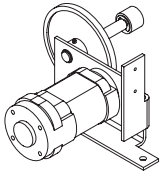
Charging motor (M1)				References		
EvoPact HVX voltage (kV)	12	17.5	24			
 DM103426-B	DC	•	•	•	24 V d.c.	AGSH33016-01
		•	•	•	48 V d.c.	AGSH33017-01
		•	•	•	60 V d.c.	AGSH33018-01
		•	•		110 V d.c. (Isc ≤ 31.5 kA, Ir ≤ 1,250 A)	AGSH33019-01
		•	•		110 V d.c. (Isc ≥ 40kA or Isc ≤ 31.5 kA, Ir ≥ 1,600 A)	AVXN00401-01
		•	•	•	125 V d.c.	AGSH33019-01
		•	•		220 V d.c. (Isc ≤ 31.5 kA, Ir ≤ 1,250A)	AGSH33020-01
		•	•		220 V d.c. (Isc ≥ 40 kA or Isc ≤ 31.5 kA, Ir ≥ 1,600 A)	AVXN00402-01
				•	110 V d.c. (Isc ≤ 25 kA, Ir ≤ 1,250 A)	AGSH33019-01
				•	110 V d.c. (Isc ≥ 31.5 kA or Ir ≥ 1,600 A)	AVXN00401-01
				•	220 V d.c. (Isc ≤ 25 kA, Ir ≤ 1,250 A)	AGSH33020-01
				•	220 V d.c. (Isc ≥ 31.5 kA or Ir ≥ 1,600 A)	AVXN00402-01
				•	110 V a.c. (Isc ≤ 31.5 kA, Ir ≤ 1,250 A)	AGSH33019-01
				•	110 V a.c. (Isc ≥ 40 kA or Isc ≤ 31.5 kA, Ir ≥ 1,600 A)	AVXN00401-01
				•	220 V a.c. (Isc ≤ 31.5 kA, Ir ≤ 1,250 A)	AGSH33020-01
				•	220 V a.c. (Isc ≥ 40kA or Isc ≤ 31.5 kA, Ir ≥ 1,600 A)	AVXN00402-01
				•	230 V a.c. (Isc ≤ 31.5 kA, Ir ≤ 1,250 A)	AGSH33020-01
				•	230 V a.c. (Isc ≥ 40 kA or Isc ≤ 31.5 kA, Ir ≥ 1,600 A)	AVXN00402-01
			•	110 V a.c. (Isc ≤ 25 kA, Ir ≤ 1,250 A)	AGSH33019-01	
			•	110 V a.c. (Isc ≥ 31.5 kA or Ir ≥ 1,600 A)	AVXN00401-01	
			•	220 V a.c. (Isc ≤ 25 kA, Ir ≤ 1,250 A)	AGSH33020-01	
			•	220 V a.c. (Isc ≥ 31.5 kA or Ir ≥ 1,600 A)	AVXN00402-01	
			•	230 V a.c. (Isc ≤ 25 kA, Ir ≤ 1,250 A)	AGSH33020-01	
			•	230 V a.c. (Isc ≥ 31.5 kA or Ir ≥ 1,600 A)	AVXN00402-01	

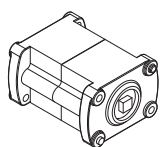
Auxiliary contacts				References		
EvoPact HVX voltage (kV)	12	17.5	24			
 DM105015	S11+S12	•	•	•	8NC+8NO	AVX002294-03

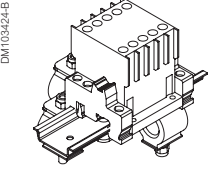
Anti-pumping relay K01				References		
EvoPact HVX voltage (kV)	12	17.5	24			
 DM103424-B	DC	•	•	•	24 V d.c.	AGSH31506-01
		•	•	•	48 V d.c.	AGSH31506-02
		•	•	•	60 V d.c.	AGSH31506-03
		•	•	•	110 V d.c.	AGSH31506-04
		•	•	•	125 V d.c.	AGSH31506-05
		•	•	•	220 V d.c.	AGSH31506-06
	AC	•	•	•	110 V a.c.	AGSH31506-07
		•	•	•	220/230 V a.c.	AGSH31506-08

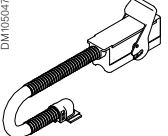
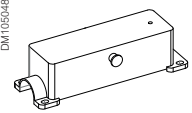
LV plug assembly on withdrawable/fixed circuit breaker				References	
EvoPact HVX voltage (kV)	12	17.5	24		
 DM105047	•	•	•	58-pole connector with male pins on CB side	ASXN00152-01M
 DM105048	•	•	•	58-pole connector with female pins, loose component for use in low voltage cabinet	ASXN00151-01

For the plug and socket system, pins, and special tools, please refer to the integration guide NVE6208301

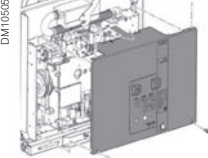
Front cover				References	
EvoPac HVX voltage (kV)	12	17.5	24		
 DM105657	•	•		Phase distance 150 mm	NNZ10147
	•	•		Phase distance 210 mm	NNZ10148
	•	•		Phase distance 275 mm	NNZ10185
			•	Phase distance 210 mm	NNZ10190
			•	Phase distance 275 mm	NNZ10194

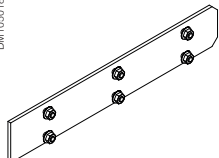
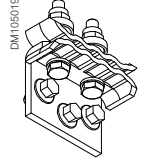
Earthing of the racking trolley				References	
EvoPact HVX voltage (kV)	12	17.5	24		
 <p>DM105018</p> <p>Underneath earthing</p>	 <p>DM105019</p> <p>Side earthing</p>	• •	Side earthing of trolley	AVXN01856-01M	
		• •	Underneath earthing of trolley (PD = 275 mm)	AVXN01856-03M	
		• •	Underneath earthing of trolley (PD = 150 mm/210 mm)	AVXN01856-02M	
			•	Underneath earthing of trolley (PD = 210 mm)	AVXN01856-04M
			•	Underneath earthing of trolley (PD = 275 mm)	AVXN01856-05M

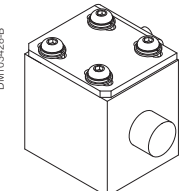
Blocking magnets on racking trolley (Y0)				References	
EvoPact HVX voltage (kV)	12	17.5	24		
 <p>DM103428-B</p>	DC	• • •	24 V d.c.	ASX000597-01	
		• • •	48 V d.c.	ASX000597-03	
		• • •	60 V d.c.	ASX000597-08	
		• • •	110 V d.c.	ASX000597-04	
		• • •	125 V d.c.	ASX000597-05	
		• • •	220 V d.c.	ASX000597-06	
	AC	• • •	230 V d.c.	ASX000597-07	
		• • •	110 V a.c.	ASX000597-04	
		• • •	220 V a.c.	ASX000597-06	
		• • •	230 V a.c.	ASX000597-07	

AC magnets are operated with a rectifier

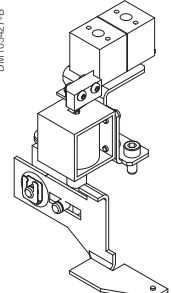
Blocking magnets on closing (Y1)				References	
EvoPact HVX voltage (kV)	12	17.5	24		
 <p>DM103427-B</p>	DC	• • •	24 V d.c.	AVXN00186-08	
		• • •	48 V d.c.	AVXN00186-06	
		• • •	60 V d.c.	AVXN00186-05	
		• • •	110 V d.c.	AVXN00186-04	
		• • •	125 V d.c.	AVXN00186-03	
		• • •	220 V d.c.	AVXN00186-02	
	AC	• • •	230 V d.c.	AVXN00186-01	
		• • •	110 V a.c.	AVXN00186-04	
		• • •	220 V a.c.	AVXN00186-02	
		• • •	230 V a.c.	AVXN00186-01	

AC magnets are operated with a rectifier

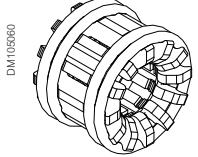
Clusters				References
EvoPact HVX voltage (kV)	12	17.5	24	
	•	•	•	Ir = 630 A, I <sub>sc</sub> ≤ 25 kA ASXN00439-06
	•	•	•	Ir = 630 A, I <sub>sc</sub> = 31.5 kA or Ir=1,250 A , I <sub>sc</sub> ≤ 31.5 kA ASXN00439-07
	•	•		Ir ≤ 1,250 A, I <sub>sc</sub> = 40 kA or Ir = 1600/2000 A, I <sub>sc</sub> ≤ 40 kA ASXN00439-02
	•	•		Ir = 1250/1600/2000 A, I <sub>sc</sub> = 50 kA ASXN00439-03
	•	•		Ir = 2,500/3,150/4,000 A, I <sub>sc</sub> ≤ 40 kA ASXN00439-04
	•	•		Ir = 2,500/3,150/4,000 A, I <sub>sc</sub> = 50 kA ASXN00439-05
			•	Ir = 1,600/2,000/2,500 A, I <sub>sc</sub> ≤ 31.5 kA ASXN00439-02

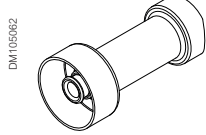
Arms				References
EvoPact HVX voltage (kV)	12	17.5	24	
	•			Ir = 630 A, I <sub>sc</sub> ≤ 31.5 kA AVXN00372-01
	•			Ir = 1250 A, I <sub>sc</sub> ≤ 31.5 kA AVXN00672-01
		•		Ir = 630 A, I <sub>sc</sub> ≤ 31.5 kA AVX8000009R0101
		•		Ir = 1250 A, I <sub>sc</sub> ≤ 31.5 kA AVX8000008R0101
	•	•		Ir ≤ 1,250 A, I <sub>sc</sub> ≥ 40 kA or Ir = 1,600/2,000 A, I <sub>sc</sub> ≤ 50 kA ASXN00745-21
	•	•		Ir = 2,500/3,150/4,000 A, I <sub>sc</sub> ≤ 50 kA ASXN00745-22M
			•	Ir = 630/1,250 A, I <sub>sc</sub> ≤ 25 kA ASXN00661-01
			•	Ir = 630 A/1,250 A , I <sub>sc</sub> = 31.5 kA AVX8020001R0101
			•	Ir = 1,600/2,000 A/ 2,500 A, I <sub>sc</sub> ≤ 31.5 kA ASXN00661-21

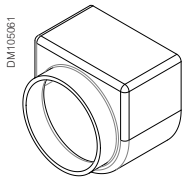
Insulating sleeves				References
EvoPact HVX voltage (kV)	12	17.5	24	
	Ir ≤ 1,250 A I <sub>sc</sub> ≤ 31.5 kA	Ir ≤ 1,250 A I <sub>sc</sub> ≤ 31.5 kA	Ir ≤ 1,250 A I <sub>sc</sub> ≤ 25 kA	CHD8000134P0104
	Ir ≤ 1,250 A I <sub>sc</sub> ≥ 40 kA or Ir ≥ 1,600 A	Ir ≤ 1,250 A I <sub>sc</sub> ≥ 40 kA or Ir ≥ 1,600 A	Ir ≤ 1,250 A I <sub>sc</sub> ≥ 31.5 kA or Ir ≥ 1,600 A	NVE44473

Note: For adaptation and modification, please contact Schneider Electric.



Notes

---

# L-Frame cradle

# L-Frame cradle

---

Introduction	68
L-Frame cradle references	70
Dimensions	71

---

The L-Frame cradle is supplied as a self-supporting frame, including all interlocks and racking features, and provides a reliable and cost-effective solution for integration in a wide range of indoor Air Insulated Switchgear.

The L-Frame cradle brings the benefits of Schneider Electric proven technology to the design and manufacture of withdrawable switchgear cubicles.

It provides to our Partners a complete solution with connection of the circuit breaker to the contacts in the bushings and allows the Partners to focus and shorten the design of the switchgear.

## Cradle for integration of switching devices

**The L-Frame cradle** is delivered fully assembled and ready for integration of EvoPact HVX Embedded Pole circuit breakers and consists of:

- A left and a right sides frames
- Shutters with their shutter mechanisms
- Rails for guiding the circuit breaker from test to service position
- Bushings with fixed contacts
- Copper bars for connection to the main Busbar of the switchgear
- Two holes on the front of the L-Frame cradle for guiding and aligning the extraction table
- A self-supporting frame
- To meet IP2X according to IEC60529, IP cover should be designed and installed to VCB and L-frame cradle dimensions.

As an option, it includes a fully rated and interlocked earthing switch. It can give to the Partners the advantage of a type tested solution for the earthing switch.

**The earthing switch** is assembled and set by the Schneider Electric manufacturing plant. For 12 kV/17.5 kV, only the fixed contacts (quantity 3 delivered with the L-Frame cradle as loose components) will have to be assembled and adjusted on the main circuit of the switchgear. For 24 kV, the fixed contacts are assembled and set by the Schneider Electric manufacturing plant.

The earthing switch includes:

- An operating mechanism mounted on the right side of the L-Frame cradle
- A power circuit unit with a fast-acting closing mechanism independent of the operator
- A mechanical interlocking with the circuit breaker and prevents:
  - racking in the circuit breaker if the earthing switch is closed
  - closing the earthing switch if the circuit breaker is not opened and fully racked out

PM105844



EvoPact HVX embedded pole and L-frame cradle

PM105845



Earthing switch

## According to IEC 62271-200

PM1.05644



Designation		Dimensions and electrical characteristics				
Phase distance (mm)			150	210	275	
Rated Voltage	Ur	kV	12	•	•	•
			17.5	•	•	•
			24		•	•
Rated frequency	fr	Hz	50 / 60	•	•	•
			28(1)	•	•	•
Rated short duration power frequency withstand voltage	Ud	kV	38	•	•	•
			50		•	•
			75	•	•	•
Rated lightning impulse withstand voltage	Up	kV	95	•	•	•
			125		•	•
			25	•	•	•
Rated short-time withstand current	Ik	kA	31.5	•	•	•
			40	•	•	•
			3	•	•	•
Rated normal current	Ir	A	630	•	•	•
			1 250	•	•	•
			1 600 / 2 000		•	•
			2 500 / 3 150			•
Preferred cubicle width		mm	650	800	1000	

(1) In accordance with GOST standard: 42 kV 5 min

## Cradle without earthing switch

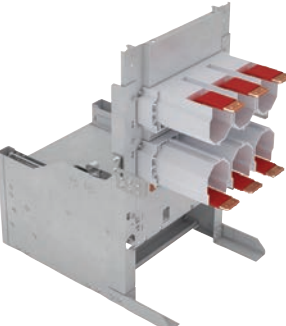

Phase distance (mm)			150	210	275
up to 17.5 kV	Up to 1 250 A	Up to 31.5 kA	AVXN10478-11	AVXN10478-03	-
		40 kA	-	AVXN10478-05	-
	1 600 A / 2 000 A	Up to 40 kA	-	AVXN10478-05	-
24 kV	2 500 A / 3 150 A	Up to 40 kA	-	-	AVXN10478-08
	Up to 1 250 A	Up to 31.5 kA	-	CHD8120075R0105	CHD8120075R0111
			-	-	CHD8120075R0131
2 500 A		-	-	CHD8120075R0118	

## Cradle with earthing switch

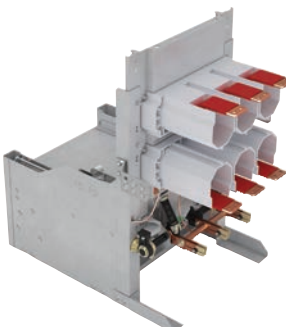

Phase distance (mm)			150	210	275
up to 17.5 kV	Up to 1 250 A	Up to 31.5 kA	AVXN10478-02	AVXN10478-04	-
		40 kA	-	AVXN10478-06	-
	1 600 A / 2 000 A	Up to 40 kA	-	AVXN10478-06	-
24 kV	2 500 A / 3 150 A	Up to 40 kA	-	-	AVXN10478-07
	Up to 1 250 A	Up to 31.5 kA	-	CHD8120075R0137	CHD8120075R0146
			-	-	-
2 500 A		-	-	CHD8120075R0163	

### Earthing Switch handle

### Description

### Reference



Earthing switch operating handle

CHD1000063P0005

**Note:** The 12 kV cradle may be used for 7.2 kV rated voltage / Please contact your Schneider Electric sales representative for more information

# Dimensions

Without earthing switch

Up to 17.5 kV

Up to 31.5 kA / Up to 1 250 A

Phase distance 150 mm

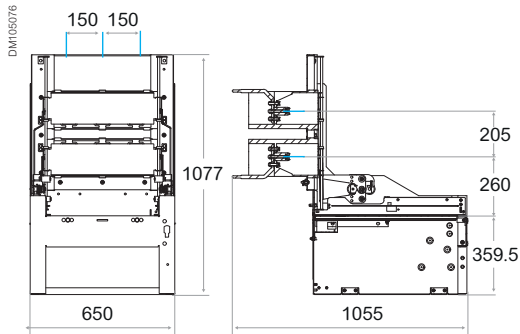

Phase distance 210 mm

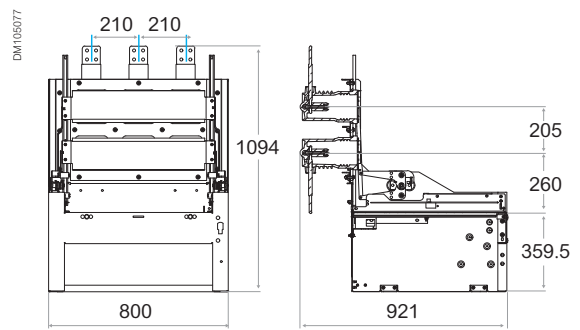

40 kA / Up to 1 250 A, up to 40 kA / 1 600 A - 2 000 A

Phase distance 210 mm

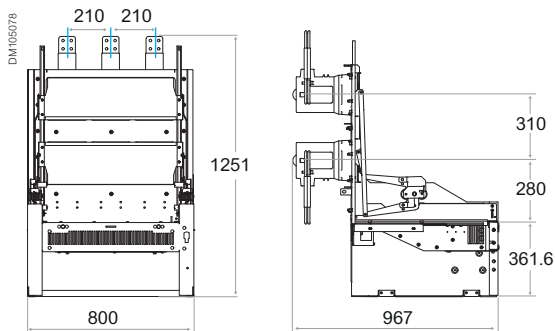

Up to 40 kA / 2 500 A - 3 150 A

Phase distance 275 mm

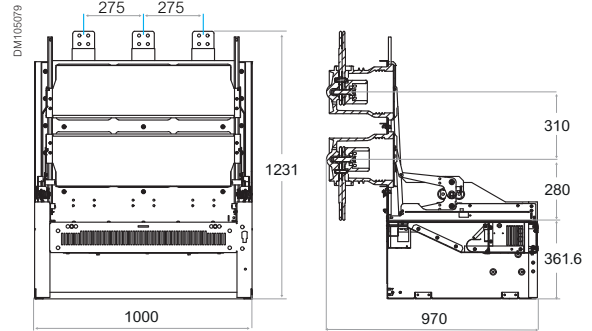

# Dimensions

Without earthing switch

24 kV

Up to 31.5 kA / Up to 1 250 A

Phase distance 210 mm

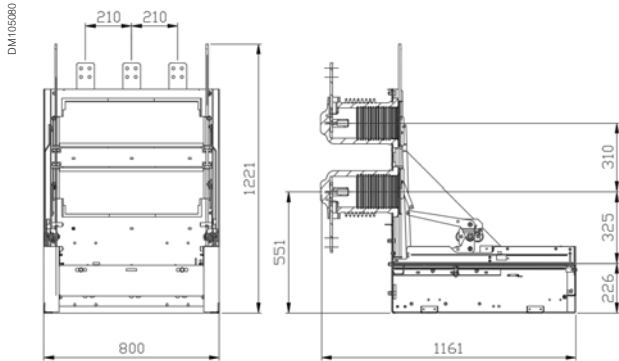

Phase distance 275 mm

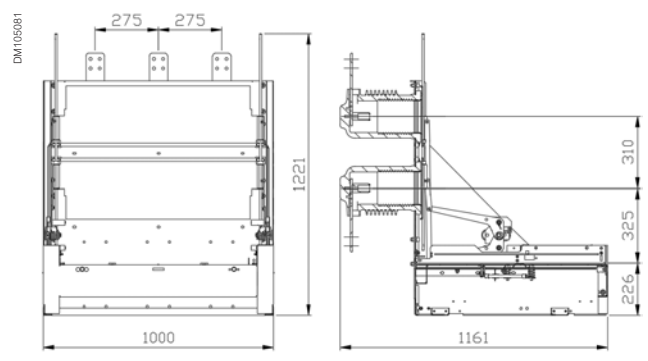

Up to 31.5 kA /  
1 600 A - 2 000 A

Phase distance 275 mm

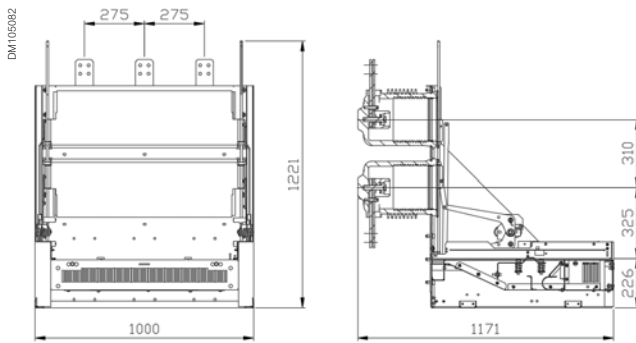

Up to 31.5 kA /  
2 500 A

Phase distance 275 mm

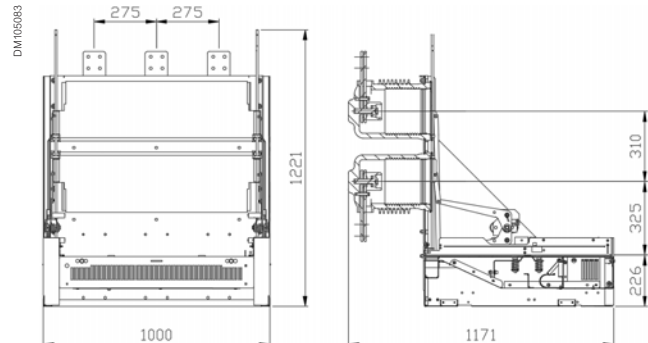



# Dimensions

## With Earthing switch

Up to 17.5 kV

Up to 31.5 kA / Up to 1 250 A

Phase distance 150 mm

Phase distance 210 mm

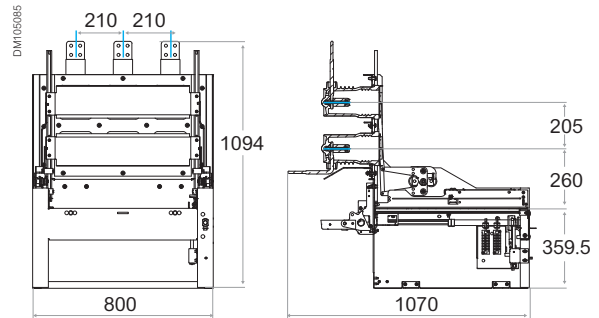
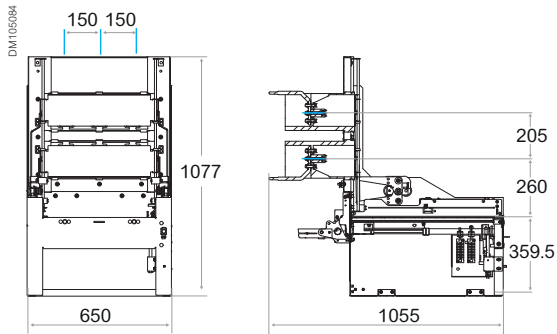

Up to 40 kA / 1 600 A - 2 000 A, 40 kA /  
Up to 1 250 A

Phase distance 210 mm

Up to 40 kA /  
2 500 A - 3 150 A

Phase distance 275 mm

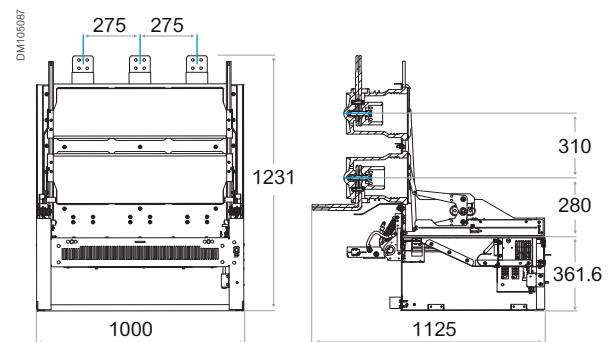
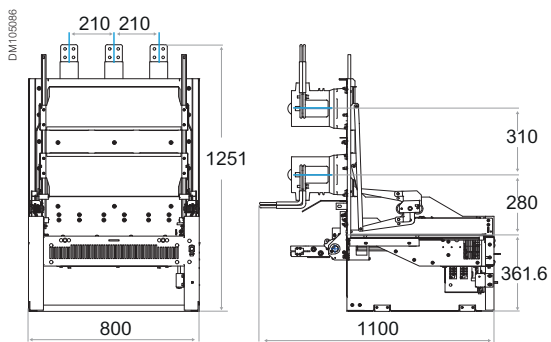

# Dimensions

## With Earthing switch

24 kV

Up to 31.5 kA / Up to 1 250 A

Phase distance 210 mm

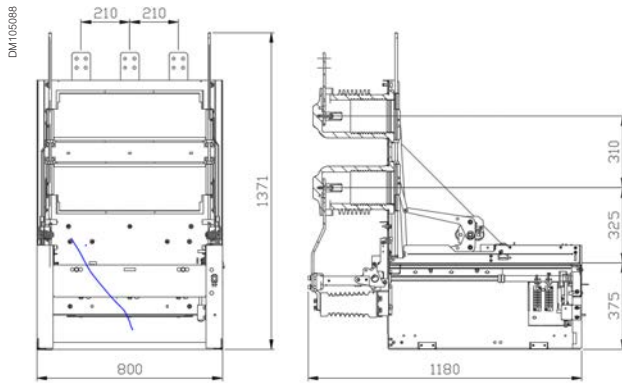

Phase distance 275 mm

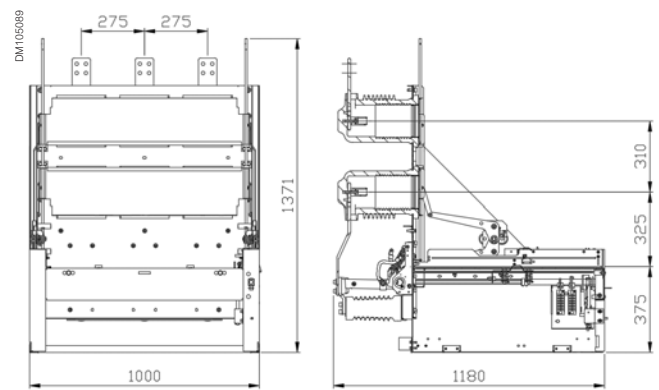

Up to 31.5 kA / 2 500 A

Phase distance 275 mm

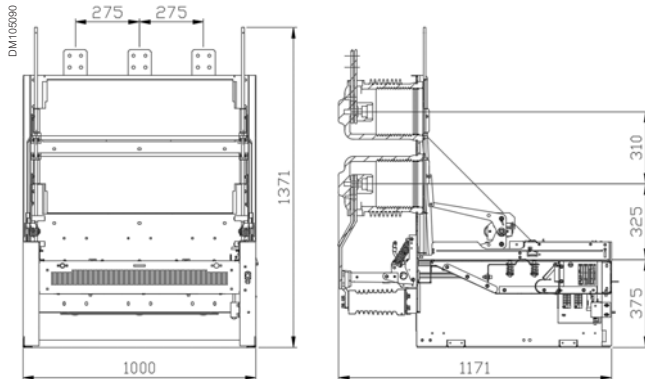

Notes

---

# DIGITAL TOOLS

## se.com

This international web site allows you to access all the Schneider Electric solutions and product information via:

- Comprehensive descriptions
- Range datasheets
- A download area
- Product selectors

You can also access information dedicated to your business and contact your Schneider Electric country support.

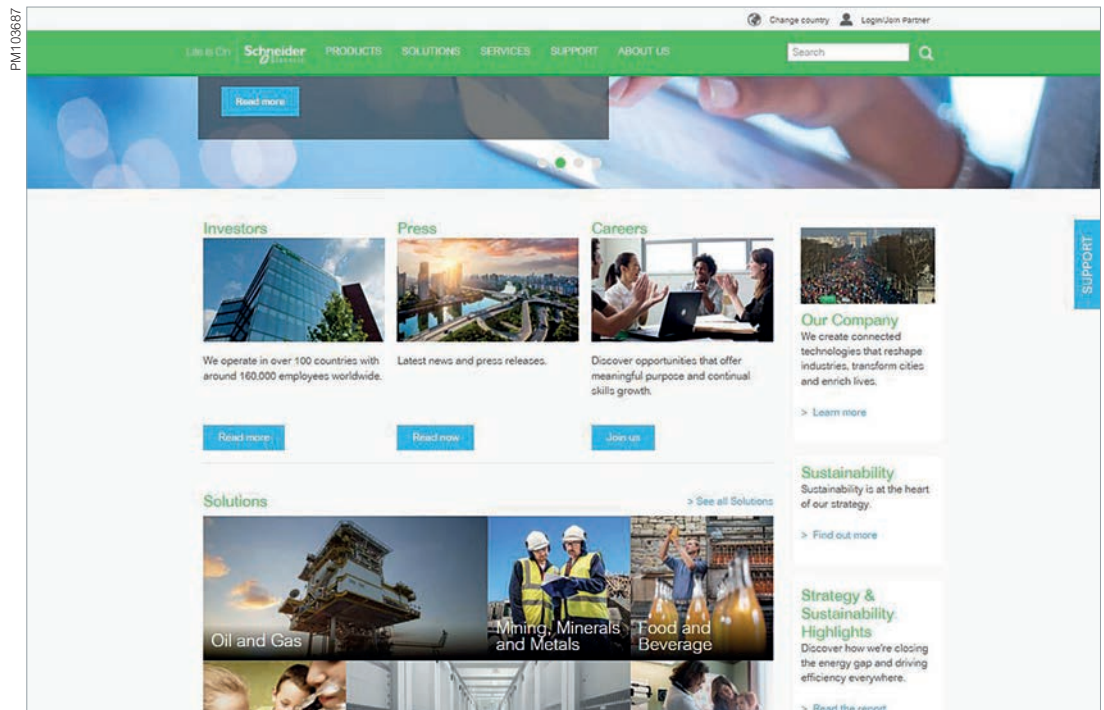

# How can digital bring more value at work?

Simplify your life at all steps of your business

## Connect Panel Builder Portal

The Schneider Electric™ Panel Builder Portal can help you find what you need to create better, more efficient Low Voltage or Medium Voltage Switchboards, in less time.

 [panel builders web page](#)

### You'll get:

- Productivity tools
- Personalized resources
- Collaborative sales support
- Trainings

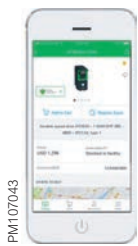

### Get support anytime

- 24/7 self-service, mobile catalog and access to expert help
- Off-line and on-line catalog
- Manage and track your orders
- Advanced support

 [MySchneider App](#)



### Discover, select and define

Experience our advanced WEB functionalities that help to:

- Select and compare components
- Build easily and automatically your technical documentation with ready to use tools

 [www.se.com](#)



### Order and check ordering information

A self-service ordering platform to access detailed information:

- Check real-time price and availability information
- Order online
- Check order status and tracking information
- Get financial documentation

 [mySE](#)

With  
Schneider Electric  
Partner Program,

get more  
done!

Think big.  
Partner up!

Visit our page and get more:

 [panel builders web page](#)

Life Is On

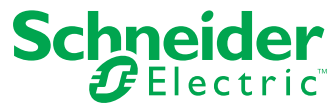

Green Premium™ ecolabel product -  
Sustainable performance, by design

Schneider Electric Industries SAS  
35, rue Joseph Monier - CS 30323  
F92506 Rueil-Malmaison Cedex