

PowerLogic™ P5

Catalog 2023

Network Protection and Control Relays



Note: Electrical power systems are dangerous, protection relays are defined and governed by international standards such as IEC 60255 “Measuring relays and protective equipment” and IEEE C37.97 “Protective relay applications to power systems buses”. Never attempt to install or operate protection relays or associated equipment without the necessary qualifications, training and tools. Exposure to electrical arc-flash incidents can be life threatening, no situation can ever be deemed fully safe. Standards such as NFPA 70E define important risk categorization and such standards identify both distance from, and energy of the arc incident to be important factors. In order to reduce the risk category and improve safety during arc-flash incidents, functionality is available in PowerLogic P5 protection relays: i) to operate electrical panel from a safer distance via wireless communication, and ii) to detect and limit the arc energy by tripping the connected circuit breaker faster than in a conventional protection scheme.

General Contents

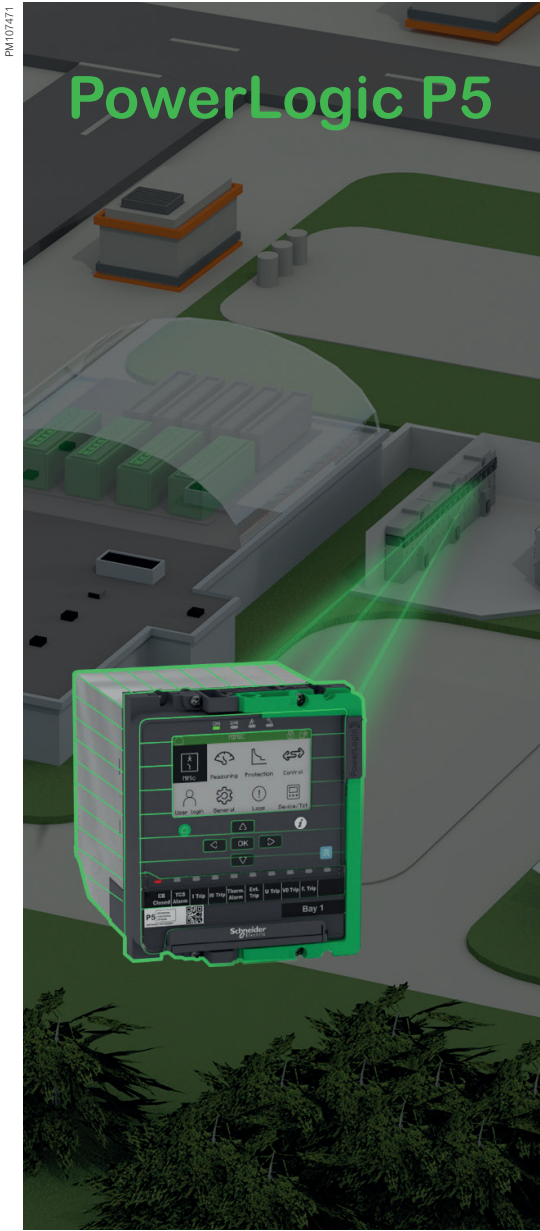

Range Description [4](#)

Product Description [50](#)

Digital Experience [80](#)

Additional Modules and Accessories [86](#)

Services [102](#)

Ordering [108](#)

PowerLogic P5 Range Description

PowerLogic P5 Range Description

Overview	10
Selection Guide	11
Selection Guide by Functionality	12
Selection Guide by Application	14
Feeder/Incomer application	14
Motor application	15
Transformer application	16
Arc-flash application	18
Capacitor application	19
Functions and Description	20
Automation and Control	41
Communication	42
Examples of architectures	42
Redundancy protocols	43
Time synchronization	44
Data exchanged	45
Focus on IEC 61850 protocol	46
Cybersecurity	47
Cybersecurity - Basic level	47
Cybersecurity - Advanced level	48

The PowerLogic P5 at a glance



The PowerLogic P5 is a protection relay for demanding medium-voltage applications. It offers users industry-leading dedicated protection relay functionality to reduce risks, improve reliability, all with advanced connectivity. Additionally, it can be used with a range of digital tools that make everyday operations simpler for users. The PowerLogic P5 is part of the PowerLogic range of power monitoring and control solutions and has been built on more than 100 years of experience in protection relays, including Sepam, MiCOM, and Vamp ranges, renowned for their reliability and performance.

Industry-leading protection functions

- Built-in arc-flash protection function (optional)
- Nearby control with a mobile application
- Latest cybersecurity built in, certified according to IEC 62443 4-2 Security Level 1 and Achilles Level 2

Best-in-class reliability

- Withdrawable design for quicker maintenance
- Backup memory function enabling industry-leading 10 minute recovery time!
- Condition monitoring for reduced risk of power outages and maximized equipment life
- Extended equipment lifetime when used with EcoStruxure Asset Advisor

Maximized everyday simplicity

- Easier operation with digital tools including the EcoStruxure Power Device app
- Powerful communication with plug and play ports and seven protocols supported
- Scalable hardware making it easy to upgrade as your applications evolve

Enjoy a package of sought-after features in one device



The PowerLogic P5 is a major step forward for protection relays, combining best-in-class features together in one device.

Built-in arc-flash protection functions

Arc-flashes will always exist when switching or during unexpected conditions. If the protection function detects an arc-flash, it isolates the connected circuit breaker within milliseconds, preventing a growing arc-flash energy and thus an unexpected risk of outage.

Advanced cybersecurity

With its optional cybersecurity package the PowerLogic P5 is one of the first protection relays to be third-party certified according to IEC 62443 4-2 standard at Security Level 1. This means reduced exposure to cyber threats and improved operational security. By default, the PowerLogic P5 includes important features such as password management, port hardening and secured communication compliant to the latest standards.

Intuitive withdrawable design

With a handle built in as part of the design, the P5 can be quickly disconnected or exchanged to speed up maintenance. Wiring, data, communication, and settings (including backup) can be stored with the panel and will be there when the relay is reconnected.

Improved recovery time

When maintenance or testing is required, PowerLogic P5 helps dramatically decrease your outage recovery time. The backup memory can automatically restore settings, you can continue your operations in as little as 10 minutes.*

*Result of mean time to repair (MTTR) calculation conducted by Schneider Electric

Greater connectivity

The protection relay features seven communication protocols. This includes compliance with IEC 61850 Edition 1 and Edition 2, Modbus (serial/TCP), IEC 60870-5-103, IEC 60870-5-101, Ethernet/IP, and DNP3 (serial/TCP). PowerLogic P5 can support up to 3 Ethernet protocols simultaneously, including offering dual redundancy with PRP/HSR and RSTP protocols. Moreover, all communication modules can be added at any time, including on-site, during the product life cycle to allow you to upgrade your device in line with future network evolutions.



Make everyday operations easier with digital tools

The PowerLogic P5's industry leading protection features are complemented by a comprehensive set of tools available on mobile devices such as smartphones or tablets, and desktop computers. This means you get simpler installation, configuration, and maintenance, enabling you to save time and money. Nearby control and monitoring allows users to fully operate the device via wireless communication, from a safer distance.



Digital tools for the PowerLogic P5 include:

- **EcoStruxure Power Build** – Medium Voltage online ordering tool enables quicker and easier ordering
- **eSetup Easergy Pro** software with virtual injection testing
- Embedded web server, allowing easy and fast setting changes from a web browser
- **EcoStruxure™ Power Device app** for simpler and safer operation and maintenance
- **mySchneider app**, a simple way to access support and product data by flashing the QR code on the device

As an EcoStruxure-ready solution, the PowerLogic P5's digital benefits can be taken even further with best-in-class monitoring of substation equipment health. For example, when paired with **EcoStruxure Asset Advisor**, users get data for predictive maintenance, which helps them reduce OpEx, speed up processes, and boost efficiency.

Take PowerLogic P5 further with EcoStruxure™

EcoStruxure, Schneider Electric's IoT-enabled, open and interoperable architecture and platform, brings together Connected Products, Edge Control, and Apps, Analytics & Services. EcoStruxure connected products deliver enhanced value around safety, reliability, efficiency, sustainability, and connectivity.

450 000

EcoStruxure systems deployed since 2007 with the support of our 9,000 system integrators

EcoStruxure ready



Efficient asset management

Boost your efficiency and reduce downtime using predictive maintenance tools



24/7 connectivity

Make better informed decisions with real-time data that's available everywhere, anytime

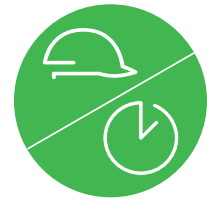

Enhanced safety

Advanced features designed-in based on well-known designs, experience and technology

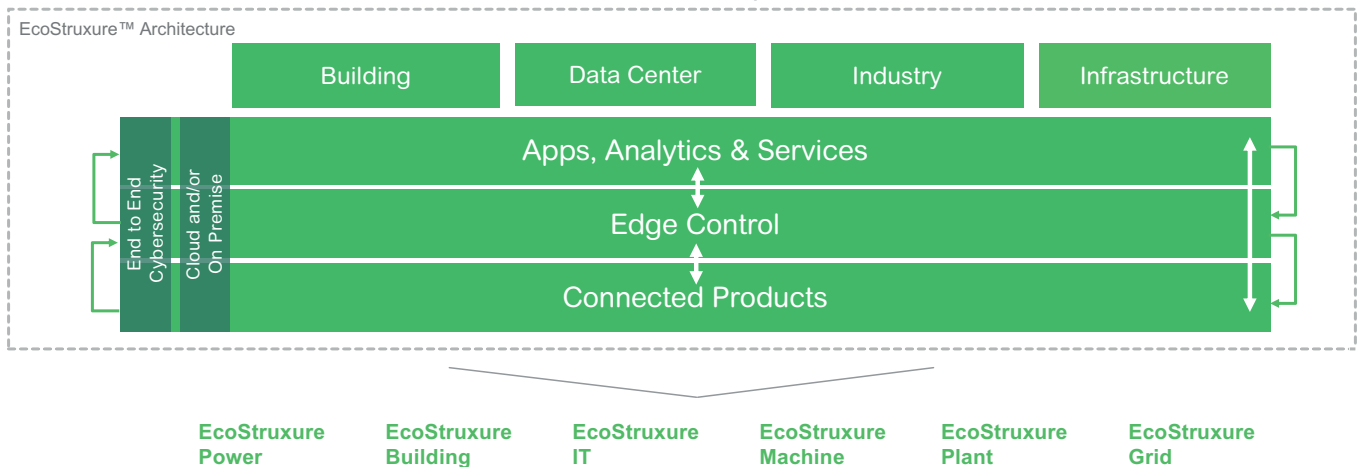

PowerLogic P5 protection relay is based on proven technology concepts and developed in close cooperation with customers, so it's built to meet your toughest demands:

- Modular design that allows user-defined conventional protection and arc-flash protection solutions.
- Compatible with conventional CTs/VTs or low power instrument transformers LPCT/LPVT compliant to IEC 61869-10 and IEC 61869-11.
- Embeds latest cybersecurity functionality to help prevent intentional mis-use and cyber-threats.
- Fast replacement with enhanced safety thanks to withdrawability and back-up memory that automatically restore parameters without using any configuration tools.
- Advanced logic engine (option) supports the most complex automation & control schemes.

PowerLogic products are designed to be user friendly, a feature that is proven in our customer reports day after day. You'll benefit from features that include:

- A complete set of protection functions, related to the application.
- Arc-flash detection in PowerLogic P5x30 models.
- Dedicated circuit breaker control with single-line diagram, push buttons, programmable function keys, LEDs, and customizable alarms.
- Multilingual HMI for customized messaging.
- Settings tool relay management software for setting parameters, configuring, and network fault simulation.
- Both serial and Ethernet communication, including redundancy.
- IEC 61850 communication protocol including flexible product naming for smooth multi-vendor integration.

PowerLogic P5 is available in two sizes to best fit your needs:



PowerLogic P5 digital protection relays are designed for power distribution networks in:

- Utilities - Energy distribution
- Critical buildings and Industry:
 - Data Center
 - Healthcare
 - Transportation
 - Industrial buildings
- Large industrial processes:
 - Oil and Gas
 - Mining
 - Mineral and Metals
 - Water

Range overview

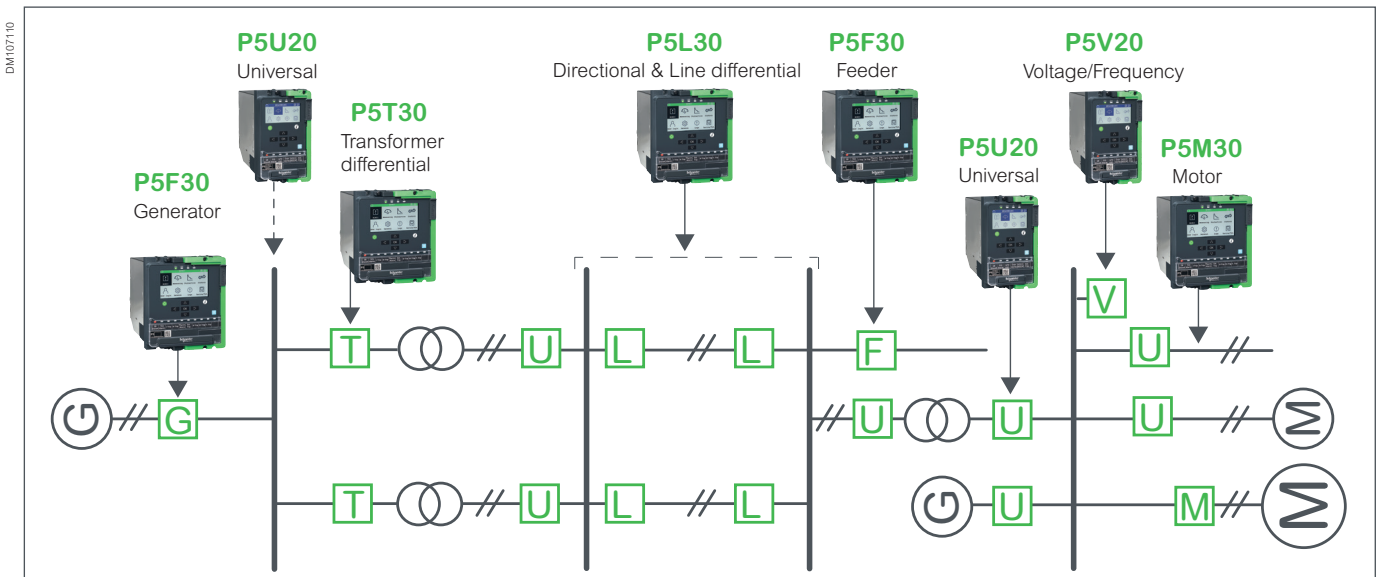

PowerLogic P5 contains two main devices, each with specific functions to address your needs in a one-box design, regardless of application.		PowerLogic P5x20		PowerLogic P5x30	
		P5V20	-	-	-
Voltage					
Feeder					
Transformer			P5U20 with directional in LPCT/LPVT version	P5F30 with directional	-
Motor					P5T30
Characteristics				P5M30 with directional	-
Measuring inputs	Phase current	-	1/5A CT (x3) or LPCT (x3) ⁽¹⁾	1/5A CT (x3) or LPCT (x3)	1/5A CT (x6)
	Residual current	-	1/5A CT & 1A CT or CSH core balance CT	1/5A CT & 1A CT or CSH core balance CT	1/5A CT (x2)
	Voltage	VT (x4)	LPVT (x4) ⁽¹⁾	VT (x4) or LPVT (x4)	VT (x1)
Arc-flash sensor inputs			-		0 to 6 point sensors
Digital	Inputs		4 to 16		4 to 40
	Outputs		3 to 8 + Watchdog (WD)		3 to 18 + Watchdog (WD)
Temperature sensor input		-	0 to 16 (external modules)		0 to 16 (external modules)
Front ports			1 USB for configuration 1 USB for USB key		1 USB for configuration 1 USB for USB key
Power supply			24-250 VDC ; 100-230 VAC		24 - 48 VDC or 48-250 VDC ; 100-230 VAC
Ambient temperature, in service			-40 to 70°C (-40 to 158°F)		-40 to 70°C (-40 to 158°F)
Communication					
Hardware modules	Extension ⁽²⁾ + Backup memory		●		●
	Serial		●		●
	Ethernet		●		●
	2 nd Ethernet		-		●
Protocols	IEC 61850 Ed.1 & Ed.2		●		●
	IEC 60870-5-103 & 101		●		●
	DNP3 Ethernet		●		●
	DNP3 serial		●		●
	Modbus Ethernet		●		●
	Modbus serial		●		●
	EtherNet IP		●		●
Redundancy protocols	RSTP		●		●
	PRP / HSR		●		●
Time synchronization	Pulse, IRIG-B ⁽³⁾		●		●
	SNTP, PTP IEEE 1588 v2 ⁽⁴⁾		●		●
Others					
Control			6 controlled + 2 monitored objects Mimic		6 controlled + 2 monitored objects Mimic
Logic (Matrix + Programmable logic)			●		●
Optional Advanced Logic Engine (order option)			●		●
Cybersecurity			Basic or Advanced		Basic or Advanced
Draw-out device (withdrawability)			●		●
Hardware dimensions (W/H/D)			102 / 176 / 219 mm 4.01 / 6.93 / 8.62 in		152 / 176 / 219 mm 6.0 / 6.93 / 8.62 in

(1) In case P5U20 is chosen for cooperation with low power sensors, it contains LPCT (x3) and LPVT (x4) channels

(2) for connection of RTD module and IRIG-B module

(3) IRIG-B module is a separate accessory

(4) PTP IEEE 1588 v2 is available with HSR/PRP communication board

Selection Guide by Functionality

Protection Functions	ANSI code	IEC 61850 Logical Node	P5V20 VT variant	P5U20 CT variant	P5U20 LPCT/LPVT variant	P5F30 CT/VT variant LPCT/LPVT variant	P5M30 CT/VT variant LPCT/LPVT variant	P5T30 CT/VT variant
Current protection								
Non-direction or directional phase overcurrent ⁽¹⁾	50/51/67	OCPTOC	-	6	6	6	6	6
Non-directional or directional earth/ground fault ⁽²⁾	50N/51N 50G/51G 67N	DEFUPTOC	-	6	6	6	6	6
Transient intermittent/ground fault	67NI	IOIOPTEF	-	-	-	1	-	-
Neutral admittance	21YN	EFPADM	-	-	-	2	2	-
Negative sequence overcurrent	46 (I2/I1)	NEGPTOC	-	2	2	2	2	2
Current unbalance, Broken conductor	46BC (I2)	UIBCPTOC	-	2	2	2	-	2
Breaker failure	50BF	CBFPPIOC	1	1	1	1	1	2
Phase undercurrent	37	UCPTUC	-	1	1	1	1	-
Low Impedance Restricted earth/ground fault ⁴	64REF	REFPDIF	-	1	-	1	1	2
High impedance restricted earth/ground fault ⁴	87N	-	-	A	-	A	A	A
High impedance busbar differential ⁴	87BB	-	-	A	-	A	A	A
Switch on to fault (SOTF)	50HS	SOTFPIOC	-	1	1	1	1	-
Cold load pickup (CLP or CLPU)	-	CLPPIOC	-	1	1	1	1	-
Voltage controlled overcurrent	51V	-	-	A	A	A	A	-
Voltage protection								
Undervoltage	27	OFPTOF	3	-	3	3	3	-
Overvoltage	59	OVPTOV	3	-	3	3	3	-
Neutral voltage displacement	59N	UOPTOV	3	-	3	3	3	3
Negative sequence overvoltage	47	NEGPTOV	2	-	2	2	2	-
Frequency protection								
Overfrequency	81	OFUPTOF	2	-	2	2	2	-
Underfrequency	81U	UFPTUF	8	-	8	8	8	-
Rate of change of frequency (RoCoF)	81R/81RE	DFDTPFRC	9	-	9	9	-	-
Thermal protection								
Thermal overload	49	THFPTR	-	1	1	1	1	1
Temperature monitoring	38	RTDGAPC	-	16	16	16	16	16
Power protection								
Wattmetric earth/ground fault	32N	EFPDOP	-	-	-	2	2	-
Directional active underpower	32P	REVPPDOP	-	-	2	2	2	-
Rotating machine protection								
Frequent start inhibition	66	FSTPMRI	-	1	1	-	1	-
Motor start-up supervision, locked rotor	48/51LR	STALPMSS	-	1	1	-	1	-
Positive sequence undervoltage	27P	UVPSPTUV	2	-	-	-	2	-
Underspeed ⁽³⁾	14	MOTPSZU	-	2	2	-	2	-
Overspeed ⁽³⁾	12	MOTPOVS	-	2	2	-	2	-
Anti-backspin ⁽³⁾	ABS	MABSPMSS	-	1	1	-	1	-
Emergency restart	-	-	-	1	1	-	1	-
Line protection								
Fault locator	21FL	FLRFLO/ SCRFLLO	-	-	-	1	-	-
Auto-Recloser	79	ARRREC	-	1	1	1	-	-
Transformer protection								
Inrush / 2nd harmonic detection	68H2	IDPHAR	-	1	1	1	1	2
Fifth harmonic detection	68H5	HAR5PTOC	-	1	1	1	1	-
2-winding transformer differential	87T	OCPDIF	-	-	-	-	-	1
Thermostat / Buchholz	26/63	TRFSIML	-	-	-	-	-	2
Overfluxing	24	TVFPVPH	-	-	-	-	-	3
Capacitor protection								
Capacitor bank unbalance	51C	CAPPTOC	-	2	-	2	-	-
Capacitor overvoltage	59C	CAPPTOV	-	1	-	1	-	-
Other protection								
Arc-flash detection	50ARC	ARCMPIOC	-	-	-	8	8	8
Programmable stages	99	PSGAPC	8	8	8	8	8	8
Programmable curves	-	-	3	3	3	3	3	3
Control, monitoring, supervision								
Synchronization check	25	RSYN	1	-	-	1	-	-
Lockout relay	86	-	1	1	1	1	1	1
CT supervision	60	CTSGGIO	-	1	1	1	1	2
VT supervision	60	VTSGGIO	1	-	1	1	1	-
Setting groups	-	-	4	4	4	4	4	4

(1) Only non-directional phase overcurrent is available in P5U20 CT variant and P5T30.
(2) Only non-directional earth/ground fault overcurrent is available in P5U20 CT variant.

(3) Function available if 12 BI / 4 BO board is present.
(4) Only available with conventional (phase or neutral) CTs
A Function available by application guidelines

Selection Guide by Functionality (cont'd)

Control functions	P5V20 VT variant	P5U20 CT variant	P5U20 LPCT/LPVT	P5F30 CT/VT variant LPCT/LPVT variant	P5M30 CT/VT variant LPCT/LPVT variant	P5T30 CT/VT variant	
Control with Mobile application	●	●	●	●	●	●	
Switchgear control and monitoring	6	6	6	6	6	6	
Switchgear monitoring only	2	2	2	2	2	2	
Programmable switchgear interlocking	●	●	●	●	●	●	
Local control on single-line diagram	●	●	●	●	●	●	
Local switchgear control with OPEN/CLOSE keys	●	●	●	●	●	●	
Local/remote function	●	●	●	●	●	●	
Programmable function keys	1	1	1	7	7	7	
Programmable logic	●	●	●	●	●	●	
Advanced logic engine (order option)	●	●	●	●	●	●	
Measurement functions	P5V20 VT variant	P5U20 CT variant	P5U20 LPCT/LPVT	P5F30 CT/VT variant LPCT/LPVT variant	P5M30 CT/VT variant LPCT/LPVT variant	P5T30 CT/VT variant	
RMS current values		●	●	●	●	●	
RMS voltage values	●		●	●	●	● ²	
RMS active, reactive and apparent power			●	●	●		
Frequency	●	●	●	●	●	●	
Fundamental frequency current values		●	●	●	●	●	
Fundamental frequency voltage values	●		●	●	●	● ²	
Fundamental frequency active, reactive and apparent power values			●	●	●		
Power factor			●	●	●		
Phase differential currents						●	
Phase bias currents						●	
Motor speed detection ⁽¹⁾		●	●		●		
Energy values: active and reactive			●	●	●		
Demand values: phase currents		●	●	●	●	●	
Demand values: active, reactive, apparent power and power factor			●	●	●		
Maximum demand values: phase currents		●	●	●	●	●	
Minimum and maximum demand values: RMS phase currents		●	●	●	●	●	
Minimum and maximum demand values: active, reactive, apparent power and power factor			●	●	●		
Maximum demand values over the last 31 days and 12 months: active, reactive, apparent power			●	●	●		
Minimum demand values over the last 31 days and 12 months: active, reactive power			●	●	●		
Maximum and minimum values: currents		●	●	●	●	●	
Maximum and minimum values: voltages	●		●	●	●	● ²	
Maximum and minimum: frequency	●	●	●	●	●		
Maximum and minimum: active, reactive, apparent power and power factor			●	●	●		
Harmonic values of phase current and THD		●	●	●	●	●	
Harmonic values of voltage and THD	●		●	●	●	● ²	
Voltage sags and swells	●		●	●	●		
Logs and records	P5V20 VT variant	P5U20 CT variant	P5U20 LPCT/LPVT	P5F30 CT/VT variant LPCT/LPVT variant	P5M30 CT/VT variant LPCT/LPVT variant	P5T30 CT/VT variant	
Sequence of event record	●	●	●	●	●	●	
Last fault record	●	●	●	●	●	●	
Disturbance record	●	●	●	●	●	●	
Tripping context record	●	●	●	●	●	●	
Relay maintenance data log	●	●	●	●	●	●	
Security data log	●	●	●	●	●	●	
Monitoring functions	ANSI code	P5V20 VT variant	P5U20 CT variant	P5U20 LPCT/LPVT	P5F30 CT/VT variant LPCT/LPVT variant	P5M30 CT/VT variant LPCT/LPVT variant	P5T30 CT/VT variant
Trip circuit supervision	74	1	1	1	1	1	2
Circuit breaker monitoring		1	1	1	1	1	1
Relay monitoring		●	●	●	●	●	●

(1) Function available if 12DI / 4DO board is present (2) For 1 voltage channel

Outgoing protection

- Feeder overcurrent protection
- Feeder overload protection

Feeder protection

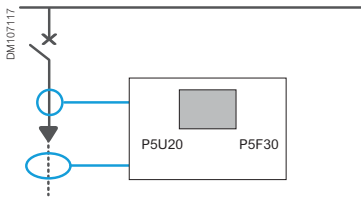

- Feeder earth/ground fault overcurrent

Overhead line protection

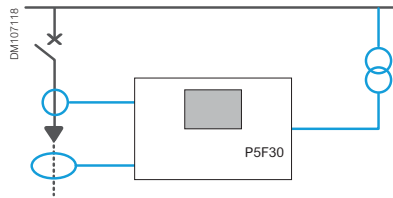

- Directional phase and earth/ground fault overcurrent
- Recloser
- Fault locator

Protection of feeders with metering

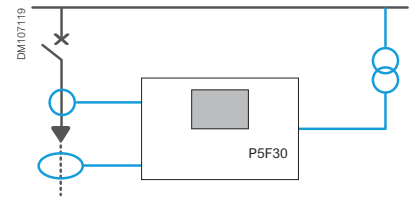

- Power and energy measurement
- Min and max demand values over the last 31 days and 12 months

Incomer protection

- Busbar overcurrent protection

Incomer protection without voltage monitoring

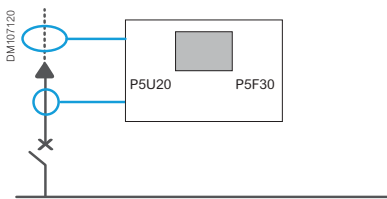

- Earth/ground fault overcurrent

Incomer protection with voltage and frequency monitoring

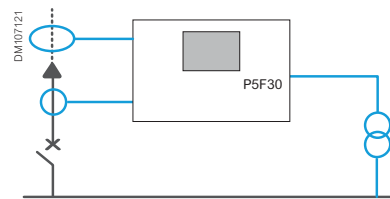

- Under/over voltage
- Frequency, rate of change of frequency

Incomer protection with power quality monitoring

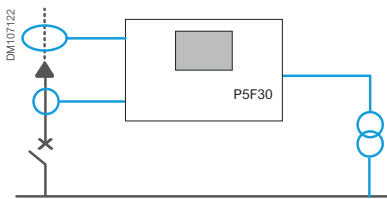

- Voltage and frequency min and max values
- Voltage harmonic values and THD
- Voltage sags and swells

Parallel incomer protection

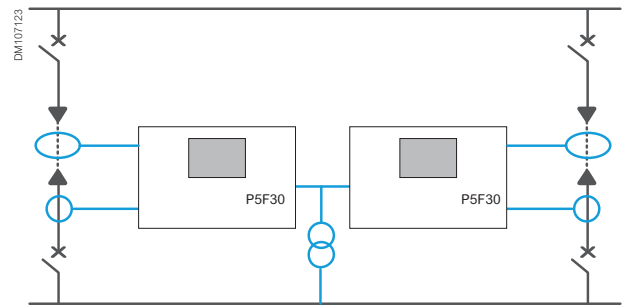

- Directional phase overcurrent
- Directional earth/ground fault overcurrent

Feeder/Incomer application

Voltage monitoring

- Under/over voltage protection
- Earth/ground fault overvoltage
- Under/over frequency protection

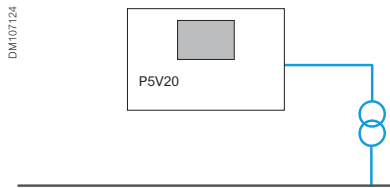

- Load-shedding-specific function: rate of change of frequency

Motor application

Motor protection

- Motor overcurrent and earth/ground fault overcurrent
- Thermal overload
- Motor start-up supervision
- Motor restart inhibition

Motor protection without voltage monitoring

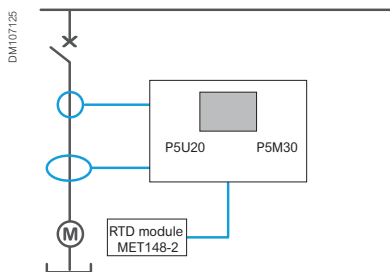

- Temperature measurement (stator, bearings)

Motor protection with voltage monitoring

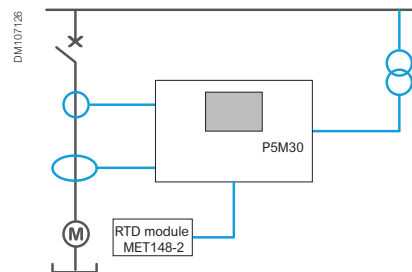

- Undervoltage protection

Transformer feeder protection

- Transformer overcurrent and earth/ground fault overcurrent protection
- Transformer differential protection
- Thermal overload protection
- External trip from thermostat/Buchholz

Transformer feeder protection without voltage monitoring

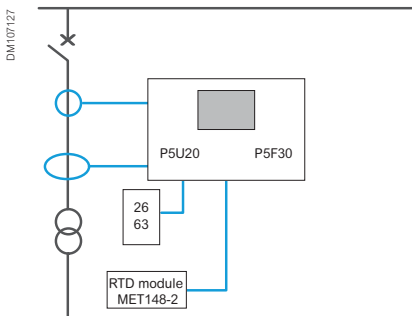

- Temperature measurement (ambient, oil)

Transformer feeder protection with voltage monitoring

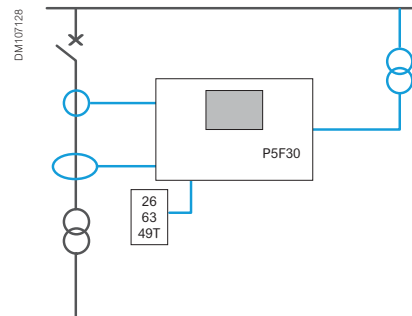

- Over and undervoltage protection

Transformer feeder protection with additional current measurement

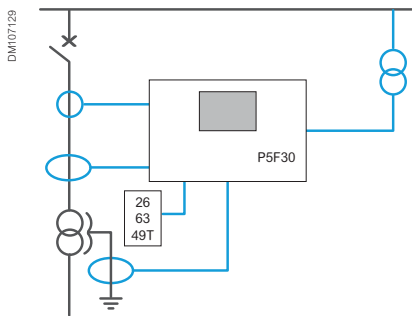

- Tank earth/ground leakage protection

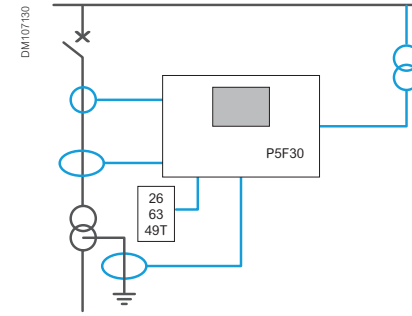

- Earth/ground fault overcurrent on the secondary side

Transformer feeder protection with differential function

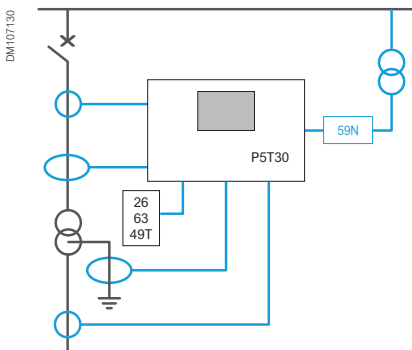

- Differential protection
- Restricted earth-fault protection

Transformer in-come protection

- Busbar overcurrent protection
- Inter-trip from primary circuit breaker protection

Transformer in-come protection without voltage monitoring

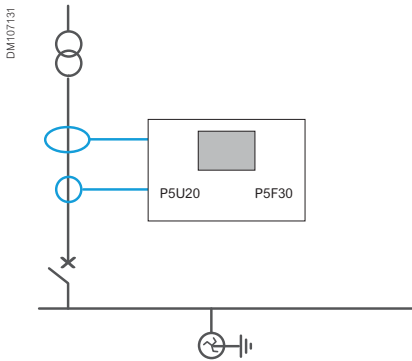

- Transformer earth/ground fault overcurrent

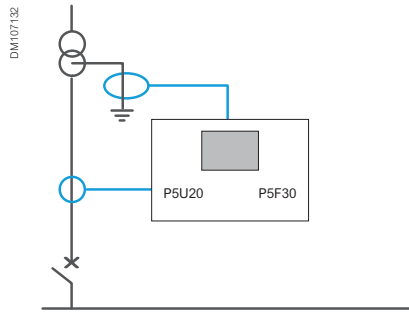

- Earth/ground overcurrent for transformer and back-up protection

Transformer in-come protection with voltage monitoring

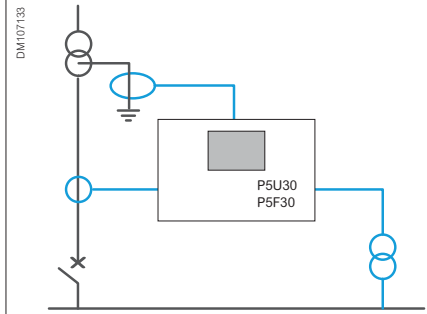

- Over and undervoltage protection
- Restricted earth/ground fault protection
- Power and energy measurement
- Min and max demand values over the last 31 days and 12 months

Parallel transformer in-come protection

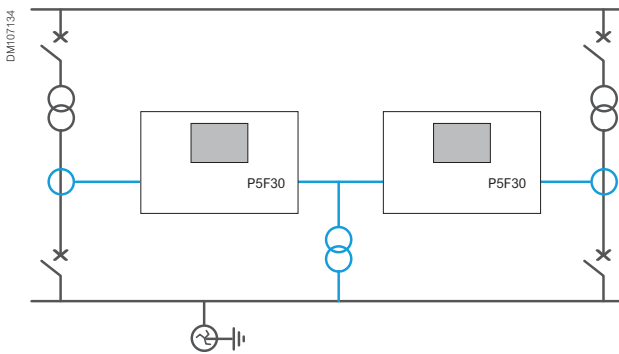

- Directional phase overcurrent

Transformer in-come protection with differential function

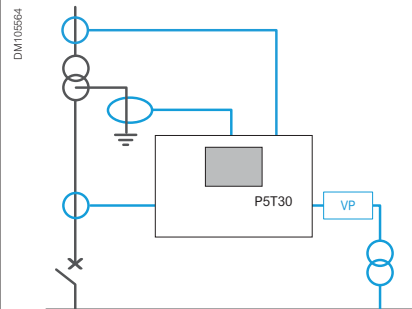

- Transformer differential
- Restricted earth-fault
- Overfluxing protection

Busbar arc-flash protection

- Arc-flash protection, activated by overcurrent and light signals, or light signals alone

Centralized busbar arc-flash protection

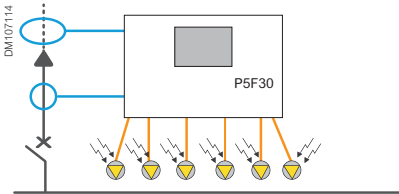

- Up to 6 light point sensors to monitor the busbar

De-centralized busbar arc-flash protection

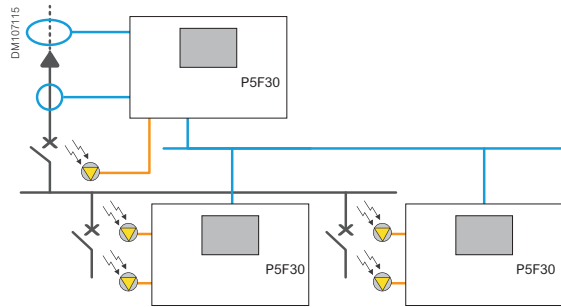

- Up to 6 light point sensors in each relay
- Transmission of light detection signals via digital I/O or IEC 61850 GOOSE messages

Zone arc-flash protection

- Up to 8 arc-flash protection stages in each device (P5x30)
- Transmission of signals via digital I/O or IEC 61850 GOOSE messages

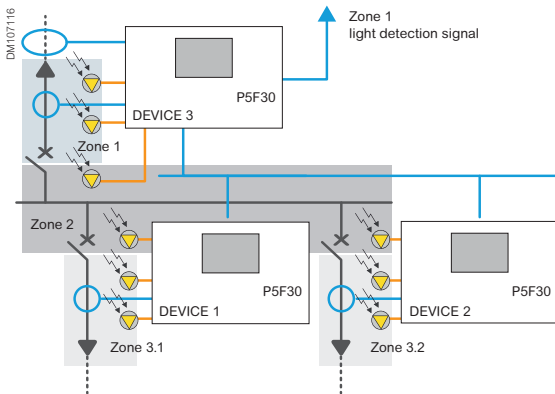

In this application example, the arc-flash sensor for zone 3.1 is connected to Device 1. If the arc-flash sensor detects light and simultaneously Device 3 detects and sends an overcurrent condition, the zone 3.1 is isolated by the outgoing feeder breaker.

The arc-flash sensor for zone 3.2 is connected to Device 2 and operates the same way.

The arc-flash sensors for zone 2 are connected to Device 1, 2, or 3. If a sensor detects a flash in zone 3, the light-only signal is transferred to Device 3, which then trips the main circuit breaker.

An eventual arc-flash fault in zone 1 does not necessarily activate the current element in Device 3. However, arc-flash detection can be achieved by using the light-only principle. If an arc-flash occurs in the cable termination of zone 1, an inter-trip signal is sent by Device 3 to the upstream circuit breaker.

Capacitor bank protection

- Overcurrent and earth/ground fault protection
- Overload protection

Capacitor bank protection without voltage monitoring

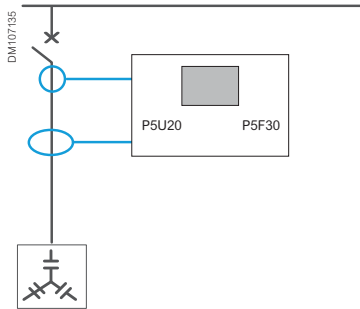

- Capacitor overvoltage protection, based on current measurement and harmonics
- Current harmonic values and THD

Capacitor bank protection with voltage monitoring

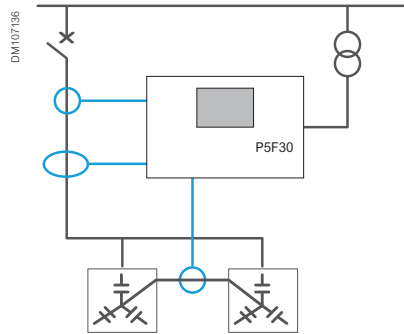

- Capacitor bank unbalance
- Overvoltage
- Current and voltage harmonic values and THD

Protection of harmonic filters

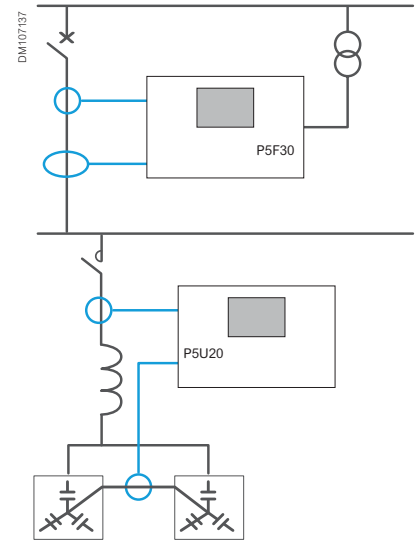

- Overvoltage
- Capacitor bank unbalance
- Capacitor overvoltage protection, based on current measurement and harmonics
- Current harmonic values and THD

Motor overspeed - ANSI 12

The function is based on the direct measurement of motor speed. The overspeed protection function detects racing when the motor is driven by the load, or a loss of synchronization for synchronous motors, or for process monitoring. This function picks up if the speed measured exceeds the speed setting and it will trip after a definite time delay.

- Two stages of overspeed protection with definite time delay
- The function is available when a 12 DI / 4 DO board is present and the motor speed detection function is enabled.

Functions	Settings
Motor speed setting range	100 – 160% Ω_n
Definite time delay	1 s to 300 s

Motor underspeed - ANSI 14

The function is based on the direct measurement of motor speed. The underspeed protection function can detect the slow-down of motor speed after motor starting, possibly resulting from mechanical overloads or locked rotor. This protection is active after the motor speed has successfully achieved the speed setting. The function picks up if the speed measured drops below the speed setting after having first exceeded the set point by 5%. Under-speed protection is blocked when the motor speed drops below 5% of rated motor speed to avoid unwanted tripping when the motor is switched off.

- Two stages of underspeed protection with definite time delay
- The function is available when a 12 DI / 4 DO board is present and the motor speed detection function is enabled.

Functions	Settings
Motor speed setting range	10 – 100% Ω_n
Definite time delay	1 s to 300 s

Motor anti-backspin (ABS)

For a motor with high inertia, once the CB/Contactor supplying power to the motor is switched off, the rotor may continue to turn for a considerable length of time. In that case, the motor terminal voltage is out of phase and the motor re-starting operation may result in catastrophic failure. In some other applications for example when a motor is on a down-hole pump, after the motor stops, the liquid may fall back down the pipe and spin the rotor backwards. It would be very undesirable to start the motor at this time. In these circumstances the anti-backspin function is used to detect when the rotor has completely stopped, to allow re-starting of the motor.

- One stage of anti-backspin protection with definite time delay
- This function is available when Motor Status function is enabled
- 3 different criteria for rotor stop detection
- Depending on criteria selected, a 12 DI / 4 DO board and the motor speed detection function may be required.

Functions	Settings
Rotor stop detection mode	Zero speed, Zero speed switch, Motor stopped
Definite time delay	1 s to 7 200 s

Fault locator - ANSI 21FL

The function can be used to locate a short-circuit fault and an earth/ground fault in radially operated networks. The fault location is given as reactance (Ohms) and as distance in kilometers or miles. The fault value can then be exported, for example, with an event to a Distribution Management System (DMS). The system can then locate the fault. If a DMS is not available, the distance to the fault is displayed as kilometers and as a reactance value.

Functions	Settings
Pick-up	0.10 - 5.00 pu
Line reactance	0.010 to 10.000 Ohm/km
Earth/ground factor	0.000 to 10.000
Earth/ground factor angle	-60° to +60°

Neutral admittance - ANSI 21YN

The neutral admittance protection function can be applied in high resistance earthed, unearthed or compensated power systems to detect earth fault with increased sensitivity. The neutral admittance Y_n is calculated based on the zero-sequence current I_N and the zero-sequence voltage V_N .

- Two independent stages with definite time delay.
- Each stage settable for over-admittance or over-conductance or over-susceptance.
- Four setting groups.

Functions	Settings
Pick-up for Y_n	1% - 200% I_N/V_N for current measured with very sensitive earth/ground fault CT
	5% - 1000% I_N/V_N for current measured by standard earth/ground fault CTs
	25% - 5000% I_N/V_N for current measured by CSH and for calculated I_N
Pick-up for G_n	1% - 100% I_N/V_N for current measured with very sensitive earth/ground fault CT
	5% - 500% I_N/V_N for current measured by standard earth/ground fault CTs
	25% - 2500% I_N/V_N for current measured by CSH and for calculated I_N
Pick-up for B_n	1% - 100% I_N/V_N for current measured with very sensitive earth/ground fault CT
	5% - 500% I_N/V_N for current measured by standard earth/ground fault CTs
	25% - 2500% I_N/V_N for current measured by CSH and for calculated I_N
Directional mode	Non-directional, Forward, Reverse
Operation delay	0.00 to 300 s
Reset time	0 to 100 s
SOL ⁽¹⁾ operation	Disable/Enable
SOL ⁽¹⁾ operation delay	0.05 to 300 s

(1) SOL = Selective Overcurrent Logic

Overfluxing - ANSI 24

The transformer overfluxing protection detects an inadmissibly high induction in the iron core of transformers which may have been caused by a voltage increase and/or a frequency decrease. This protection function is available in P5T30 when voltage connection mode is VP or VPP. The element measures the ratio of voltage to frequency (Volts per Hertz) and operates when this ratio exceeds the setting. When the flux level drops below the reset value, the reset time starts..

- One stage with definite time delay for alarm purposes
- Two stages for tripping purposes incl. one with inverse time delay
- Four setting groups

Functions		Settings
V/f>1 alarm stage	Pick-up	1.00 - 1.60
Operate delay		0.00 - 10000.00 s
V/f>1 trip stage	Pick-up	1.05 - 1.60
Operate curve		DT, Prg1, Prg2, Prg3
Operate delay		0.00 - 10000.00 s
V/f>2 trip stage	Pick-up	1.05 - 1.60
Operate delay		0.00 - 10000.00 s

Synchro-check - ANSI 25

This function checks the phase to phase voltages on both sides of a circuit breaker (CB) and allows CB closing when the voltage phase angle, magnitude, frequency differences are all within permitted limits.

- Seven operation modes of no-voltage conditions are provided (dead line, dead bus).
- Synchronous mode is provided, where the frequency difference is less than 0.3 Hz.
- Asynchronous mode is provided, where CB close time is compensated.
- Independent settings for voltage phase angle, magnitude, frequency differences.
- Four setting groups.

Functions	Settings
Synchronization mode	Off, Asynchronous, Synchronous
Voltage check mode	DD, DL, LD, DD/DL, DD/LD, DL/LD, DD/DL/LD ⁽¹⁾
Circuit breaker close time	0.04 to 0.60 s
Dead line voltage setting limit	0.01 - 1.20 pu
Active line voltage setting limit	0.10 - 1.30 pu
Frequency difference	0.01 - 1.0 Hz
Voltage difference	0.01 - 0.60 pu
Phase angle difference	2° - 90°
Request timeout	0.1 to 600 s

(1) D = no-voltage condition, L = voltage condition

Under voltage - ANSI 27

The Undervoltage protection function (ANSI code 27) is used to detect voltage dips or sense abnormally low voltages to trip, trig load shedding or load transfer. The function provides the selection of three phase-to-phase voltages or three phase-to-ground voltages for comparison with the voltage threshold. Each phase can start or trip independently. If the fault situation remains longer than the protection operate time setting, a trip signal is issued.

- Three independent stages with the same settings and performance
- Blocking during voltage transformer fuse failure
- Apply programmable curves and adapt operation to the low voltage ride through capability of the generator
- Four setting groups for each stage

Functions		Settings
Measurement mode		Phase-Phase; Phase-Ground
Tripping logic		Any Phase; Three Phase
V<1 ... V<3 stages	Pick-up	0.02 - 1.20 pu
Delay type		DT, IDMT, Prg1-3: 3 programmable curves with 16 setting points
Definite time delay		0.00 - 600.00 s
Reset delay		0.00 - 100.00 s
Hysteresis		1 - 5%
CB open blocking		Off/On

Positive sequence under voltage - ANSI 27P

This function is applied to detect insufficient or unbalanced system voltages and detect reverse rotation.

- Two independent stages with definite time are provided.
- Low voltage self-blocking will operate when the maximum phase to phase voltage is less than 10% V_n .

Functions		Settings
Pick-up		0.20 - 1.20 pu
Time delay		0.00 - 300.00 s
Low voltage self-blocking		0.02 - 1.00 pu

Directional active underpower - ANSI 32P

This function can be used as underpower protection (e.g. loss of load of a motor) or as reverse power protection (e.g. power generation by a motor if supply is disconnected). It starts if measured active power drops below the set threshold and operates with definite time delay.

- Two independent stages with definite time delay are provided
- Undervoltage blocking if the maximum phase to phase voltage is less than 5% U_n .
- Four setting groups for each stage.

Functions		Settings
Pick-up		-200 % to 200 % $S_n^{(1)}$ with $S_n = \sqrt{3} U_n I_n$
Time delay		0.0 to 300.00 s

Wattmetric earth/ground fault - ANSI 32N

This function detects single phase to earth/ground faults in Petersen coil compensated power systems. It operates on active residual power. Using memory mode also allows operation on intermittent earth/ground faults.

- Neutral displacement voltage VN> element to enable function.
- Settable forward/reverse direction.
- Operating characteristic with settable minimum active power and sector angles.
- Dedicated blocking input.
- Dedicated input to bypass operate time delay.
- Four setting groups for each stage.

Functions	Settings
Direction mode	Reverse, forward
Setting range	0.1 % to 20 % Sn
Time delay	0.00 to 300.00 s
VN pick-up	0.020 - 0.800 pu
Sector angle	0° - 90°
Memory mode	None, voltage, time, voltage+time
Memory hold time	0.05 to 10.00 s
Memory operating time	0.00 to 100.00 s
SOL ⁽¹⁾ operation	mode Off, SOL1, SOL2

Phase undercurrent - ANSI 37

This function is typically used to detect defects in motor drives based on loss of load detection due to a significant drop of current. It measures the fundamental component of the phase currents.

- One stage with definite time delay is provided.
- Settable low current self-blocking parameter.
- Four setting groups.

Functions	Settings
Pick-up	0.05 - 1.00 pu
Low current blocking	0.02 - 0.50 pu
Time delay	0.00 - 300.00 s

(1) SOL = Selective Overcurrent Logic

Temperature monitoring - ANSI 38

This function is used to detect abnormal heat rise by directly measuring the temperature inside equipment (transformer, motors, generators, ...) with RTD thermal sensors such as Pt100, Ni100 or Ni120.

- Two independent set points: alarm and tripping for each RTD sensor.
- Inbuilt RTD supervision (shorting, open loop).

Functions	Settings
Pick-up	0 to 180 °C (32 at 356 °F)
Time delay	0.00 to 600.0 s

Negative sequence overcurrent - ANSI 46

This function provides greater sensitivity to detect phase to phase faults at the end of long lines or behind transformers. It can also be used for machine application against temperature rise caused by unbalanced power supplies, phase inversion, or loss of phase.

- Two stages with definite time or inverse time delayInbuilt RTD supervision (shorting, open loop)
- Definite-time adder and minimum operating time functions in IDMT mode
- Four setting groups for each stage

Functions	Settings
Pick-up	0.02 - 5.00 pu
Definite time delay	0.00 - 300.00 s
Inverse time delay curves	IEC: SI, VI, EI, LTI, UTI
	IEEE: MI, VI, EI
	ANSI: NI, STI, LTI
	Others: UK Rectifier, FR_STI, RI, CO2, CO5, CO7, CO8, CO9, CO11, BPN
	Prg1-3: 3 programmable curves with 16 setting points
Reset curve	DT, IDMT, Prg1-3
Reset delay	0.00 - 100.00 s
DT adder	0.00 - 1.00 s
Minimum operate delay	0.00 - 10.00 s

Unbalanced overcurrent, broken conductor - ANSI 46BC

This function is applied to detect broken conductor conditions, based on the ratio between the negative sequence current and positive sequence current.

- Two stages with definite time delay are provided.
- This function is not available in 2CT mode.
- Four setting groups.

Functions	Settings
Pick-up	2 to 70 %
Time delay	0.00 s to 300 s

Negative sequence overvoltage - ANSI 47

Protection of a rotating machine from being energized with a reverse voltage sequence or prevention of overheating of the motor due to a broken conductor condition. It monitors the voltage phase sequence detecting a reverse rotation or voltage unbalance due to a missing (asymmetrical) phase. The detection of these conditions can then be used to trip the machine to prevent damage to both motor and any mechanically coupled processes.

- Two independent stages with definite or inverse time delay.
- When the VT connection is configured to VPP/VPPy the function is automatically disabled.
- Four setting groups for each stage.

Functions	Settings
Pick-up value	0.01 - 1.00 pu
Delay type	Definite time (DT), inverse time (INV)
Time delay	0.00 s to 300 s
Reset time	0.03 s to 300 s

Motor start-up supervision - ANSI 48

Protection of motors against overheating caused by excessive start time due to heavy motor load or too low voltage.

- Motor start detection is based on circuit breaker (CB) position and current.
- Operation with definite time delay or inverse time delay.

Functions	Settings
Motor start detection current	1.50 - 10.00 pu
Motor start detection mode	CB position, current, CB position and current
Delay type	Definite time (DT), inverse time (INV)
Motor start time	1 s to 300.0 s

Thermal overload protection for feeders - ANSI 49F

This function is applied to detect conditions where thermal damage may be caused by overloads on cables. The thermal capacity is calculated by the thermal replica according to IEC60255-149. The equivalent current for the thermal replica is the maximum RMS current of 3 phases.

- Independent settable alarm stage and trip stage are provided.
- Current based setting mode and temperature based setting mode are provided.
- Temperature sensor can be applied for ambient temperature based mode.
- A digital input can be applied to inhibit the thermal overload protection
- Four setting groups are provided.

Functions	Settings
Basic current setting	0.10 to 4.00 pu
k factor	0.10 to 1.50
Heating time constant	1.0 min to 1000 min
Thermal alarm value	50 % to 100 %
Reserve time thermal alarm	1.0 min to 1000 min
Temperature based mode	Current, Ambient
Nominal ambient temperature	-40 °C to 300 °C
Max object temperature	-40 °C to 300 °C
Alarm object temperature	0 °C to 300 °C
Min object temperature	-40 °C to 300 °C
Default object temperature	-40 °C to 300 °C
Thermal level initiation	0 to 90%

Thermal overload protection for motor - ANSI 49M

This function is applied to detect conditions where thermal damage may be caused by overloads on motors or cables. The thermal capacity is calculated by the thermal replica according to IEC 60255-149. The equivalent current for the thermal replica considers the maximum RMS current of 3 phases and the negative phase sequence current with a settable weighting coefficient.

- Independent settable alarm stage and trip stage are provided.
- Current based setting mode and temperature based setting mode are provided.
- Temperature sensor can be applied for ambient temperature based mode.
- A digital input can be applied to inhibit the thermal overload protection
- Four setting groups.

Functions	Settings
Basic current setting	0.1 to 4.0 pu
k factor	1.0 to 1.5
Heating time constant	1.0 min to 1000 min
Time constant for motor start	1.0 min to 1000 min
Cooling time constant	1.0 min to 1000 min
Thermal alarm value	50% to 100%
Reserve time thermal alarm	1.0 min to 1000 min
Temperature based mode	Current, Ambient temperature
Nominal ambient temperature	-40 °C to 300 °C
Max object temperature	-40 °C to 300 °C
Alarm object temperature	0 °C to 300 °C
Min object temperature	-40 °C to 300 °C
Default object temperature	-40 °C to 300 °C
Thermal level initiation	0 to 90%
Unbalance factor	0 to 10

Arc-flash - ANSI 50ARC

This function is used to detect and minimize the effects of an internal arcing fault, commonly by tripping the CB faster than conventional protection to mitigate the fault.

- Eight independent arc-flash stages.
- GOOSE communication to share informations between two PowerLogic P5 relays.
- Three to six arc-flash sensors available.
- Trip in 4 ms maximum if light detection only.
- Trip in 15 ms maximum if light detection and overcurrent conditions detected with GOOSE communication between two PowerLogic P5 relays.

Functions	Settings
Arc-flash stage 1 to 8	On, Off
Detection mode	Light, light + current
Pick-up phase current	0.50 to 8.00 pu
Pick-up ground/earth current	0.10 to 5.00 pu
Trip delay	0 ms to 255 ms
Hold time	20 ms to 2500 ms

Breaker failure - ANSI 50BF

The circuit breaker failure function (CBF) can be used to operate any upstream circuit breaker (CB) if the programmed output signals, to the main breaker, have not disappeared within a given time after the initial command.

- Two circuit breaker controls are available.

Functions	Settings
Phase current pick-up	0.02 to 4.00 pu
Earth/ground current pick-up	0.02 to 4.00 pu with 1/5 A standard CT
	0.05 to 4.00 pu with CSH core balance CT
Very sensitive earth/ground current pick-up	0.002 to 0.800 pu
Time delay	0.00 s to 50.00 s

Switch onto fault (SOTF) - ANSI 50HS

This function is applied to provide fast tripping based on instantaneous overcurrent protection, when the CB is closed onto a faulted line.

- One stage instantaneous overcurrent is provided.
- CB open/dead line detection is based on a low current threshold 0.02 In or digital input.
- SOTF active duration after CB closure is settable.

Functions	Settings
Pick-up	1.0 to 40.0 pu
Dead line detection delay	0 to 60.0 s
SOTF active time	0.1 to 60.0 s

Voltage controlled overcurrent - ANSI 51V

Voltage-controlled overcurrent protection can be used as system back-up protection or as transformer back-up protection. Normally voltage-controlled overcurrent protection is preferred for the applications where a generator is directly connected to a busbar without a step-up transformer. It is recommended to use this solution to increase the sensitivity of overcurrent back-up transformer protection. PowerLogic P5 relays provide a dynamic setting mode for each overcurrent protection stage, so that the overcurrent pick-up setting and the operate delay setting will be replaced by dynamic threshold and dynamic operate delay settings. Thanks to this, the overcurrent protection adjusts the current setting according to the detected undervoltage condition. The information about application and setting examples can be found in the P5 Application Book at se.com

Cold Load Pick-up (CLP)

This function helps avoid unwanted tripping of overcurrent protection elements (50/51, 50N/51N, 50G/51G and 67) during energisation after long periods of outage. Depending on installation characteristics such operations can generate inrush currents that can exceed the pick-up level of protection. These inrush currents may be caused by:

- Magnetizing currents of power transformers.
- Motor starting currents.
- Simultaneous re-energization of the entire facility load (air conditioning, heating...).

In principle the protection settings should be defined in order to avoid tripping on such inrush currents. However if the settings result in insufficient sensitivity levels or too long delays, the CLP function can be used to temporarily increase or inhibit thresholds after re-energization.

Functions	Settings
Idle current	0.01 - 0.50 pu
Pick-up	0.30 - 10.00 pu
Dead time	0.10 - 14400.00 s
Definite time delay	0.01 - 300.00 s

Non-directional/directional phase overcurrent - ANSI 50/51/67

The overcurrent protection function is used against short circuit faults and heavy overloads. It provides six stages with definite or inverse operate time delay. Each of the stages can be selected non-directional, directional forward or directional reverse. Phase segregated start and trip signals are available for every overcurrent stage. Typical applications are: short-circuit protection of two parallel cables or overhead lines in a radial network, short-circuit protection of a looped network with a single feeding point or short-circuit protection of a two-way feeder, which usually supplies loads but is used in special cases as an incoming feeder.

- Six (6) independent stages with the same settings and performance
- Selective overcurrent logic (SOL1, SOL2) function
- Inrush blocking (68H2) function for each stage
- Definite-time adder and minimum operating time functions in IDMT mode
- Dynamic mode allowing to adjust overcurrent protection settings during transient period. Cold load pick-up (CLPU) or voltage-controlled overcurrent protection can be realized.
- Four setting groups for each stage

Functions		Settings
Direction mode		Non-directional; Forward; Reverse
I>1 ... I>6 stages	Pick-up	0.05 - 40.00 pu (DT) 0.05 - 5.00 pu (IDMT)
Definite time delay		0.00 - 600.00 s
Inverse time delay curves		IEC: SI, VI, EI, LTI, UTI IEEE: MI, VI, EI ANSI: NI, STI, LTI Others: UK Rectifier, FR_STI, RI, CO2, CO5, CO7, CO8, CO9, CO11, BPN Prg1-3: 3 programmable curves with 16 setting points
Reset curve		DT, IDMT, Prg1-3
Reset delay		0.00 - 100.00 s
DT adder		0.00 - 1.00 s
Minimum operate delay		0.00 - 10.00 s
Characteristic angle		-95° - +95°
VTS blocking		Blocked; Non-directional
Tripping logic		1 out of 3, 2 out of 3
Inrush blocking		Off/On
Selective overcurrent logic		Off, SOL1, SOL2
Dynamic mode		Off/On

Non-directional/directional phase overcurrent - ANSI 50N/51N/50G/51G/67N

This protection element is used against phase to earth/ground faults in all types of networks. It provides six stages with definite or inverse operate time delay.

Each of the stages can be selected non-directional, directional forward or directional reverse. Depending on the selection at ordering stage PowerLogic P5 offers two variants of analogue modules: standard module with 1A/5A and very sensitive 1A neutral inputs, or a module with one input for the cooperation with CSH core balance CT.

- Six (6) independent stages with the same settings and performance
- Selective overcurrent logic (SOL1, SOL2) functions and VTS blocking
- Definite-time adder and minimum operating time functions in IDMT mode
- Dynamic mode allowing to adjust earth/ground fault protection settings during transient period, for example Cold Load Pick-up.
- Four setting groups for each stage

Functions		Settings			
Neutral current input		Measured with 1 A/5 A CT			
		Measured with 1 CSH core balance CT			
		Calculated with the sum of the 3 phase currents			
		Measured with 1 A CT			
		Measured 1A/5A CT	Measured CSH	Calculated	Measured very sensitive
IN>1 ... IN>6 stages	DT pick-up	0.02 - 20.00 pu	0.05 - 20.00 pu	0.05 - 40.00 pu	0.002 - 1.000 pu
	IDMT pick-up	0.02 - 5.00 pu	0.02 - 5.00 pu	0.05 - 5.00 pu	0.002 - 1.000 pu
VN Pick-up value		0.01 - 1.00 pu			
Pick-up sector size		10° - 170°			
Definite time delay		0.00 - 300.00 s			
Inverse time delay curves		IEC: SI, VI, EI, LTI, UTI			
		IEEE: MI, VI, EI			
		ANSI: NI, STI, LTI			
		Others: UK Rectifier, FR_STI, RI, CO2, CO5, CO7, CO8, CO9, CO11, BPN			
		Prg1-3: 3 programmable curves with 16 setting points			
Reset curve		DT, IDMT, Prg1-3			
Reset delay		0.00 - 100.00 s			
DT adder		0.00 - 1.00 s			
Minimum operate delay		0.00 - 10.00 s			
Angle offset		-180° - +180°			
VTS blocking		Blocked; Non-directional			
Selective overcurrent logic		Off, SOL1, SOL2			
Dynamic mode		Off/On			

(*) CSH current input is an ordering option.

Capacitor bank unbalance - ANSI 51C

This function is used in double-wye-connected capacitor banks. The unbalance current is measured with a dedicated current transformer (i.e. 5A/5A) between two starpoints of the bank.

- Two stages with definite time delay.
- Unbalance current measured with standard earth/ground fault CT or CSH core balance CT.
- Four setting groups for each stage.

Functions	Settings
Pick-up	0.02 to 20.00 pu for standard CT
	0.05 to 20.00 pu for CSH core balance CT
Time delay	0.00 to 300 s

Locked rotor - ANSI 51LR

Protection of motors against overheating caused by motor rotor jam due to heavy motor load or a mechanical failure after the normal start.

- Operation with definite time delay or inverse time delay.
- Automatically blocked when the motor is starting.

Functions	Settings
Pick-up	10 to 100.0 % IStart
Time delay	1 to 300.0 s
Time delay type	Definite time (DT), Inverse time (INV)

Overvoltage - ANSI 59

The Overvoltage protection function (ANSI code 59) is used to detect system voltages that are too high or to check that there is sufficient voltage to authorise a source transfer. The function provides the selection of three phase-to-phase voltages or three phase-to-ground voltages for comparison with the voltage threshold. Each phase can start or trip independently. If the fault situation remains longer than the protection operate time setting, a trip signal is issued.

- Three independent stages with the same settings and performance.
- Four setting groups for each stage.

Functions	Settings
Measurement mode	Phase-Phase; Phase-Ground
Tripping logic	Any Phase; Three Phase
V>1 ... V>3 stages	Pick-up 0.02 - 1.50 pu
Delay type	DT, IDMT, Prg1-3: 3 programmable curves with 16 setting points
Definite time delay	0.00 - 600.00 s
Reset delay	0.00 - 100.00 s
Hysteresis	1 - 5%
CB open blocking	Off/On

Capacitor overvoltage - ANSI 59C

This function calculates the voltages of a three-phase Y-connected capacitor bank using the measured currents of the capacitors. No voltage measurements are needed. Especially used in filter applications, harmonics are present, which depending on phase angles, can increase the peak voltage. This protection function calculates the worst-case overvoltage in per-unit values using Equation 7.10 according to IEC 60871-1 standard. Harmonics up to 15th are taken into account.

- Three independent stages with define time.
- Four setting groups.

Functions	Settings
Pick-up setting UC>	0.10 to 2.50 UCLN
Time delay	1.0 to 30.0 s
Rated L-N voltage UCLN	100 to 260 000 V
Capacitance per phase	1.00 to 650.00 μF

Neutral voltage displacement - ANSI 59N

This function is used for general earth/ground fault detection and for backup protection (unselective). It measures the fundamental component of the neutral displacement voltage.

- 3 stages with DT operating time
- Attenuation of the third harmonic by more than 60 dB
- 4 setting groups for each stage.

Function	Settings
Pick-up	0.02 to 1.50 pu
Time delay	0.00 s to 300.00 s

Low impedance restricted earth/ground fault - ANSI 64REF

The Restricted Earth/Ground Fault protection element is mainly used as a unit protection for two-winding transformers, generators and motors in order to detect ground-faults more sensitively than overall machine differential protection is able to do. This protection element is based on the principle of differential protection, it compares phase and starpoint currents. It provides selectivity, with boundaries of the protected zone given from the CT locations.

- Operation characteristic with biasing from residual or maximum phase current.
- Unrestrained operation with high set threshold.
- Optional blocking or restraining from CT supervision
- Four setting groups.

Function		Settings
Neutral current input		Measured with 1A/5A CT, Measured with very sensitive 1A CT
5 CT application		Off/On
Operating mode		Sum(IP) bias, Max(IP) bias
Low set Is1	Pick-up	0.01 - 1.00 pu
Operate delay		0.00 - 1.00 s
High set mode		Off/On
High set Is2	Pick-up	2.00 - 30.00 pu
Slope k1		0 - 100 %
Low set Ib1		0.10 - 1.50 pu
Slope k2		10 - 200 %
Minimum IG	Pick-up	0.00 - 1.00 pu
CTS operating mode		Indication, Blocking, Restraining
CTS low set Is1	Pick-up	0.01 - 1.00 pu

Motor restart inhibition - ANSI 66

This function prevents too frequent motor starts. Every motor has a restriction on the number of starts within a defined period to avoid thermal overload, mainly inside the rotor. A settable time interval between two consecutive starts is also necessary to allow the motor to cool down following the previous start.

- Settable number of starts per hour.
- Settable minimum time between consecutive starts.

Functions	Settings
Time from motor start	0 min, 120 min
Maximum hot starts / hour	1 to 20
Maximum cold starts / hour	1 to 20
Minimum time between starts	0.0 min to 100.0 min

Transient intermittent earth/ground fault - ANSI 67NI

This function detects short transient intermittent phase to earth/ground faults in compensated networks, which cannot be correctly recognized by steady-state directional earth/ground fault functions using the fundamental frequency components only.

- Neutral displacement voltage VN> element to enable function.
- Settable forward/reverse direction.
- Dedicated blocking input to coordinate with AR.
- Four setting groups.

Functions	Settings
Direction mode	Reverse, Forward
Minimum of number of peaks	1 to 20
VN pick-up	0.01 to 0.60 pu
Time delay	0.00 to 300.00 s
Intermittent time	0.01 to 300.00 s
Reset time	0.06 to 300.00 s

Inrush / 2nd harmonic detection - ANSI 68H2

This function detects inrush current flows that occur when transformers or machines are energized. It may be used to stabilize protection functions (e.g. phase overcurrent, earth/ground fault overcurrent, ...) or even to issue a trip if the inrush condition persists too long.

- Based on proven I_2/I_1 measurement.
- Measurement per phase.

Functions	Settings
Pick-up	10 to 35 %
Max Inrush current	1 to 20.00 pu
Operate mode	Cross block, phase block

5th harmonic detection - ANSI 68H5

This function detects 5th harmonic current flows that occur during overexcitation of transformers. It may be used to stabilize protection functions or even to trip if the condition persists too long.

- Based on proven I_5/I_1 measurement.
- Measurement per phase.

Functions	Settings
Pick-up	10 to 100 %
Time delay	0.00 to 300.00 s

Auto-recloser function - ANSI 79

The auto-recloser (AR) function can be used in feeder protection relays to help protect an overhead line. It limits the interruption of service in case of transient or semi-permanent faults that affect overhead lines. The function uses the object control function to control the CB open/close sequence. All other object control methods are in simultaneous use, including object failure monitoring. If the circuit breaker (CB) control fails or another function controls the CB, the AR sequence stops.

- One to four autorecloser shots.
- Control of one or two circuit breakers.
- Control via binary or virtual inputs (IEC 61850).

Functions	Settings
Enable Auto-Recloser	On; Off with digital input (DI), virtual input (VI), virtual output (VO) or function key
Breaker 1 object	Object 1 to Object 6
Breaker 2 object	Object 1 to Object 6
Auto CB selection	On; Off
Input for CB selection	digital input (DI), virtual input (VI), virtual output (VO) or function key
Reclaim time	0.02 to 3000.00 s
Block by external synchro. check	digital input (DI), virtual input (VI), virtual output (VO) or function key
Shot specific reclaim time	On; Off
Settings per shot	0.01 to 1200.00 s (dead time) 0.02 to 300.00 s (discrimination time)
Additional setting 1 st shot	0.02 to 300.00 s (start delay)

Overfrequency - ANSI 81

Over frequency protection can be used as a back-up for generator overspeeding. It is used as well in load restoration schemes to detect that the power system frequency has recovered sufficiently to allow load which had previously been shed to be reconnected. Whenever the frequency reaches the pick-up value of a particular stage, this stage starts, and a start signal is issued. If the fault remains on longer than the operating delay setting, a trip signal is issued.

- Two independent stages with definite time delay
- Low voltage blocking feature
- Four setting groups for each stage

Functions	Settings
f>1 ... f>2 stages	Pick-up 40.00 - 65.00 Hz
Definite time delay	0.00 - 7200.00 s
Low voltage blocking	0.10 - 1.00 pu

Rate of change of frequency - ANSI 81R/81RF

Frequency deviations result from an imbalance between power generation and power loads. Rate of change of frequency protection helps to protect the system from the consequences of such imbalances mainly through two applications. The first one is low frequency load shedding when the system frequency falls too quickly. This becomes more important as power systems with low inertia generation due to many renewable energy sources are increasing. Another application of RoCoF protection is islanding detection, used to identify islanded generators and initiate any appropriate action. Both applications are critical to the stability of modern power systems and can reduce the risk of equipment damage or a widespread outage.

- Nine independent stages with the same settings and performance.
- The function works as independent RoCoF or frequency supervised RoCoF.
- Alternatively, it can be used as additional stages of under/over frequency protection
- Four setting groups for each stage.

Functions	Settings
Direction mode	Negative, Positive, Either
Operating mode	f + RoCoF, Frequency
Pick-up	0.1 - 10.0 Hz/s
df/dt window	0.05 - 1.00 s
Low voltage blocking	0.10 - 1.00 pu
df/dt blocking	0.10 - 20.00 Hz/s
Frequency threshold	40.00 - 65.00 Hz
Definite time delay	0.00 - 100.00 s

Underfrequency - ANSI 81U

The under frequency protection function is used for detection of an abnormally low frequency compared to the rated frequency to monitor power supply quality. The protection may be used for overall tripping or load shedding. Whenever the frequency reaches the pick-up value of a particular stage, this stage starts, and a start signal is issued. If the fault remains on longer than the operating delay setting, a trip signal is issued.

- Eight independent stages with definite time delay
- Low voltage blocking and large df/dt blocking features
- Four setting groups

Functions	Settings
f<1 ... f<8 stages	Pick-up 40.00 - 65.00 Hz
Definite time delay	0.00 - 7200.00 s
Low voltage blocking	0.10 - 1.00 pu
df/dt blocking	0.10 - 20.00 Hz/s

Lockout - ANSI 86

The lockout feature, also called latching, ensures a manual intervention is needed to reset alarm or tripping conditions. It can be programmed in the output matrix setting view. Any protection stage start or trip, digital input, logic output, alarm and GOOSE signal connected to the following outputs can be latched when required:

- Output contacts.
- LEDs on the local panel.
- Virtual outputs.

High impedance busbar differential - ANSI 87BB

The PowerLogic P5 overcurrent elements I> can be used for high impedance busbar protection based on the high impedance differential protection principle, offering stability for any type of fault occurring outside the protected zone and satisfactory operation speed for faults within the zone. For this application instantaneous operation is commonly applied, which can be obtained in a simple way by selecting definite time delay characteristic with minimum time delay setting. The information about application, calculations, setting examples and recommendations for resistors can be found in the P5 Application Book at se.com.

High impedance restricted earth/ground fault - ANSI 87N

The high impedance protection principle can be applied as differential protection for machines, power transformers and busbar installations. It is offering stability for any type of fault occurring outside the protected zone and satisfactory operation speed for faults within the zone. The PowerLogic P5 protection relays can provide this application. Both the standard neutral overcurrent element and the very sensitive neutral overcurrent elements can be used for high-impedance restricted earth fault (REF) protection when paired with suitable external protection components. The information about the application, setting examples and recommendations for resistors can be found in the P5 Application Book at se.com.

2-winding transformer differential protection - ANSI 87T

This protection element minimizes the time that a fault is present within a transformer so its lifecycle is maximized. It can be used for medium and large sized power transformers, step-up or unit transformers in industrial and utility networks. It offers a protection of the transformer from winding and terminal faults, core faults, overloads and pertaining external faults.

Phase-segregated transformer biased differential protection is provided for high-speed discriminative protection for all fault types on both HV and LV windings. It offers through flowing (fault) current stabilization as well as inrush and overfluxing restraints combined with more sensitive restricted earth/ground fault protection on both sides of the transformer. The scheme can be enhanced by the use of other protective devices associated with the transformer such as the Buchholz, pressure relief and winding temperature devices.

- Adjustable polarities of the CTs and settable phase sequence
- Zero sequence current filtering for both HV and LV sides
- Optional blocking or restraining from CT supervision
- High-set unstrained element
- Four setting groups

Function		Settings
Vector group		0 - 11
Zero-sequence current filtering HV/LV		Off/On
Low set Id1	Pick-up	0.10 - 3.00 pu
Slope 1		10 - 150 %
High set mode		Off/On
Low set Id1	Pick-up	1.00 - 30.00 pu
Ir for start of slope 2		1.00 - 30.00 pu
Slope 2		30 - 150 %
Bias calculation mode		Sum of phasors, Sum of abs
Operate delay		0.00 - 100.00 s
Inrush blocking		5 - 50 %
Inrush cross-block		Off/On
Max inrush Id		2.50 - 30.00 pu
Overflux blocking		5 - 100 %
Overflux cross-block		Off/On
CTS operating mode		Indication, Blocking, Restraining

Programmable stages - ANSI 99

For special applications the user can build their own detection stages by selecting the supervised signal and the comparison mode. This allows the user to trigger an event from a selection of signals and select the type, level and timing to suit the application.

- Eight independent stages with definite time delay.
- Priority selection for fast operation needs.
- Multiple coupling and comparison conditions.
- Four setting groups for each stage.

Functions	Settings
Coupling	Phase currents and earth/ground currents, Simple or composed voltages, Current and voltage distortion values, Direct current or voltage, Inverse current or voltage, Phase and earth/ground effective current
Trip conditions	Under, over, difference, absolute difference
Time delay	0.00 to 300 s

Selective Overcurrent Logic (SOL)

The Selective Overcurrent Logic (SOL) function, can considerably reduce the tripping time of the circuit breakers closest to the source, compared to pure time discrimination, and may be used for logic discrimination in closed ring networks also using directional protection. SOL function is applied to the phase overcurrent, directional phase overcurrent, earth/ground fault overcurrent, very sensitive earth/ground fault overcurrent protection elements, with definite time and inverse time delays.

The selective overcurrent logic allows:

- To send a blocking signal when a fault is detected by overcurrent or earth/ground fault protection elements (ANSI 50/51, 50N/51N, 50G/51G, 67, 32N).
- To receive a blocking signal that inhibits the protection elements.

Circuit Breaker (CB) monitoring

Periodic maintenance of circuit breakers is necessary to ensure that the trip circuit and mechanism operate correctly and that the interrupting capability has not deteriorated due to previous fault interruptions. The PowerLogic P5 protection relay records various statistics related to each circuit breaker operation, allowing an accurate assessment of the circuit breaker condition. Statistics are recorded to allow evaluation of both the electrical wear of the breaker contacts and the mechanical wear of the breaker mechanism.

Following counters are provided:

- Number of all circuit breaker operations.
- Number of circuit breaker operations triggered by protection functions e.g. faults.
- Cumulative broken current.
- Circuit breaker operating times.
- Charging times.
- Number of rack-in and rack-out operations.

This feature, when paired with EcoStruxure Asset Advisor brings a proactive maintenance approach to electrical distribution critical assets, combining newest technologies with Schneider Electric's expertise and services. EcoStruxure Asset Advisor offers the ability to anticipate and address issues before they become critical incidents, mitigating safety risks, avoiding unplanned downtime, operational losses and expensive maintenance interventions.

PowerLogic P5 protection relays offer versatile logic capabilities:

- Matrices and Logic timers
- Programmable logic
- Advanced Logic Engine

Overview

Growing complexity of the distribution grids, more demanding reconfiguration schemes and increasing pressure for simplification of architectures are imposing additional flexibility challenges to protection relays. PowerLogic P5 is well suited to tackle these requirements offering versatile logic capabilities which are maximizing its application flexibility. PowerLogic P5 provides several different programmability features allowing the user to create functionality that is not built into its default functionality. The principle is that the application receives analogue or digital inputs, processes the information to send out analogue or digital outputs.

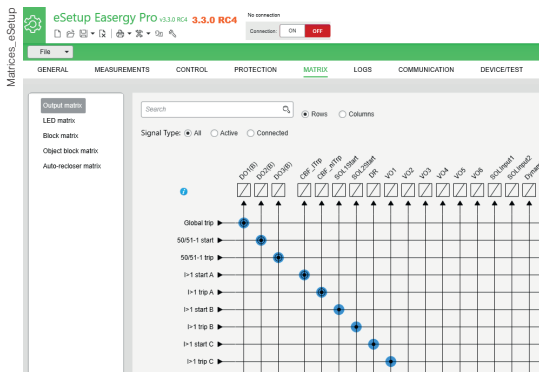

Output matrix view of eSetup Easergy Pro

Matrices

The PowerLogic P5 protection relay provides several matrices that allow to link the hardware and software elements to form protection and control signal chains. This functionality can be used to link different inputs, outputs, statuses and signals allowing activation or blocking other protection elements, control commands, automation functions or recording. Up to 250 GOOSE messages (Network Inputs) can be associated to virtual inputs and thus received for processing.

Calendar and Logic timers

The PowerLogic P5 protection relays offer four settable timers that can be used for the applications that require actions based on calendar time. Logic timer function offers a possibility of assigning freely configurable time schemes to the output signal of each Boolean equation. 13 special logic timers can be configured thru HMI and IEC 61850.

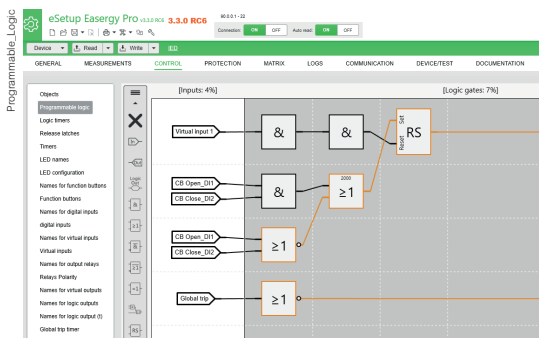

Programmable logic view of eSetup Easergy Pro

Programmable logic

PowerLogic P5 protection relays support user-defined programmable logic for Boolean signals. User-configurable logic can be used to create functionality that is not provided by the protection relay as a default. 128 input logic gates, 50 virtual inputs, 20 virtual outputs and logic timers provide a flexible and easy to use interface optimized for realization of time critical schemes at an execution rate of 10 ms.

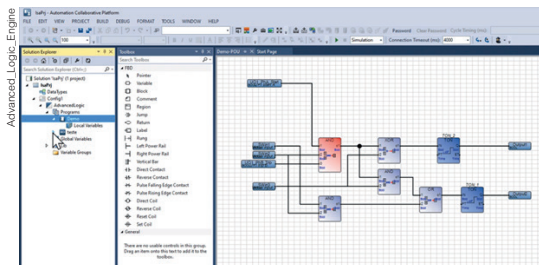

IsaGRAF™ Workbench view of Rockwell Automation

Advanced Logic Engine

In addition to the above "Programmable Logic" PowerLogic P5 protection relays can be equipped with Advanced Logic based on IsaGRAF™ Runtime. With this optional device feature the user is able to define his programmable logic using the environment of the IsaGRAF™ Workbench software tool of Rockwell Automation. Advanced Logic can be used in conjunction with the programmable logic to create a very flexible and strong logic capability. The Advanced Logic is optimized for configuring very flexible but less time demanding application functions such as complex control schemes like Automatic Transfer Switch (ATS). The Advanced logic is compliant to the IEC 61131 and IEC 61499 standards supporting FBD, SFC, ST, LD, SAMA programming languages. This approach maximizes flexibility and interoperability with well recognized automation software technology at an execution rate of 40 ms.

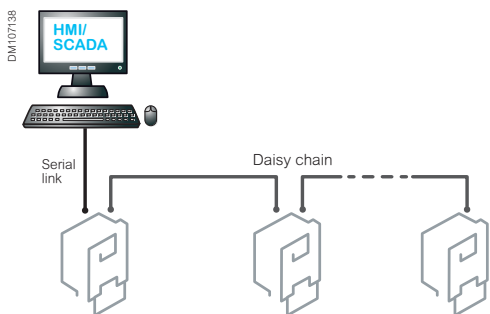

Connection to SCADA using serial line

This architecture allows you to connect HMI/SCADA to a set of PowerLogic P5 protection relays using a multi-drop serial communication link with master-slave communication.

Available protocols:

- Modbus RTU
- IEC 60870-5-101
- IEC 60870-5-103
- DNP3

Time synchronization protocol:

- IRIG-B
- Minute pulse

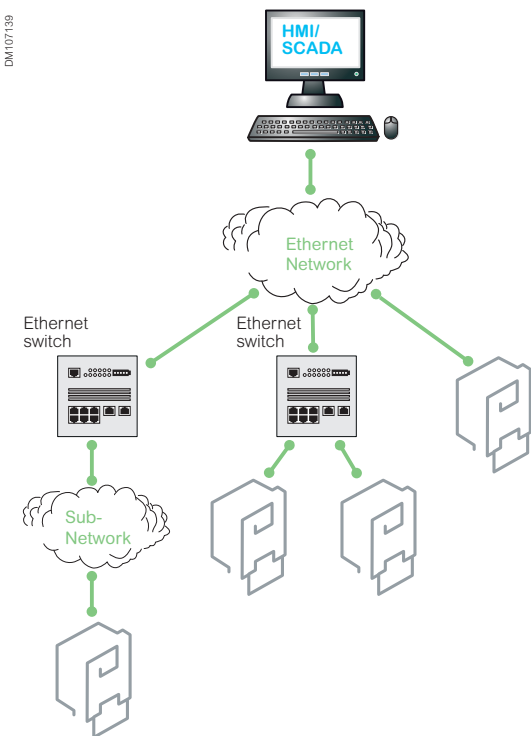

Connection to SCADA using Ethernet

This architecture allows you to connect a set of PowerLogic P5 protection relays directly to an Ethernet network.

Available protocols:

- IEC 61850 Edition 1 and Edition 2
- DNP3
- EtherNet/IP
- Modbus TCP/IP

Note: It is possible to mix IEC 61850 protocol with other communication or redundancy protocols from PowerLogic P5 on the same Ethernet network. This allows you to use GOOSE messages between relays together with another protocol for communication to SCADA. It is also possible to connect to two different control systems, using the same Ethernet communication port and IEC 61850 protocol for one network, and any available protocol for the second network.

Equipped with two Ethernet modules, PowerLogic P5x30 can handle 3 Ethernet protocols simultaneously with a single IP or 3 different IP addresses. Optionally, PowerLogic P5x30 offers a capability of dual redundancy providing PRP/HSR protocol for one system and a separate RSTP protocol for another system or engineering channel.

PowerLogic P5 protection relay handles the IEC 61850 station bus, in compliance with IEC 61850-6, 7-1, 7-2, 7-3, 7-4 and 8-1 Edition 1 or Edition 2 standards, according to the configuration.

Other available Ethernet protocols:

- sFTP for file transfer
- SNTP for time synchronization
- PTP for precise time synchronisation according to IEEE 1588v2 standard
- HTTPs for web server (setting changes)

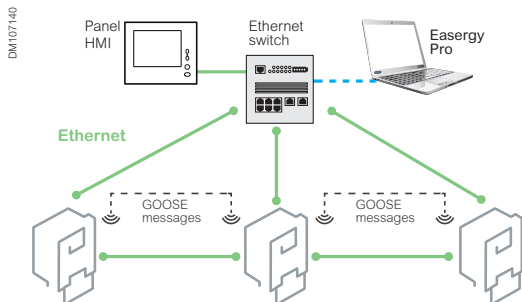

Switchboard internal network

This architecture allows fast GOOSE communication between PowerLogic protection relays in the same switchboard, this avoiding costly wiring. Typical uses are logic discrimination, load shedding, etc.

In addition, a panel HMI featuring a web browser can be used to monitor and control the entire switchboard.

A spare connection on the panel Ethernet switch can also be provided for connecting the eSetup Easergy Pro setting and configuration tool. On PowerLogic P5x30 models, two independent Ethernet communication modules are available. This allows implementation of the switchboard internal network and the communication to SCADA on two separate Ethernet networks.

DM107141

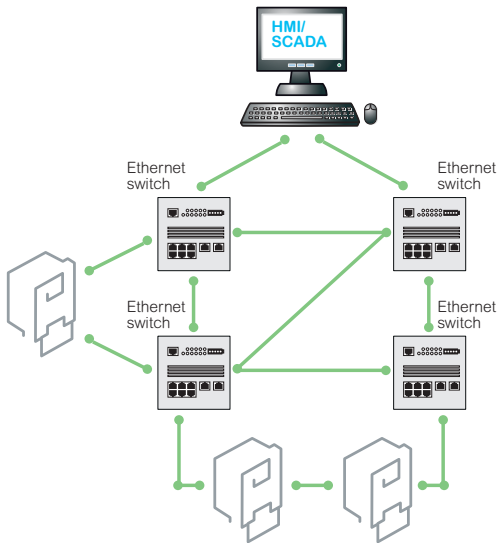

RSTP (Rapid Spanning Tree Protocol)

The principle of RSTP is to virtually remove all links that are not necessary at a given time, changing the meshed topology into a tree topology.

The main advantage of RSTP is that it is widespread and works on any network topology. On the other hand, RSTP takes milliseconds or seconds to reconfigure the network in case of network interruption.

With PowerLogic P5, the typical reconfiguration time for a loop of 10 relays is 0,050s.

DM107142

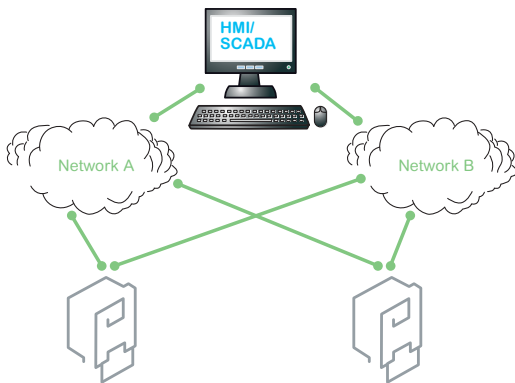

PRP (Parallel Redundancy Protocol)

The principle of PRP is to transmit frames in parallel on two independent network infrastructures: A and B.

The receiving device is in charge of removing the redundant frame, if it has already been received.

PRP protocol provides an instantaneous recovery time in case of failure, since no re-transmission of the message is needed.

DM107143

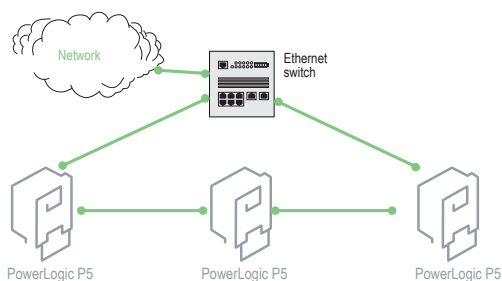

HSR (High-availability Seamless Redundancy)

HSR is similar to PRP but only works on a ring architecture.

Frames are transmitted on the ring in both directions and the receiving device eliminates redundant frames.

HSR protocol provides an instantaneous recovery time and is an alternative to PRP when network topology is restricted to a ring.

Both PRP and HSR protocols are listed in IEC 62439-3 as part of IEC 61850 standard. They both provide standardized, interoperable and high performance redundant Ethernet solutions.

PowerLogic P5 protection relays offer following solutions for time synchronization:
Communication protocol, Minute Pulse, IRIG-B, SNTP and PTP.

In modern protective schemes it is required to synchronize the internal real-time clock of the relay, so that events from different relays can be placed in chronological order.

This can be done using the communication interfaces connected to the substation control system or via dedicated time synchronization options provided by PowerLogic P5 relays: minute pulse, IRIG-B time code and SNTP or PTP IEEE 1588v2 over Ethernet networks.

Minute pulses

The clock can be synchronized by reading minute pulses from digital inputs, virtual inputs or virtual outputs. The sync source is selected with the SyncDI setting.

When a rising edge is detected from the selected input, the system clock is adjusted to the nearest minute.

IRIG-B

Inter-Range Instrumentation Group time code B (IRIG-B) is a standard format for transferring timing information. IRIG-B time synchronization standard is based on a frame of 100 data bits sent every second to the device.

This time synchronization standard is supported in PowerLogic P5 by the IRIG-B module connected to the optional extension module of the relay.

The module provides both a modulated and an unmodulated input and can automatically detect which input type is used. The time synchronization accuracy in PowerLogic P5 with this mode is less than 5 ms. For more information, see the IRIG-B module details so [page 89](#).

SNTP

Simple Network Time Protocol (SNTP) is a less complex implementation of Network Time Protocol (NTP), using the same protocol but without requiring the storage of state over extended periods of time. SNTP is used to synchronize the clocks of computer systems over packet switched, variable-latency data networks.

A jitter buffer is used to reduce the effects of variable latency introduced by queuing in packet switched networks, ensuring a continuous data stream over the network.

The PowerLogic P5 protection relay receives the synchronization from the SNTP/NTP server. The time synchronization accuracy in this mode is less than 5 ms.

PTP

Precision Time Protocol according to IEEE 1588-2008 (v2) standard. The PTP implementation in PowerLogic P5 protection relay is compliant to IEC61850-9-3 standard. This protocol enables precise synchronization of clocks in measurement and control systems implemented with technologies such as network communication, local computing, and distributed objects.

The protocol is applicable to systems communicating via Ethernet. Systemwide synchronization accuracy and precision in the sub-microsecond range are supported with minimal network and local clock computing resources. The time synchronization accuracy in PowerLogic P5 with this mode is less than 1 ms.

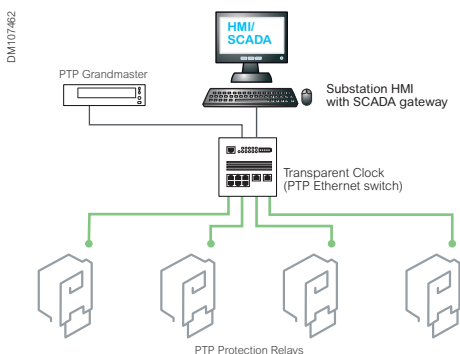
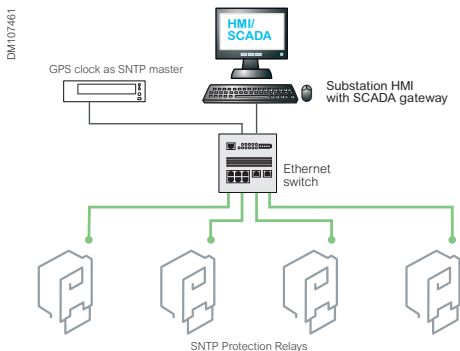
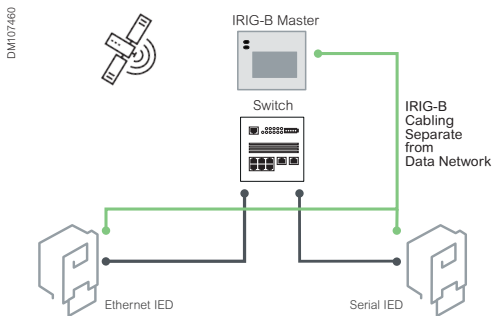

Communication

Data Exchanged

Data exchanged with SCADA

Ports	Ethernet			Serial or Ethernet		Serial	
	IEC 61850	Ethernet/IP	sFTP	DNP3	Modbus	IEC 60870-5-103	IEC 60870-5-101

Real time data

Measurement	•	•	-	•	•	•	•
Alarms and status	•	•	-	•	•	•	•
Controls	•	•	-	•	•	•	•
Time-stamped events	•	•	-	•	•	•	•

Historical data

Disturbance records	-	-	•	•	•	•	-
---------------------	---	---	---	---	---	---	---

Setting management

Setting group change	•	•	-	•	•	•	•
Settings	•	-	-	-	•	•	-

PowerLogic P5 protection relay is an easy to handle and flexible network component ready for end-to-end IEC 61850 engineering.

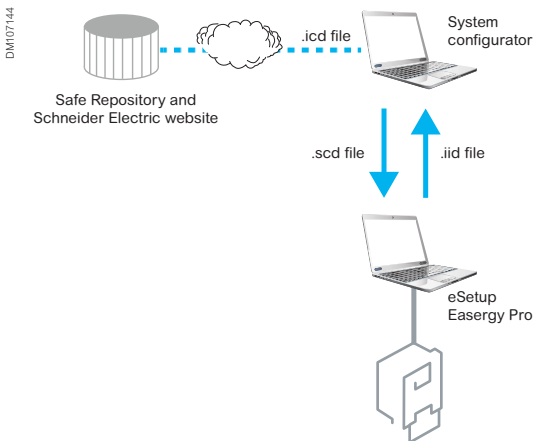

Data exchange according to IEC 61850

Overview

IEC 61850 is a series of standards for communication networks and systems in power grids which has become widely used in utility and industrial applications around the globe. The versatility and the interoperability throughout the entire lifecycle are main advantages of this standard. Having a strong foundation of multiple communication ports with various redundancy protocols and proven performance, PowerLogic P5 is ready for demanding IEC 61850 applications. PowerLogic P5 protection relays offer up to 8 simultaneous IEC 61850 client-server associations and up to 3 access points. This helps to realize the most advanced network topologies combining vertical (Edge/SCADA) and horizontal (GOOSE) communication modes and multiple services.

Compared to various other communication protocols the IEC 61850 standard brings significant improvement in terms of system engineering and deployment. With a top-down configuration approach, the users are able to design, configure, operate and maintain their IEC 61850 based systems in a more efficient and reliable way. PowerLogic P5 and its configuration tools are well prepared for standardized IEC 61850 system engineering and bring the Flexible Product Naming (fPN) feature for smoother, vendor independent integration of substation automation systems. Flexible Product Naming allows re-naming and re-mapping of the IEC 61850 device data model of an PowerLogic P5 to a user defined data model aligning with the users standard. With the help of this configuration feature the names of Logical Devices, the names of Logical Nodes instances and the Data Objects which they contain, as well as the names of Data Sets and Control Blocks can be aligned to a user defined naming concept.

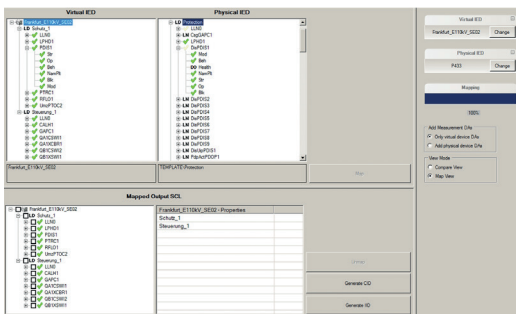
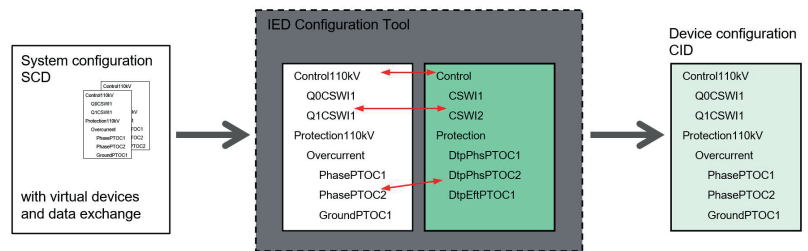

fPN Editor view demonstrating side-by-side data model mapping.

fPN Editor

The fPN Editor tool provides a clear separation between the user definition and the PowerLogic P5 device data model. Mapping of the two is made on a simple drag & drop basis. There are two ways of customizing PowerLogic P5 data models:

- The user defines vendor agnostic data models of fictive IEDs and creates a system configuration out of them. One after the other PowerLogic P5 devices are mapped against these fictive IEDs. This method brings full flexibility when engineering the system but results in multiple mappings for similar IEDs.
- The user defines typical IED data models and maps selected IED types to these typicals. The system configuration is created making use of the customized IED templates. This method brings reduced mapping effort but limits system engineering to pre-selected IEDs.

The Flexible Product Naming functionality of PowerLogic P5 enables smooth and vendor independent IEC 61850 configuration deployment. In connection EcoS-truxure Power Automation System Engineering tool (EPAS-E) or other vendor engineering tools PowerLogic P5 becomes a easy to handle and flexible network component ready for end-to-end engineering.

Cybersecurity features implemented in PowerLogic P5 help to mitigate cyber threats.

PowerLogic P5 can be set, either with:

- Cybersecurity basic level, or
- Cybersecurity advanced level, 3rd party certified according to IEC 62443 4-2 at Security Level 1

Cybersecurity

Cybersecurity in the scope of energy management is a set of rules, methods, and technical features intended to improve the quality of service and minimize risk of interruption of deliveries, resulting from accidental or intentional actions.

The PowerLogic P5 protection relay is designed with special attention to cybersecurity aspects, with compliance to Schneider Electric's [Cybersecurity Policy](#) and following Secure Development Lifecycle process.

All these efforts have been proved in obtaining certificates of Level 1 and Level 2 of Achilles Communications Certification Standard.

Depending on customer needs, the PowerLogic P5 protection relay can be set with Cybersecurity Basic Level or Advanced Level. Each PowerLogic P5 is delivered with Cybersecurity Basic Level as a default setting. It can be easily upgraded to Cybersecurity Advanced Level with a change of settings.

Cybersecurity Basic Level

The features available for Basic Level are also found in the Advanced Level.

- Secured communication between PowerLogic P5 protection relays and associated tools.
- Protection of the hardware and logical communication ports.
- Firmware signature.
- Password based user authentication.
- Role Based Access Control (RBAC) authorization management.
- Secured log storage.
- Client IP address filter
- Compliance to NERC CIP and BDEW standard requirements.

More info on the Schneider Electric
Cybersecurity Support portal:

www.se.com/ww/en/work/support/cybersecurity/overview.jsp





Cybersecurity Advanced Level with EcoStruxure Cybersecurity Admin Expert - proven in 3rd party certification according to the standard IEC 62443 4-2 Security Level 1

With the cybersecurity advanced package, PowerLogic P5 protection relays take benefit of EcoStruxure Cybersecurity Admin Expert (CAE), a comprehensive and intuitive, software-based, cybersecurity configuration and policy tool for your operational technology environment.

EcoStruxure Cybersecurity Admin Expert (CAE) facilitates operations and maintenance, being a single interface to manage and perform a mass update of your security configuration to the entire system.

EcoStruxure Cybersecurity Admin Expert (CAE) is free-of-charge and helps to:

- Define the security policy, including for example: password complexity or password strategy.
- Define rules for security logs, choose between NERC CIP, BDEW, P1686 2014 or a combination.
- Define the RBAC (Role Base Access Control) parameters of your environment.
- Define system or device users and assign one or several roles per user customized based on organization.
- Retrieve security logs including several Schneider Electric devices.

In summary, with cybersecurity advanced package, the PowerLogic P5 protection relay becomes part of a cybersecurity management system consisting of servers for security logs, authentication and authorization, using standard network protocols.

EcoStruxure Cybersecurity Admin Expert (CAE) facilitates the management of cybersecurity in your electrical network's operational technology (OT) from policy definition, thru configuration, commissioning, operation and maintenance stages.

Two usecases are available for authentication and authorization features:

Advanced - Local Authentication and Authorization

In this use case, local authentication and authorization don't rely on any external servers. Security configuration is stored locally in each PowerLogic P5. User authentication and authorization using associated roles are performed locally (RBAC). CAE is used to update the global security configuration of all the PowerLogic P5 devices located inside the substation.

Advanced - Centralized Authentication and Authorization

In this use case, centralized authentication and authorization relies on one or two Radius or LDAP servers with the IEC 62351-8 extension. This allows the use of a Unified Account management system shared across heterogenous solutions. The same credentials are used at the front panel of each device, tools and also third party devices. The Radius or LDAP server is in charge of authenticating users and providing the associated role. Then PowerLogic P5 protection relays allow access based on this role and the internal security configuration (RBAC).

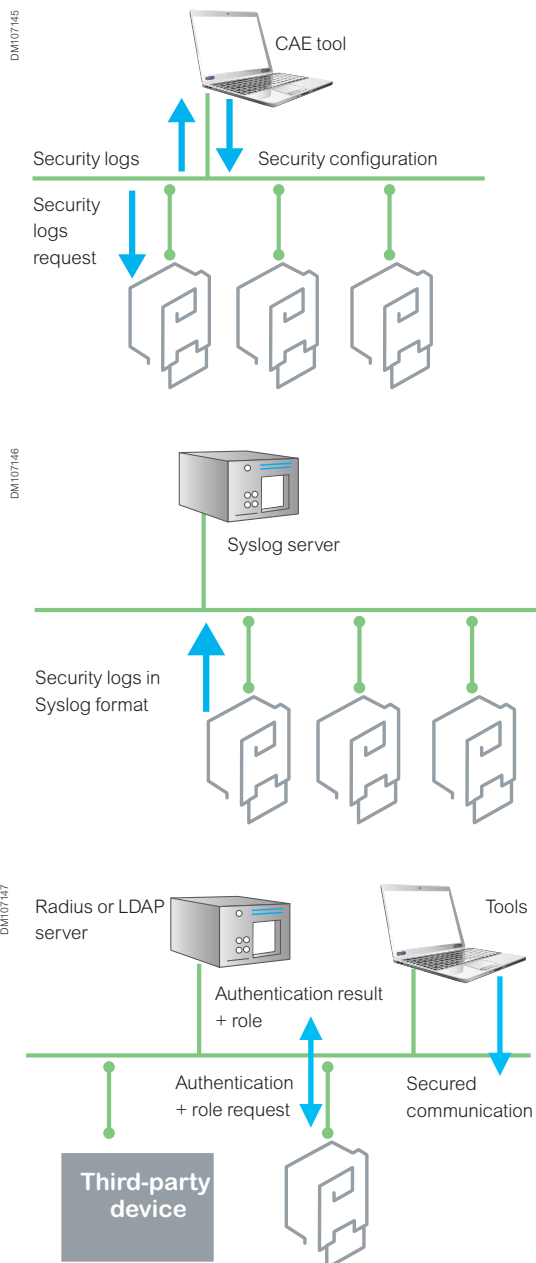

PowerLogic P5 Product Description

PowerLogic P5

Product Description

Functional Description	52
PowerLogic P5U20 - Universal application	52
PowerLogic P5U20 - Universal application with LPCT/LPVT	53
PowerLogic P5V20 - Voltage application	54
PowerLogic P5F30 - Feeder application	55
PowerLogic P5M30 - Motor application	56
PowerLogic P5T30 - Transformer Differential application	57
<hr/>	
Base Unit Description	58
Hardware specification	58
Rear panel description - CT/VT variant	62
Rear panel description - LPCT/LPVT variant	63
Front panel description	64
PowerLogic P5x20 - Front panel description	65
PowerLogic P5x30 - Front panel description	66
PowerLogic P5x20 - dimensions and weight	67
PowerLogic P5x30 - dimensions and weight	68
<hr/>	
Connection Diagrams	69
Current Transformers (and LPCT)	69
Voltage Transformers (and LPVT)	70
Power Supply, Inputs and Outputs	71
<hr/>	
Technical Characteristics	74
Electrical characteristics	74
Environmental characteristics	76
Other characteristics	77

Functional Description

PowerLogic P5U20 - Universal application with CT

PowerLogic P5U20 is used for feeder (incomer and outgoing), motor, or distribution transformer protection.

It offers a complete set of current-based protection functions and measurement, control facilities and recording/monitoring functions for efficient operation of the power system.

DM107160

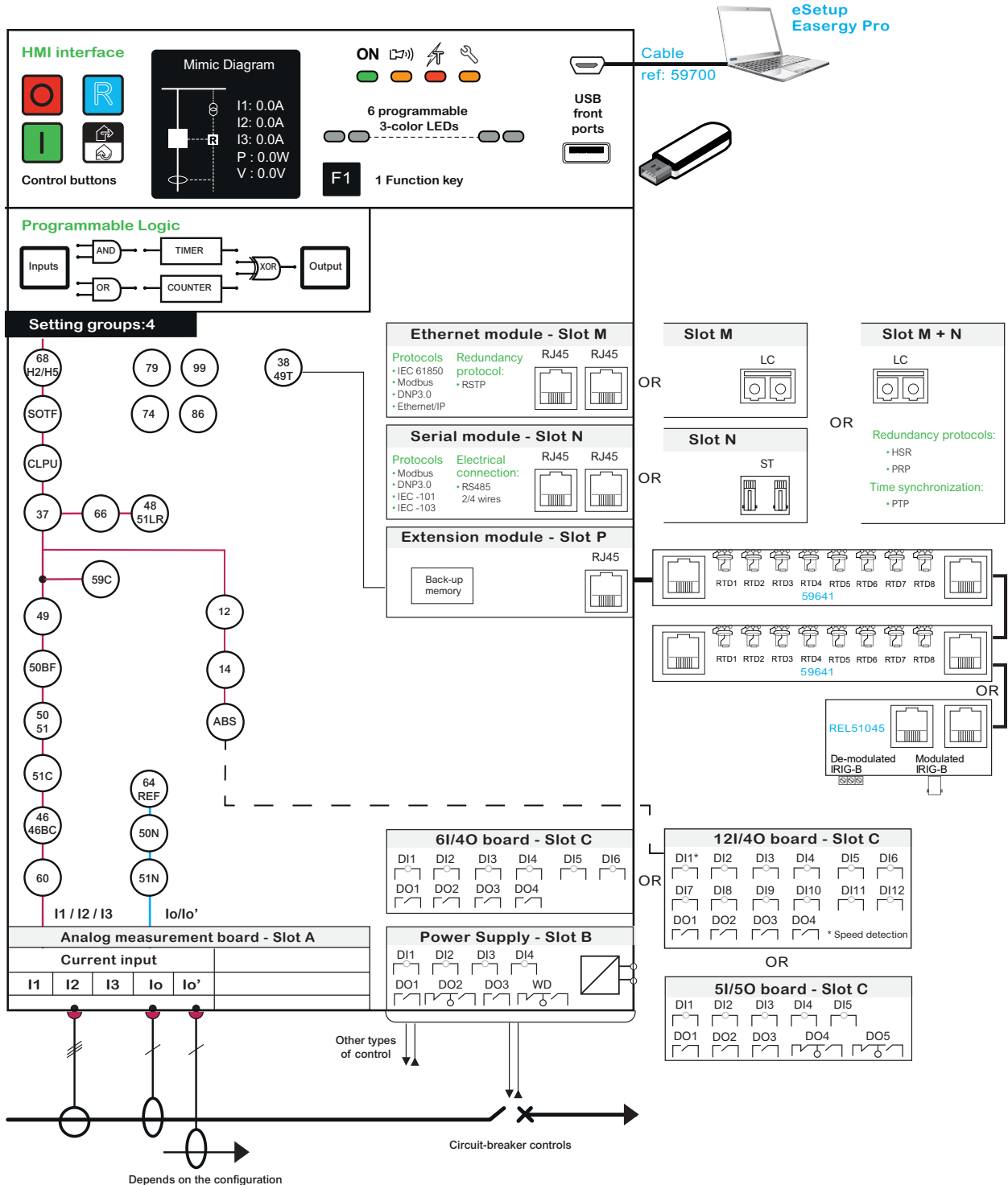

Functional Description

PowerLogic P5U20 - Universal application with LPCT/LPVT

PowerLogic P5U20 with Low Power CTs/VTs can be used for feeder (incoming and outgoing), motor, or distribution transformer protection. It offers essential current and voltage based protection functions, measurements, control facilities and recording/monitoring features for efficient operation of the power system. It is designed for use with low-power sensors and is applicable in distribution networks of industrial installations and utility substations for all levels of voltages.

DM107150b

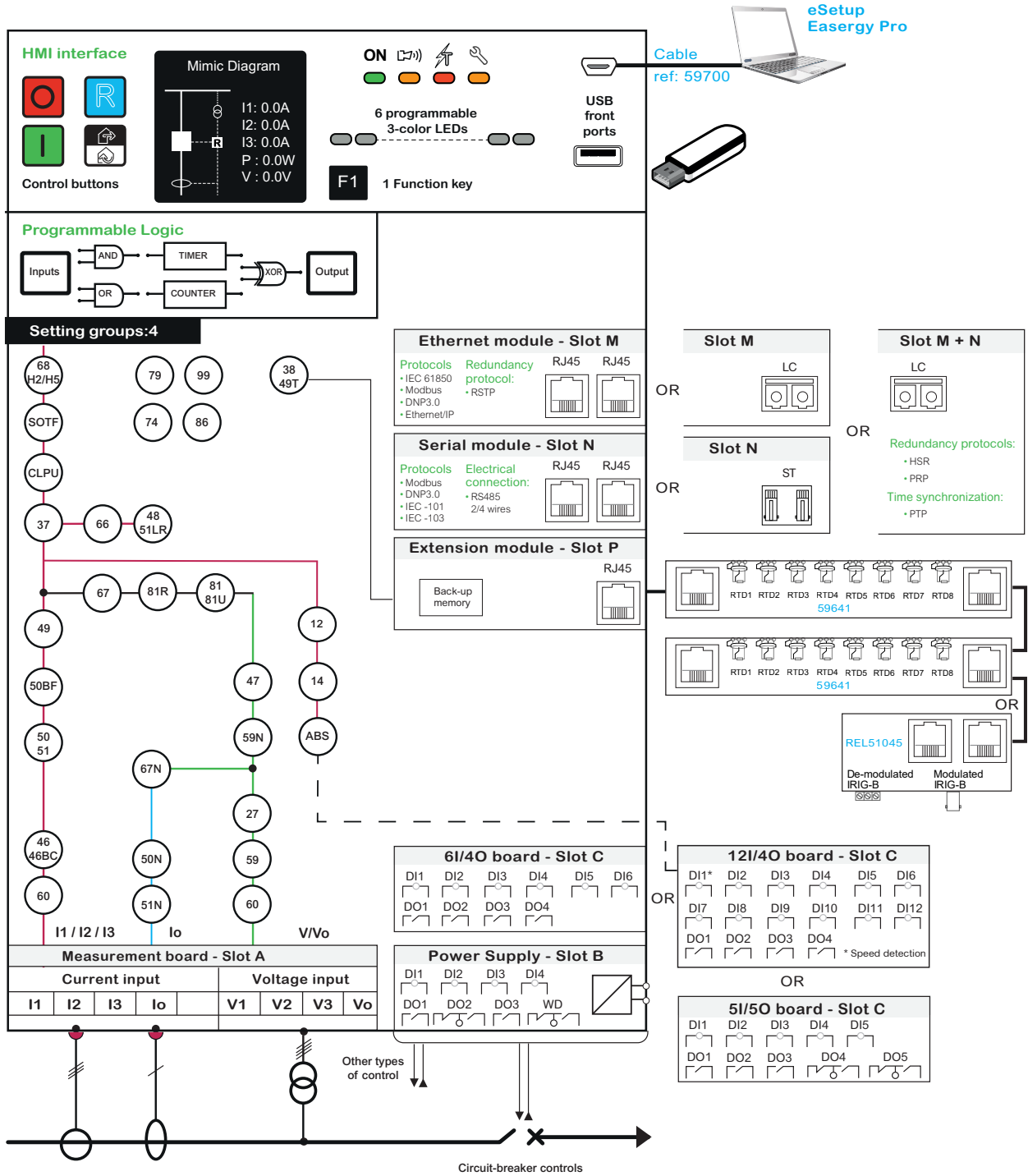

Functional Description

PowerLogic P5V20 - Voltage application with VT

PowerLogic P5V20 protection relay offers a complete set of voltage and frequency protection functions, as well as measurements and recording/monitoring functions for efficient operation of the power system.

In addition it can be used for the control of switchgear.

DM107151

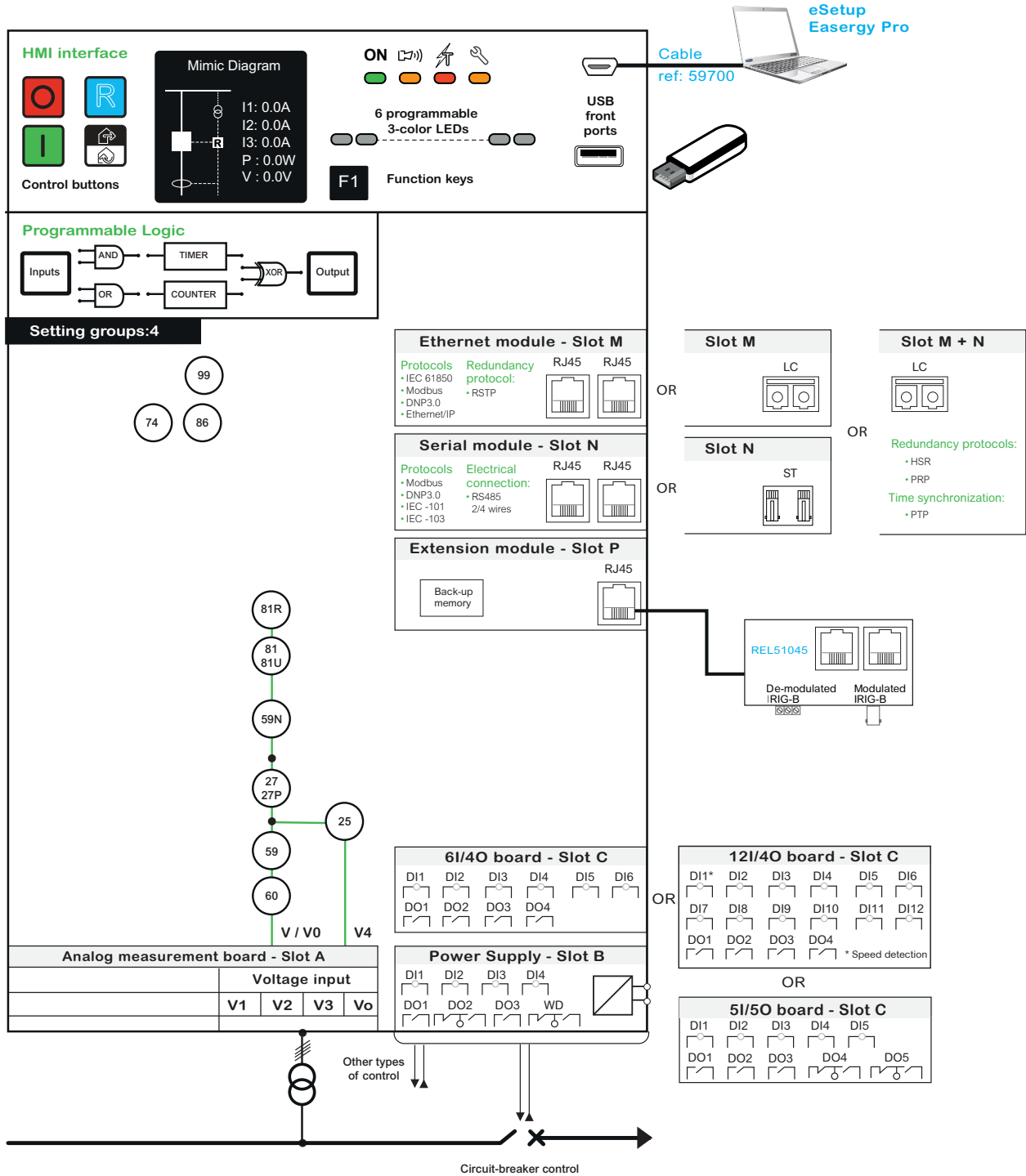

Functional Description

PowerLogic P5F30 - Feeder application with CT/VT or LPCT/LPV

PowerLogic P5F30 protection relay is designed for the operation of electrical distribution networks of industrial installations and utility substations for all levels of voltages. It offers a complete set of current and voltage based protection functions, measurements, control facilities and recording/monitoring functions for efficient operation of the power system. It is suitable for application on solidly grounded, impedance grounded, Petersen coil grounded and isolated systems.

DM107448

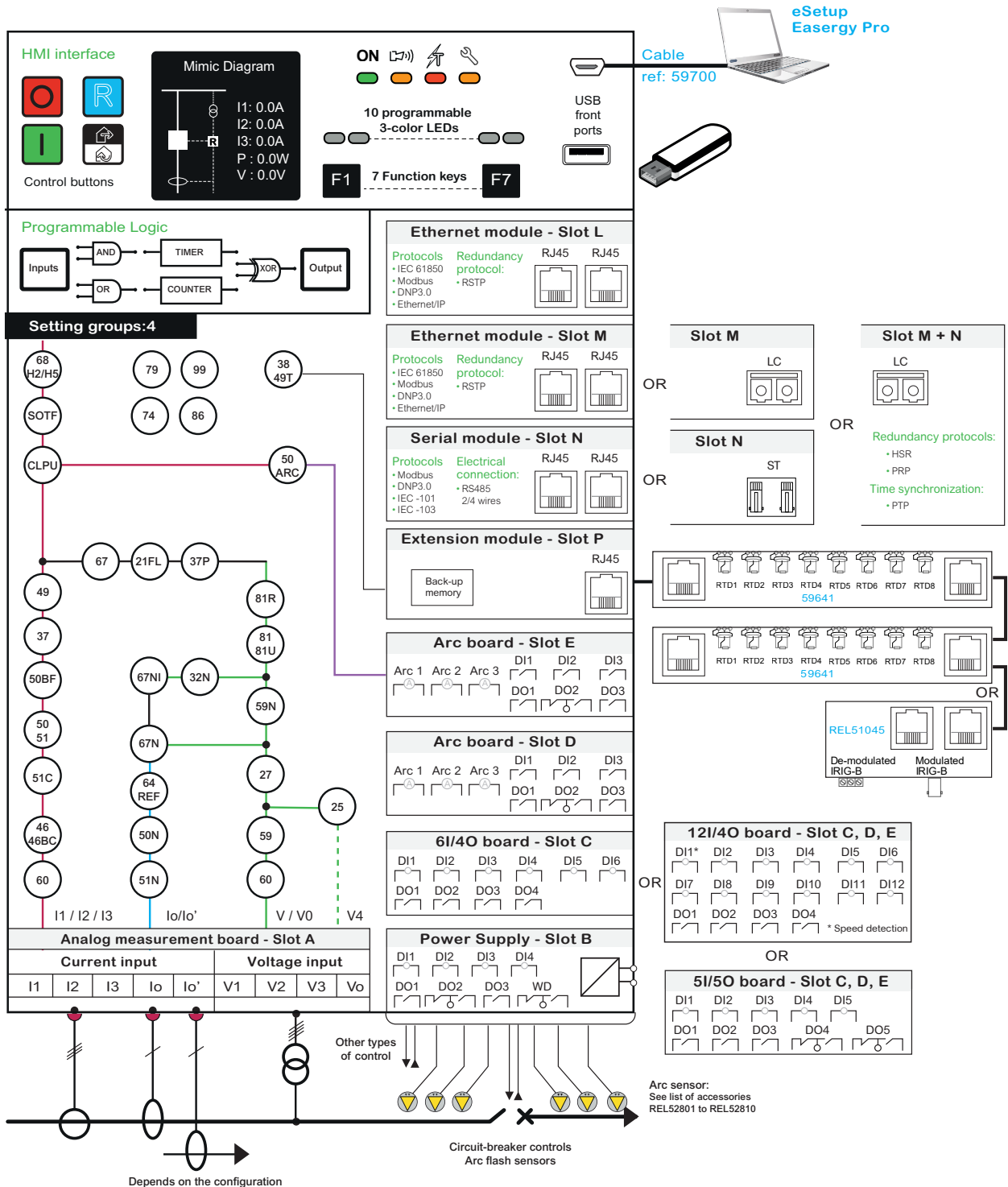

Functional Description

PowerLogic P5M30 - Motor application
with CT/VT or LPCT/LPVT

PowerLogic P5M30 protection relays are a compact solution developed and designed for medium and large sized rotating machines, performing an essential role in many industrial processes and generation. It offers more than a conventional protection relay, with numerous additional functions suitable and crucial for a wide range of applications, which involve protection, monitoring, diagnosis, fault analysis tools, and maintenance aids.

DM107449

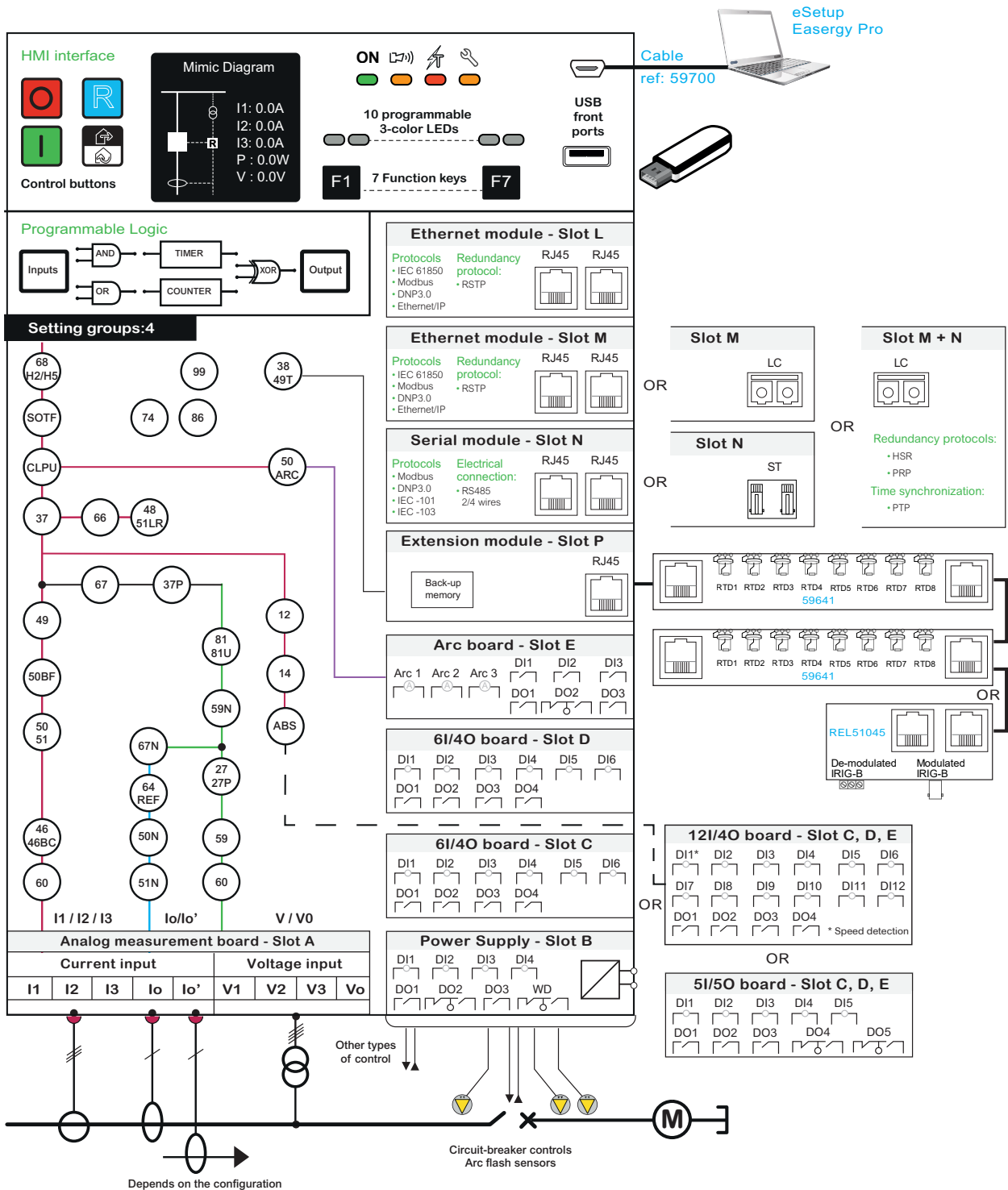

Functional Description

PowerLogic P5T30 - Transformer Differential application with CT/VT

PowerLogic P5T30 protection relays are a compact solution designed for medium and large sized power transformers, unit and step-up transformers in industrial and utility networks. It offers more than a conventional protection relay, with high density of inputs/outputs and strong communication profile as well as with numerous additional functions suitable and crucial for a wide range of applications which involve protection, automation and control, monitoring and diagnosis.

DM107449

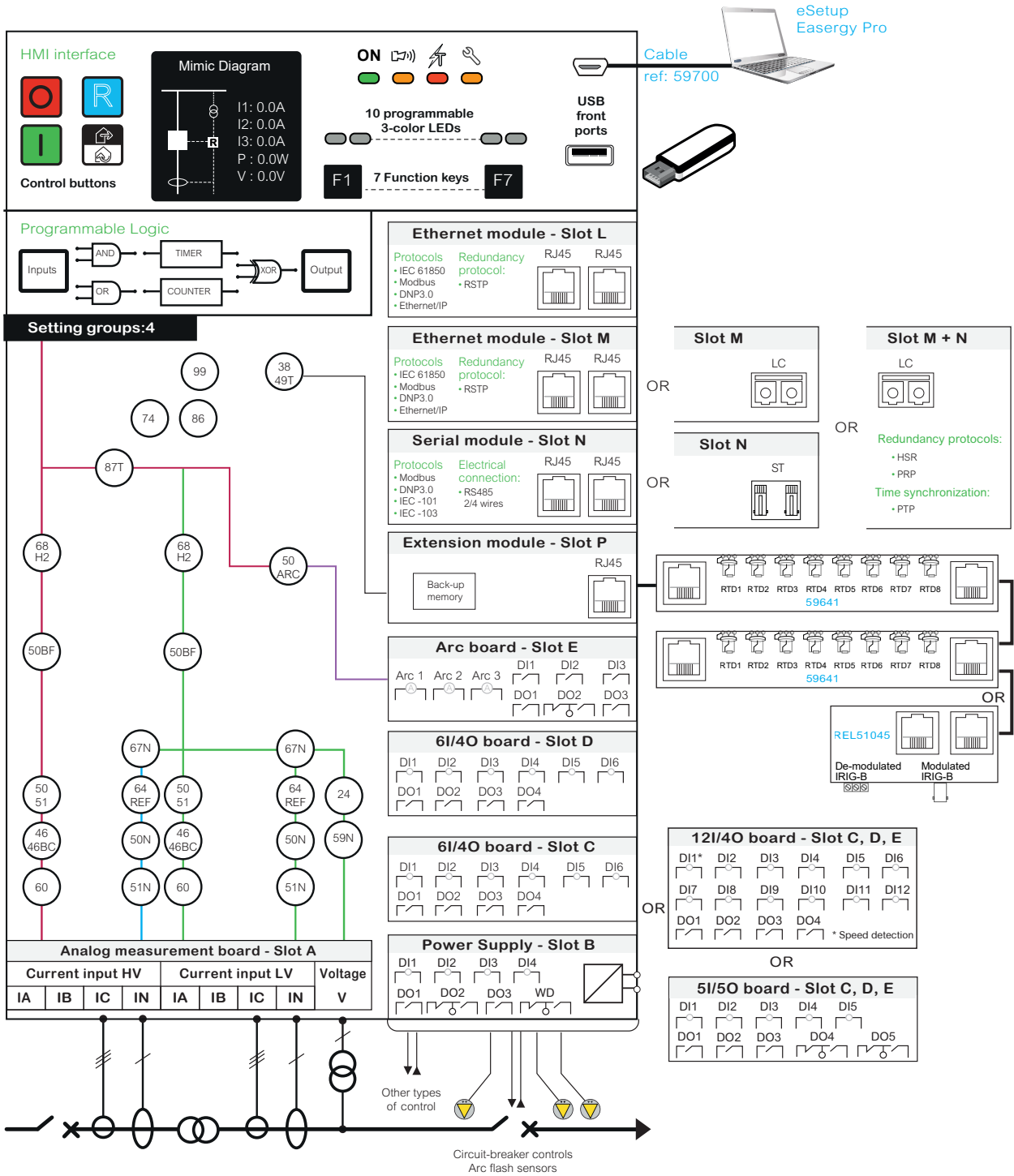

Base Unit Description

Hardware Description

Withdrawable design (draw-out)

PowerLogic P5 protection relays can be drawn-out, offering faster and easier maintenance with less risk:

1. Removable part (including the I/O board, CPU board and power supply) can be easily replaced if required.
2. Thanks to the backup memory included in the extension module (optional), configuration and log records are automatically reloaded, allowing quick relay restart without additional configuration. No recommissioning is necessary.
3. The CT and VT inputs are isolated when the device is withdrawn.



Base Unit Description

Hardware Specification

Optional modules



Options in slots A, B, C, D, E must be selected when ordering the device (measuring inputs, power supply and input/output optional boards).

Communication modules in slots L, M, N, P can be ordered separately and added on site when more communication capabilities are required. The relay will automatically integrate added modules.

Additionally, external modules are available for RTD inputs and for IRIG-B time synchronization.



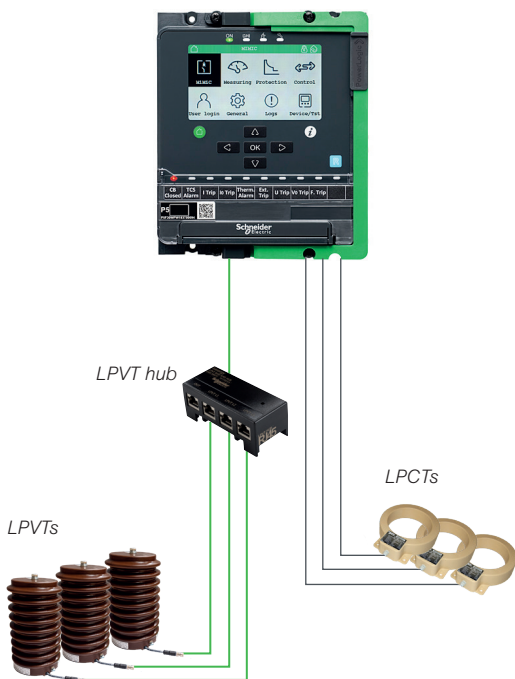

LPCT and LPVT connection to
PowerLogic P5U20, P5F30 and P5M30 protection relays

Compatibility with low power sensors LPCT/LPVT...

PowerLogic P5 relays can be ordered with either a conventional CT/VT measuring module or with a low-power CT/VT measuring module, compatible with low-power sensors compliant to IEC 61869-10 and IEC 61869-11 standards.

PowerLogic P5 protection relays can work with both resistive divider and capacitive divider LPVTs.

Low Power Current Transformer (LPCT) is a magnetic sensor with integrated shunt providing a voltage output (mV) which represents the primary current (A). LPCTs provide a low voltage output signal compatible with PowerLogic P5 protection relays.

Low Power Voltage Transformer (LPVT) is a voltage sensor based on resistor dividers for digital protection and measuring devices. LPVTs provide a low voltage output signal compatible with PowerLogic P5 protection relays.

The LPCT/LPVT compatibility of PowerLogic P5 allows users to move from conventional instrument transformers to better low power sensors technology which brings a variety of benefits at every stage of the project and throughout the whole life cycle of your installation.

...for more reliability...

Low power sensors are free of ferroresonance and represent high accuracy up to short circuit levels.

They can be used in protection and measurement purposes with very wide operating range. This technology ensures easier maintenance thanks to very low voltage values present on the secondary side.

...simplicity...

Solutions bring significant simplification during project execution stage.

Simpler engineering (no CT sizing), procurement, stocking (very less variants) and installation ensures high effectiveness and improves the project delivery time.

...and flexibility

Choosing low power sensors it's possible to optimize medium voltage switchgear design thanks to sharing of LPVT signal across multiple PowerLogic P5 protection relays.

Secondary testing can be done directly or with dedicated test sockets and plugs, respecting the procedures known from conventional CT/VT schemes.



LPCT TLP130 - 0,72 kV insulation



LPVT GIS type C - 24 kV insulation



LPVT transducer allowing to transmit LPVT signal across multiple PowerLogic P5 devices



LPCT test socket and plug Essalec® from TE Connectivity



LPVT test socket and plug Essalec® from TE Connectivity



LPCT/LPVT Test Box

Optimization of switchgear design with LPVT sharing application

Similarly to conventional schemes, low power voltage transformer (LPVT) signal can be shared across up to 10 PowerLogic P5 protection relays per one LPVT transducer. The LPVT signal can be shared throughout medium voltage cubicles ensuring significant economies in the useage of primary voltage sensing equipment. All connections are made with screened RJ45 cables and resilient to potential electromagnetic disturbances met in medium voltage compartments.

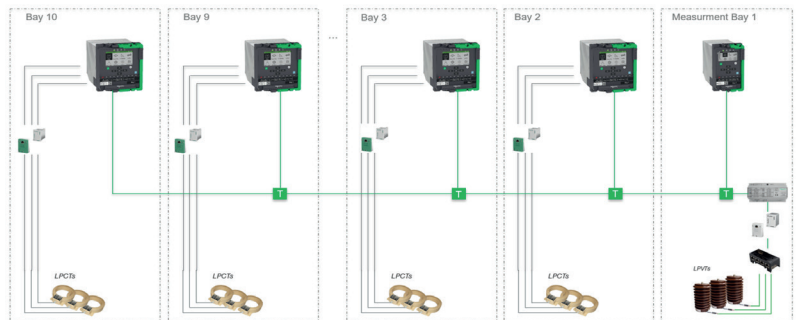

Comfortable solution for LPCT/LPVT testing

For secondary testing purposes, there is a LPCT/LPVT test box which allows to interconnect Omicron testing kit with PowerLogic P5 protection relay and test LPCT/LPVT inputs properly in the entire meausurement range at the requested accuracy. This option limits the doubts related to testing of the LPCT/LPVT solution and brings more comfort to the testing practices.

LPCT and LPVT test sockets and plugs can be used to make an accessible provision for testing in the front plate of medium voltage switchgear. The test sockets and plugs are housed in the same case as for the conventional CT/VT solution and allows the Users to replicate the same testing procedures. The test sockets and plugs simplify test operation. The testing can be done without opening the medium voltage cubicle door and avoids any manipulations with wiring. This improves the commissioning and periodic testing.

Base Unit Description

Rear panel description - CT/VT variant

Rear communication modules:

- ETH** Dual port copper (RJ45) or optical fibre (multimode glass fiber) Ethernet module
- SRL** RS485 or optical fibre serial communication module
- EXT !** Extension port for connection with external modules

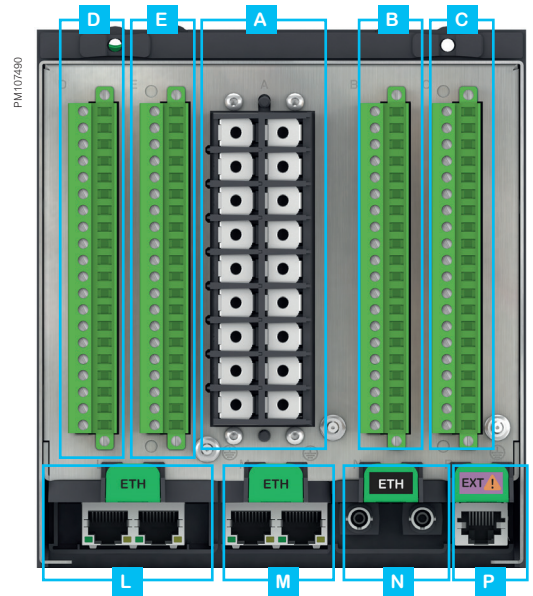
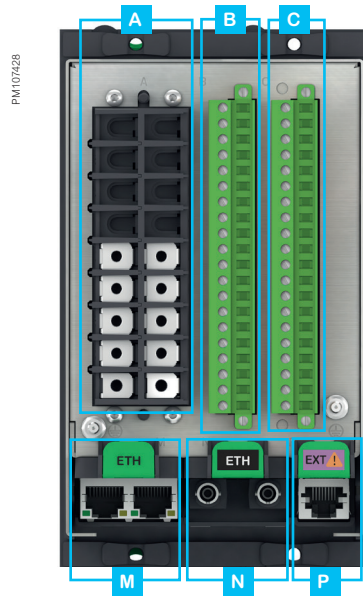

PowerLogic P5x20 - CT/VT variant

PowerLogic P5x30 - CT/VT variant

Slot A Measuring inputs

3 phase CT + 2 residual CT or
3 phase CT + CSH core balance CT
4 VT

Slot B Power supply and digital I/O

24-250 V_{DC} / 100-230 V_{AC}
+ 4 DI + 3 DO + watchdog (WD)

Slot C ⁽¹⁾ Additional digital inputs and outputs 1

6 DI + 4 DO or 12 DI + 4 DO ⁽²⁾
or 5 DI + 5 DO ⁽³⁾

Slot D ⁽¹⁾ Additional digital inputs and outputs 2

Slot E ⁽¹⁾ Additional digital inputs and outputs 3

Slot M ⁽¹⁾ Communication interface 1
Ethernet port

Ethernet TP module with RSTP or Dual IP or
Ethernet FO module with RSTP or Dual IP

Slots M&N ⁽¹⁾ Communication interface 1
Ethernet port with PRP/HSR

Ethernet FO module
with HSR/PRP and PTP

Slot N ⁽¹⁾ Communication interface 2
Serial port

RS485 serial line module or
Fiber optic serial line module

Slot L ⁽¹⁾ Communication interface 3
Ethernet port

Second Ethernet TP module with RSTP

Slot P ⁽¹⁾ Extension port

Extension module with backup memory

Extension module with backup memory

(1) Optional board

(2) The 12 DI + 4 DO board includes one motor speed detection input

(3) The 5 DI + 5 DO board includes two high break / high speed contacts

NOTE: For P5x30 the slot occupation rules apply. Follow the PowerLogic P5 Product Selector at se.com or consult the PowerLogic P5 User Guide.

Base Unit Description

Rear panel description - LPCT/LPVT variant

Rear communication modules:

ETH Dual port copper (RJ45) or optical fibre (multimode glass fiber) Ethernet module

SRL RS485 or optical fibre serial communication module

EXT  Extension port for connection with external modules

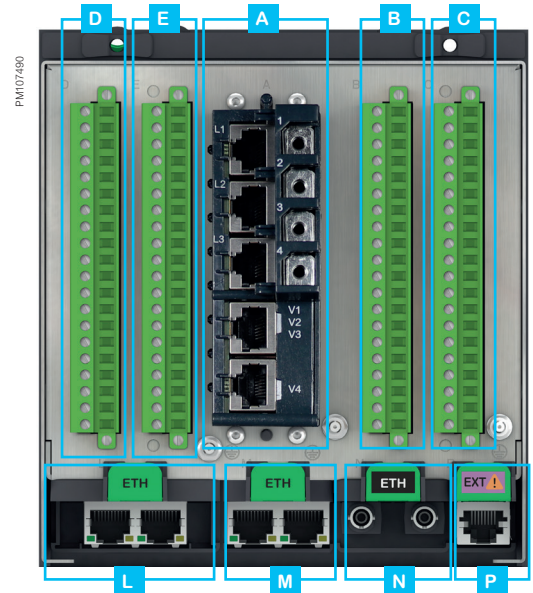
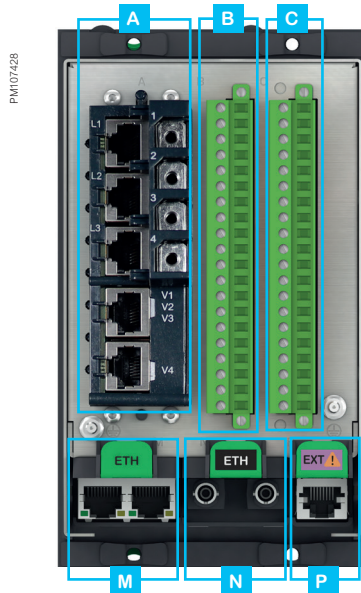

PowerLogic P5x20 - LPCT/LPVT variant

PowerLogic P5x30 - LPCT/LPVT variant

Slot	Module	PowerLogic P5x20 - LPCT/LPVT variant	PowerLogic P5x30 - LPCT/LPVT variant
Slot A	Measuring inputs	3 phase LPCT + CSH core balance CT + 4 LPVT	3 phase LPCT + CSH core balance CT + 4 LPVT
Slot B	Power supply and digital I/O	24-250 V _{DC} / 100-230 V _{AC} + 4 DI + 3 DO + watchdog (WD)	24 - 48 VDC or 48-250 V _{DC} / 100-230 V _{AC} + 4 DI + 3 DO + watchdog (WD)
Slot C ⁽¹⁾	Additional digital inputs and outputs 1	6 DI + 4 DO or 12 DI + 4 DO ⁽²⁾ or 5 DI + 5 DO ⁽³⁾	6 DI + 4 DO or 12 DI + 4 DO ⁽²⁾ or 5 DI + 5 DO ⁽³⁾
Slot D ⁽¹⁾	Additional digital inputs and outputs 2		6 DI + 4 DO or 12 DI + 4 DO ⁽²⁾ or 5 DI + 5 DO ⁽³⁾ or 3 Arc + 3 DI + 3 DO
Slot E ⁽¹⁾	Additional digital inputs and outputs 3		6 DI + 4 DO or 12 DI + 4 DO ⁽²⁾ or 5 DI + 5 DO ⁽³⁾ or 3 Arc + 3 DI + 3 DO
Slot M ⁽¹⁾	Communication interface 1 <i>Ethernet port</i>	Ethernet TP module with RSTP or Dual IP or Ethernet FO module with RSTP or Dual IP	Ethernet TP module with RSTP or Dual IP or Ethernet FO module with RSTP or Dual IP
Slots M&N ⁽¹⁾	Communication interface 1 <i>Ethernet port with PRP/HSR</i>	Ethernet FO module with HSR/PRP and PTP	Ethernet FO module with HSR/PRP and PTP
Slot N ⁽¹⁾	Communication interface 2 <i>Serial port</i>	RS485 serial line module or Fiber optic serial line module	RS485 serial line module or Fiber optic serial line module
Slot L ⁽¹⁾	Communication interface 3 <i>Ethernet port</i>		Second Ethernet TP module with RSTP
Slot P ⁽¹⁾	Extension port	Extension module with backup memory	Extension module with backup memory

(1) Optional board

(2) The 12 DI + 4 DO board includes one motor speed detection input

(3) The 5 DI + 5 DO board includes two high break / high speed contacts

NOTE: For P5x30 the slot occupation rules apply. Follow the PowerLogic P5 Product Selector at se.com or consult the PowerLogic P5 User Guide.

Base Unit Description

Front panel description



Home page with easy navigation

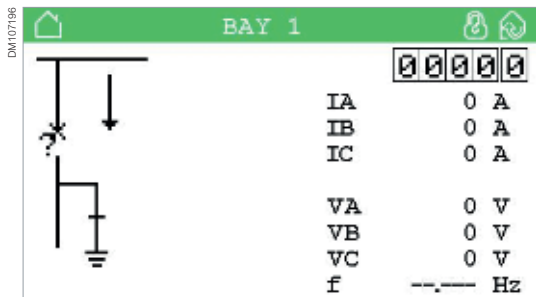

Single-line diagram for easy operation. Up to 5 switchable mimic screens for better flexibility.

Comprehensive data for fast and easy operation

All data required for a local equipment operation may be displayed on demand:

- Display the single-line diagrams and freely assignable analog values.
- Display of all measurements.
- Display of operation and alarm messages.
- Display and setting of all protection functions.
- Display and setting of all other functions and scaling parameters.
- Entry of password to protect parameter and protection settings.

Ergonomic data presentation













- 480 x 272 color LCD screen (PowerLogic P5x30 models) or 192 x 96 LCD screen (PowerLogic P5x20 models) can display any character or symbol
- Dedicated keys for operation:
 - Control buttons (O/I) to operate the circuit breaker and other controllable objects
 - Reset button (R) to clear the alarms and reset the lockout/latching function.
 - Local / Remote button
- Programmable function keys:
 - 1 on PowerLogic P5x20 models
 - 7 on PowerLogic P5x30 models
- Dedicated LEDs for indication of:
 - Power on
 - Relay maintenance
 - Trip
 - Alarm
- Tri-color programmable LEDs:
 - 6 on PowerLogic P5x20 models
 - 10 on PowerLogic P5x30 models

Working languages





All texts and messages displayed on the PowerLogic P5 protection relay are available in two languages: English plus a local language. PowerLogic P5 can be ordered with French, Chinese, Portuguese, Italian, Spanish, Polish, Russian, Traditional Chinese, and English ANSI.



Base Unit Description

PowerLogic P5x20 - Front panel description

KEYS	
	HOME key: return to previous menu. Three second press returns to main menu
	INFO push-button for viewing additional information, entering the password view, and adjusting the LCD contrast
	Reset control key
Navigation keys	 ENTER key: activate or confirm a function
	 UP key: move up in the menu or increase a numerical value
	 DOWN key: move down in the menu or decrease a numerical value
	 LEFT key: move backwards in a parallel menu or select a digit in a numerical value
	 RIGHT key: move forwards in a parallel menu or select a digit in a numerical value
	Switchgear control key (OPEN)
	Switchgear control key (CLOSE)
	Local/remote control key
	Customizable function key



LEDS	
	On (Green)
	Alarm (Yellow)
	Trip (Red)
	Maintenance (Yellow)
	6 customizable tri-color LEDs

PORTS	
	USB mini B (Computer)
	USB A (USB key)

ACCESS COVER (OPEN)

LABELS	
	Customizable LED labels
	Customizable Bay label

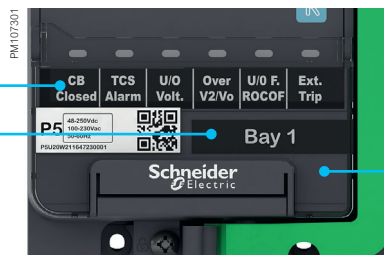

ACCESS COVER (CLOSED)

Base Unit Description

PowerLogic P5x30 - Front panel description

KEYS	
	HOME key: return to previous menu. Three second press returns to main menu
	INFO push-button for viewing additional information, entering the password view, and adjusting the LCD contrast
	Reset control key
	ENTER key: activate or confirm a function
	UP key: move up in the menu or increase a numerical value
	DOWN key: move down in the menu or decrease a numerical value
	LEFT key: move backwards in a parallel menu or select a digit in a numerical value
	RIGHT key: move forwards in a parallel menu or select a digit in a numerical value
	Switchgear control key (OPEN)
	Switchgear control key (CLOSE)
	Local/remote control key
	7 customizable function keys



LEDS	
	On (Green)
	Alarm (Yellow)
	Trip (Red)
	Maintenance (Yellow)
	10 customizable tri-color LEDs

PORTS	
	USB mini B (Computer)
	USB A (USB key)

ACCESS COVER (OPEN)

LABELS	
	Customizable LED labels
	Customizable Bay label

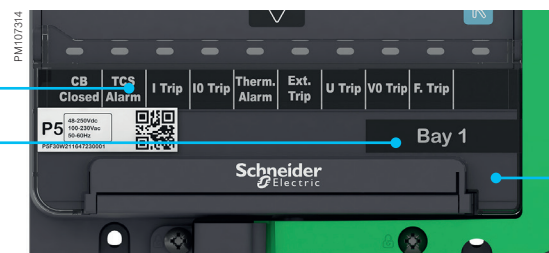

ACCESS COVER (CLOSED)

Base Unit Description

PowerLogic P5x20 - dimensions and weight

Dimensions and weight

Dimensions	mm	in
Height	180	7.08
Width	102	4.01
Depth	224	8.82
Weight	kg	lb
Weight	2.5 to 3.5	5.5 to 7.7

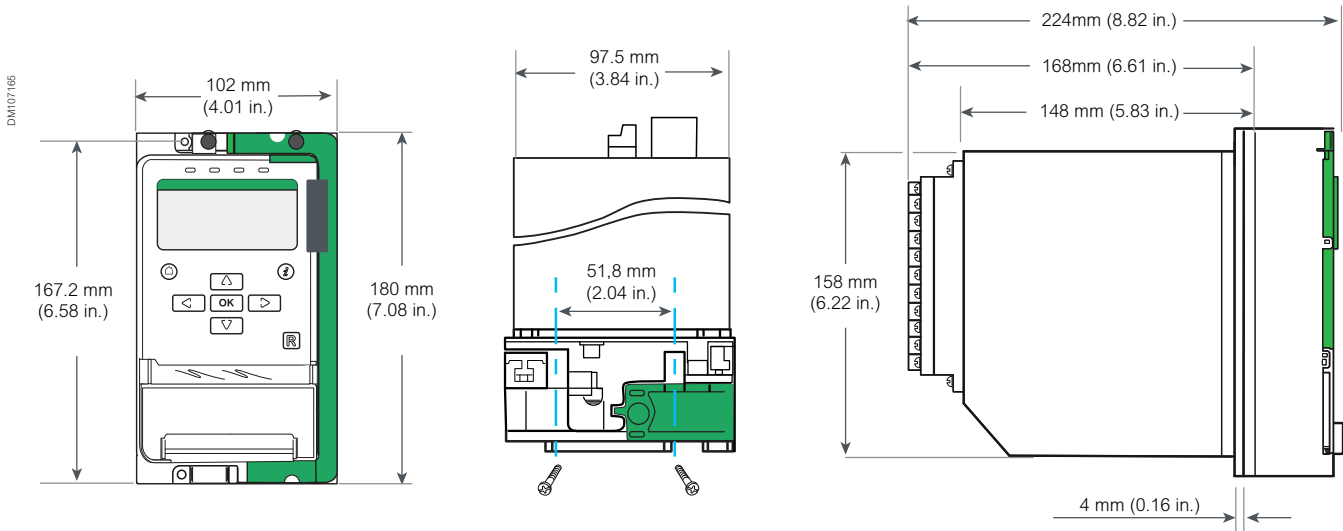

Flush mounting with accessory

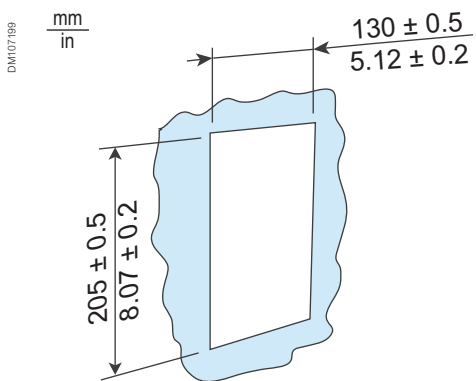

Cut-out dimensions	mm	in
Height	205 ± 0.5	8.07 ± 0.2
Width	130 ± 0.5	5.12 ± 0.2

Flush mounting without accessory

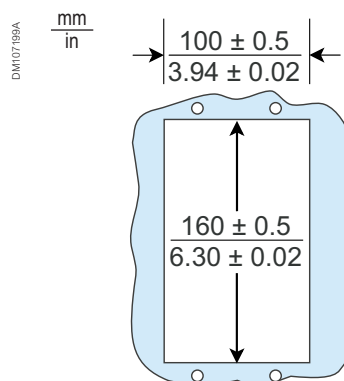

Cut-out dimensions	mm	in
Height	160 ± 0.5	6.30 ± 0.02
Width	100 ± 0.5	3.94 ± 0.02

More info on installation accessories [page 98](#)

NOTE 1: PowerLogic P5 relays can be mounted in rack. Please consult User Guide for more details.

NOTE 2: Please see the appropriate Safety Guide or User Guide for correct installation information.

Base Unit Description

PowerLogic P5x30 - dimensions and weight

Dimension and weight

Dimensions	mm	in
Height	180	7.08
Width	152.4	6
Depth	224	8.82
Weight	kg	lb
Weight	2.5 to 3.5	5.5 to 7.7

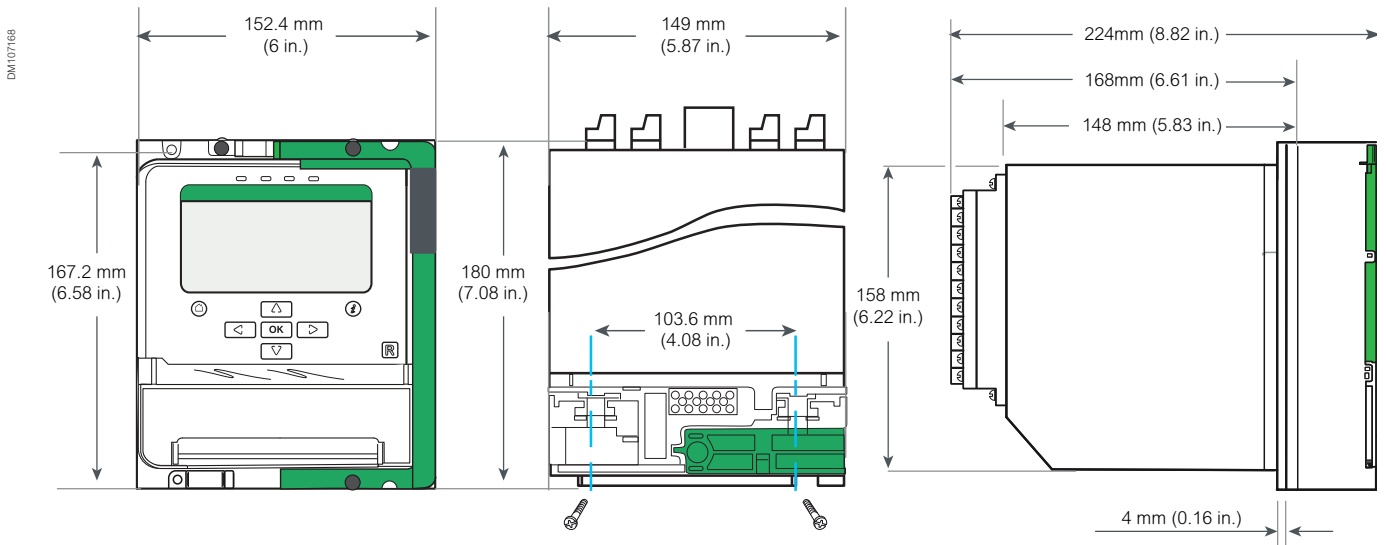

Flush mounting with accessory

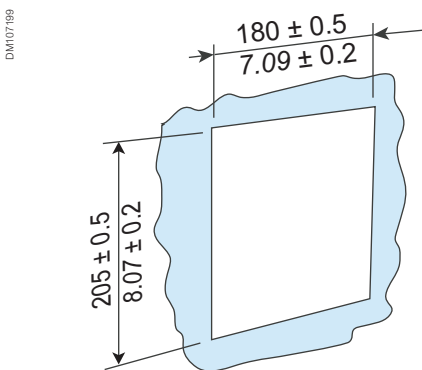

Cut-out dimensions	mm	in
Height	205 ± 0.5	8.07 ± 0.02
Width	180 ± 0.5	7.09 ± 0.02

Flush mounting without accessory

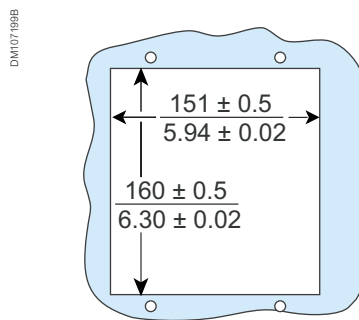

Cut-out dimensions	mm	in
Height	160 ± 0.5	6.30 ± 0.02
Width	151 ± 0.5	5.94 ± 0.02

More info on installation accessories [page 98](#)

NOTE 1: PowerLogic P5 relays can be mounted in rack. Please consult User Guide for more details.

NOTE 2: Please see the appropriate Safety Guide or User Guide for correct installation information.

CT and LPCT connection – slot A

Model with 3 phase CT + 2 residual CT inputs

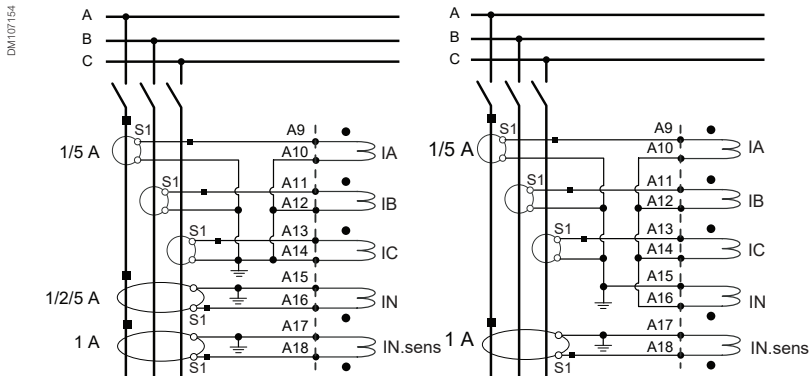

Model with 3 phase CT + 1 CSH inputs

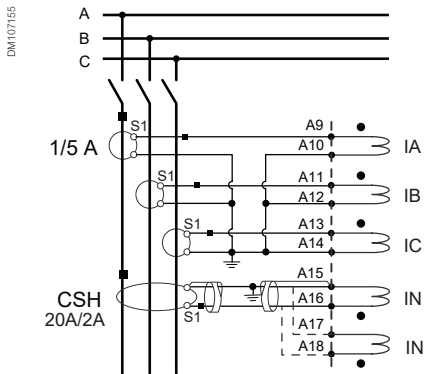

Model with 6 phase CT + 2 residual CT inputs

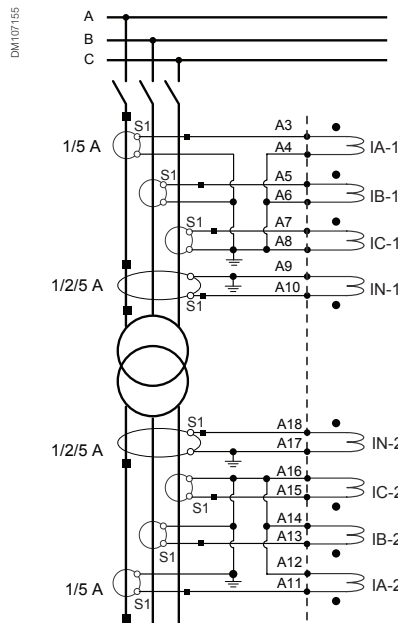

Model with 3 phase LPCT + 1 CSH inputs

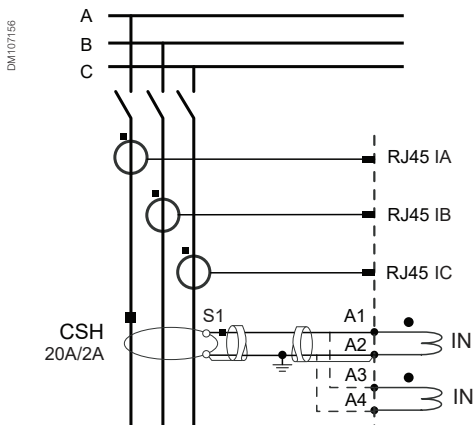

NOTE:
Please see the appropriate Safety Guide or User Guide for correct installation information.

Connection Diagrams

Voltage Transformers (and LPVT)

Slot A - VT and LPVT connection

Model with 4 VT inputs

3 phase-to-ground voltages
and 1 neutral voltage

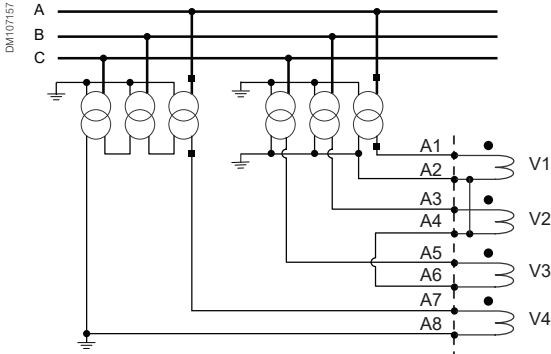

2 phase-to-phase voltages + 1 neutral voltage
+ 1 additional phase-to-phase voltage

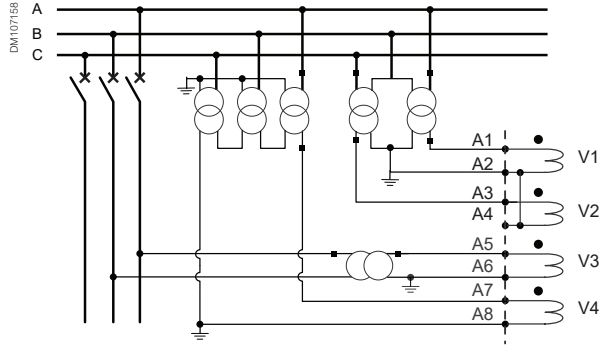

3 phase-to-ground voltages + 1 additional phase-to-phase voltage

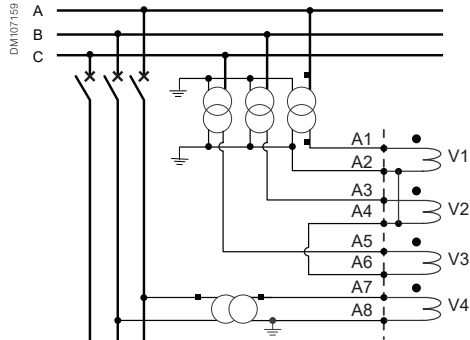

Model with 4 LPVT inputs

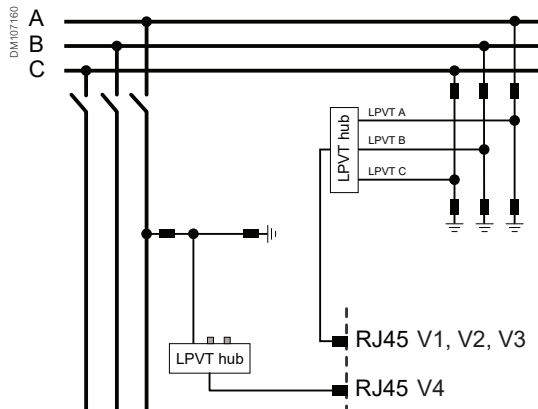

$V4 = V_B - V_A$ or
 $V4 = V_A$
according to setting

NOTE:
Please see the appropriate Safety Guide or User Guide for correct installation information.

Slot B - Power supply and digital I/O

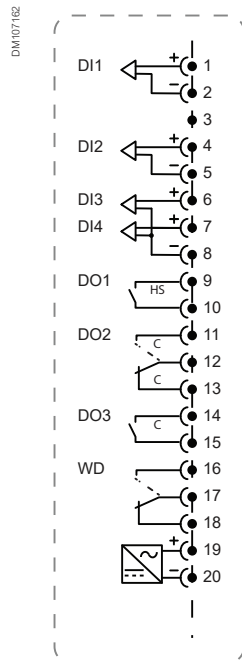
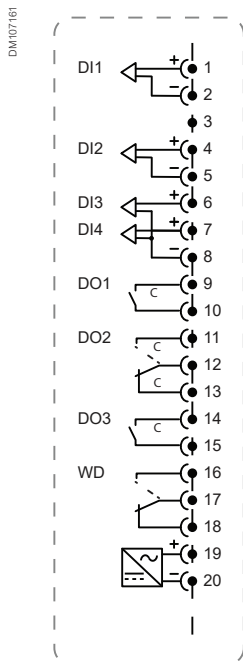

24 to 250 V supply
+ 4 DI + 3 DO + WD

DI1 to DI4:
universal digital inputs

DO1, DO2 and DO3:
control relay outputs

Watchdog (WD):
signaling relay output

48 to 250 V supply
+ 4 DI + 3 DO + WD
or
24 to 48 V supply
+ 4 DI + 3 DO + WD

DI1 to DI4:
universal digital inputs

DO1:
high-speed/high-break output
DO2 and DO3:
control relay outputs

Watchdog (WD):
signaling relay output

NOTE:
Please see the appropriate Safety Guide or User Guide for correct installation information.

Slot C - Additional digital I/O

P5x20 and P5x30

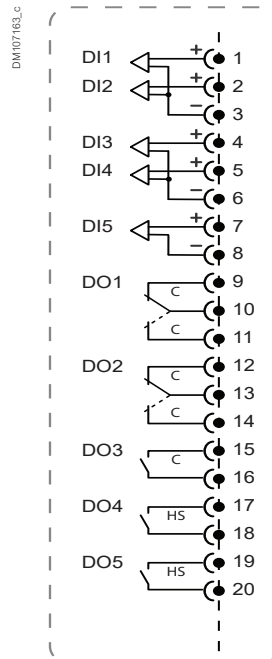
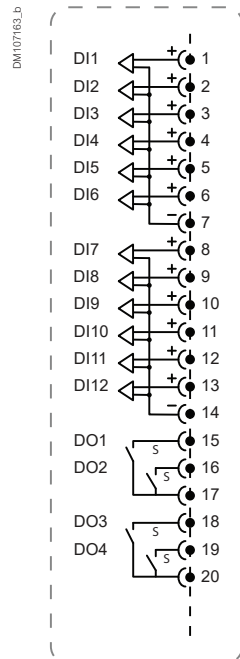
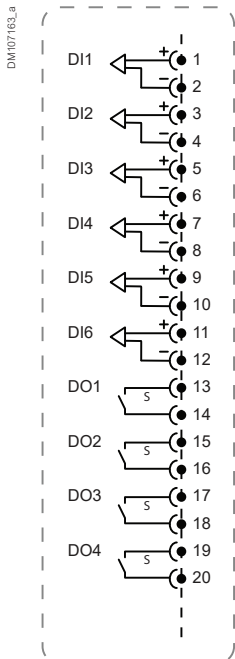

6 DI + 4 DO

DI1 to DI6:
universal digital inputs

DO1 to DO4:
signaling relay outputs

12 DI + 4 DO

DI1:
motor speed detection input ⁽¹⁾

DI2 to DI12:
universal digital inputs

DO1 to DO4:
signaling relay outputs

5 DI + 5 DO

DI1 to DI5:
universal digital inputs

DO1 to DO3:
control relay outputs

DO4 to DO5:
high-speed/high-break outputs

(1) DI1 can be used as universal input

NOTE:
Please see the appropriate Safety Guide or User Guide for correct installation information.

Slots D, E - Additional digital I/O and arc-sensors inputs

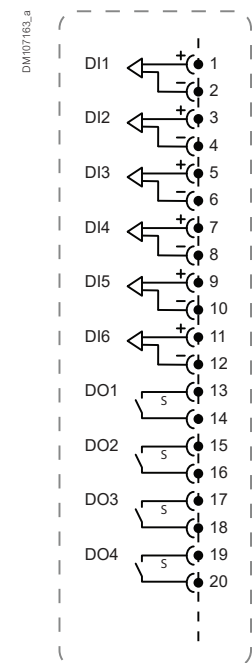

6 DI + 4 DO
DI1 to DI6:
universal digital inputs
DO1 to DO4:
signaling relay outputs

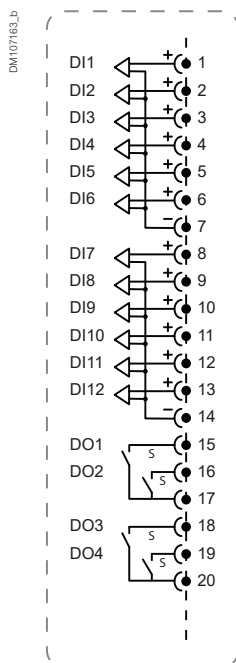

12 DI + 4 DO
DI1:
motor speed detection input ⁽¹⁾
DI2 to DI12:
universal digital inputs
DO1 to DO4:
signaling relay outputs

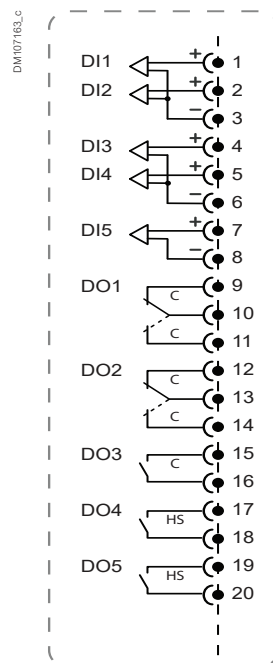

5 DI + 5 DO
DI1 to DI5:
universal digital inputs
DO1 to DO3:
control relay outputs
DO4 to DO5:
high-speed/high-break outputs

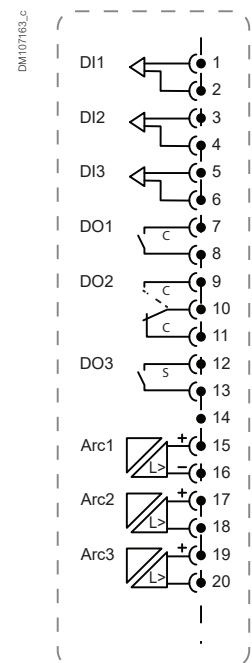

3 Arc + 3 DI + 3 DO
DI1 to DI3:
universal digital inputs
DO1 to DO2:
control relay outputs
DO3:
signaling relay outputs
3 point light sensor inputs

(1) DI1 can be used as universal input

NOTE:
For P5x30 the slot occupation rules apply. Follow the PowerLogic P5 Product Selector at se.com or consult the appropriate User Guide.
Please see the appropriate Safety Guide or User Guide for correct installation information.

Power supply		
Rated voltage	P5x20	24-250 Vdc; 100-230 Vac
	P5x30	24-48 Vdc 48-250 Vdc; 100-230 Vac
Variation		-20% / +20%
Typical burden ⁽¹⁾	P5x20	4 W ; 10 VA at 230 Vac
	P5x30	8 W ; 15 VA at 230 Vac
Maximum burden	P5x20	6 W ; 15 VA at 230 Vac
	P5x30	11 W ; 22 VA at 230 Vac
Maximum interruption time		100 ms
Measurement Inputs		
Rated frequency		50/60 Hz
Phase CT and standard earth/ground fault CT inputs		
Rated current		1 A / 5 A
Input impedance		< 0.02 Ohm
Thermal withstand, continuous		20 A
Thermal withstand, 1 s		500 A
Very sensitive earth/ground fault CT input		
Rated current		1 A
Input impedance		< 0.02 Ohm
Thermal withstand, continuous		4 A
Thermal withstand, 1 s		100 A
CSH input (for 470/1 dedicated sensors)		
Rated current		2 A / 20 A (primary value)
Input impedance		< 0.02 Ohm
Thermal withstand, continuous		300 A (primary value)
Thermal withstand, 1 s		20 kA (primary value)
LPCT inputs		
Rated voltage		22.5 mV
Extended rated voltage		0.25 to 31.5 rated voltage
Input impedance		2 MOhms / 500 pF
Thermal withstand		60 V
VT inputs		
Rated voltage		200 V
Input impedance		> 100 kOhms
Voltage withstand, continuous		1.2 rated voltage
LPVT inputs		
Rated voltage		3.25 V/√3
Extended rated voltage		0.25 to 1.5 rated voltage
Input impedance		10 MOhms / 15 pF
Thermal withstand		25 V

(1) According to configuration

Digital inputs

Rated voltage	240 V DC or AC
Switching threshold voltage	10 to 200 V, settable
Current drain	1 to 28 mA, settable ⁽¹⁾

Digital outputs (relays)

Control relay outputs

Rated voltage	240 V DC or AC
Continuous current	8 A
Making current	30 A, 200 ms
Breaking capacity (L/R < 40 ms)	50 W (24 to 127 V) / 30W (240 V) ⁽²⁾

Signaling relay output

Rated voltage	240 V DC or AC
Continuous current	2 A
Breaking capacity (L/R < 20 ms)	2 A (24 V) / 1 A (48 V) / 0.2 A (127 V) / 0.1 A (240 V)

High-speed and high-break output

Rated voltage	240 V DC or AC
Continuous current	10 A
Making current	30 A, 200 ms
Breaking capacity (L/R < 40 ms)	10 A (24 to 240 V)
Closing / opening time	1 ms / 200 ms

(1) According to configuration

(2) 50 W at 24 V with additional customer protection (RC or zener diode)

Electromagnetic compatibility	Standard	Level / Class	Value
Emission Tests			
Conducted emission	CISPR 11	Class A	0.15 to 0.5 MHz: 79 dB μ V (quasi peak)
	CISPR 32	Class A	0.5 to 30 MHz: 73 dB μ V (quasi peak)
	IACS E10		0.15 MHz to 0.3 MHz: 80 to 50 dB μ V/m
Radiated emission	CISPR 32	Class A	30 MHz to 230 MHz: 40 dB μ V (quasi peak) 0.3 MHz to 100 MHz: 60 to 54 dB μ V/m
	IACS E10		100 MHz - 2000 MHz, 54 dB μ V/m except for: 156 MHz - 165 MHz, 24 dB μ V/m
Immunity tests – radiated disturbances			
Electrostatic discharge	IEC 61000-4-2	Class 4	15 kV air / 8 kV contact
	ANSI C37.90.3		15 kV air / 8 kV contact
Radiated electromagnetic energy	IEC 61000-4-3	Level 3	10 V/m, 80 MHz to 2.7 GHz, 80% AM (1 KHz)
	ANSI C37.90.2		20 V/m, 80 MHz to 1 GHz, 80% AM (1 KHz)
	GOST 32137		10 V/m, 80 MHz to 1 GHz, 80% AM (1 KHz) and pulse 200 Hz
	GOST 30804.4.3		30 V/m, 800 to 960 MHz & 1.4 to 2 GHz
	IACS E10		10 V/m, 80 MHz to 1 GHz
Magnetic fields at power frequency	IEC 61000-4-8	Level 5	100 A/m continuous, 1000 A/m, 3 s
Pulse magnetic fields	IEC 61000-4-9	Level 5	1000 A/m
Oscillatory magnetic fields	IEC 61000-4-10	Level 5	100 A/m, 100 kHz and 1 MHz, 2 s
Immunity tests – conducted disturbances			
Radio frequency disturbances	IEC 61000-4-6	Level 3	10 V CM, 0.15 MHz to 80 MHz
Slow damped oscillatory waves	IEC 61000-4-18	Level 3	2.5 kV CM, 1 kV DM, 100 kHz & 1 MHz
	ANSI C37.90.1		2.5 kV, 1 MHz, CM and TM
	IEC 61000-4-12 GOST30804.4.12		2 kV CM, 1 kV DM, 100 kHz Source impedance: 12 Ω
Fast damped oscillatory waves	IEC 61000-4-18	Level 3	2 kV CM, 3MHz, 10MHz, 30MHz
Conducted disturbances 0 to 150 kHz	IEC 61000-4-16	Level 4	300 V CM, 150 V DM, 0 to 150 kHz 30 V, continuous at power frequency
Electrical fast transient or burst	IEC 61000-4-4	Level 4	4 kV CM, 5 kHz and 100 kHz
	ANSI C37.90.1		4 kV, 5 kHz CM and TM
	IACS E10		2 kV power supply, 1 kV digital I/Os, 5min
Surge	IEC 61000-4-5	Level 4	4 kV CM, 2 kV DM Communication ports: 2 kV CM, 1 kV DM

Other Characteristics

Safety	Standard	Value
General safety		IEC 60255-27
Creepage distances and clearances	IEC 60255-27	Pollution degree 2 overvoltage category III
High voltage withstand	IEC 60255-27	2 kV rms, 1mn 1 kV rms, 1mn across opened contacts
	ANSI C37.90	1.5 kV rms 1 mn across opened contacts of control relays
Impulse voltage withstand	IEC 60255-27	5 kV, 1.2 µs/50 µs
Insulation	IEC 60255-27	Insulation resistance > 100 MΩ at 500 Vdc

Electromagnetic compatibility	Standard	Level / Class	Value
Disturbances on the power supply			
Voltage dips	IEC 61000-4-11		0%, 5/6 cycles min
			40%, 10/12 cycles
			70%, 25/30 cycles
	IEC 61000-4-29		0%, 100 ms min
			40%, 200 ms
			70%, 500 ms
Interruption	IEC 61000-4-11		0%, 250/300 cycles
	IEC 61000-4-29		0%, 5 s
Voltage variations	IEC 61000-4-14	Class 3	±12 % Un
Frequency variations	IEC 61000-4-28	Level 4	±15 % of frequency variation
Ripples	IEC 61000-4-17		15%, 100 Hz to 120 Hz
Gradual shutdown	IEC 61000-4-27		
Reverse of DC power supply	IEC 61000-4-27		

AM : Amplitude Modulation / CM : Common Mode / DM : Differential Mode / TM : Transversal Mode

Enclosure	Standard	Level / Class	Value
Local panel	IEC 60529	IP54	Front panel
		IP54	Mounted in panel with flush mounting accessory
		IP41	Mounted without flush mounting accessory
	NEMA	Type 12	-
Rear panel	IEC 60529	IP10	Area with ring terminal connection (analogue inputs)

Base Unit Description

Other Characteristics

Mechanical robustness	Standard	Level / Class	Value
In operation			
Vibrations	IEC 60255-21-1	Class 2	1 Gn, 10 Hz to 200 Hz
	GOST 17516.1		0,015 mm peak, 0,5 Hz to 57,6 Hz 1 Gn 57,6 Hz to 150 Hz
	IACS E10		13.2 Hz to 100 Hz – acceleration ± 0.7 g
Shocks	IEC 60255-21-2	Class 2	10 Gn / 11 ms
Earthquakes	IEC 60255-21-3	Class 2	2 Gn horizontal / 1 Gn vertical
De-energized			
Vibrations	IEC 60255-21-1	Class 2	2 Gn ; 10 Hz - 150 Hz
Shocks	IEC 60255-21-2	Class 2	30 Gn / 11 ms
Jolts	IEC 60255-21-2	Class 2	20 Gn / 16 ms

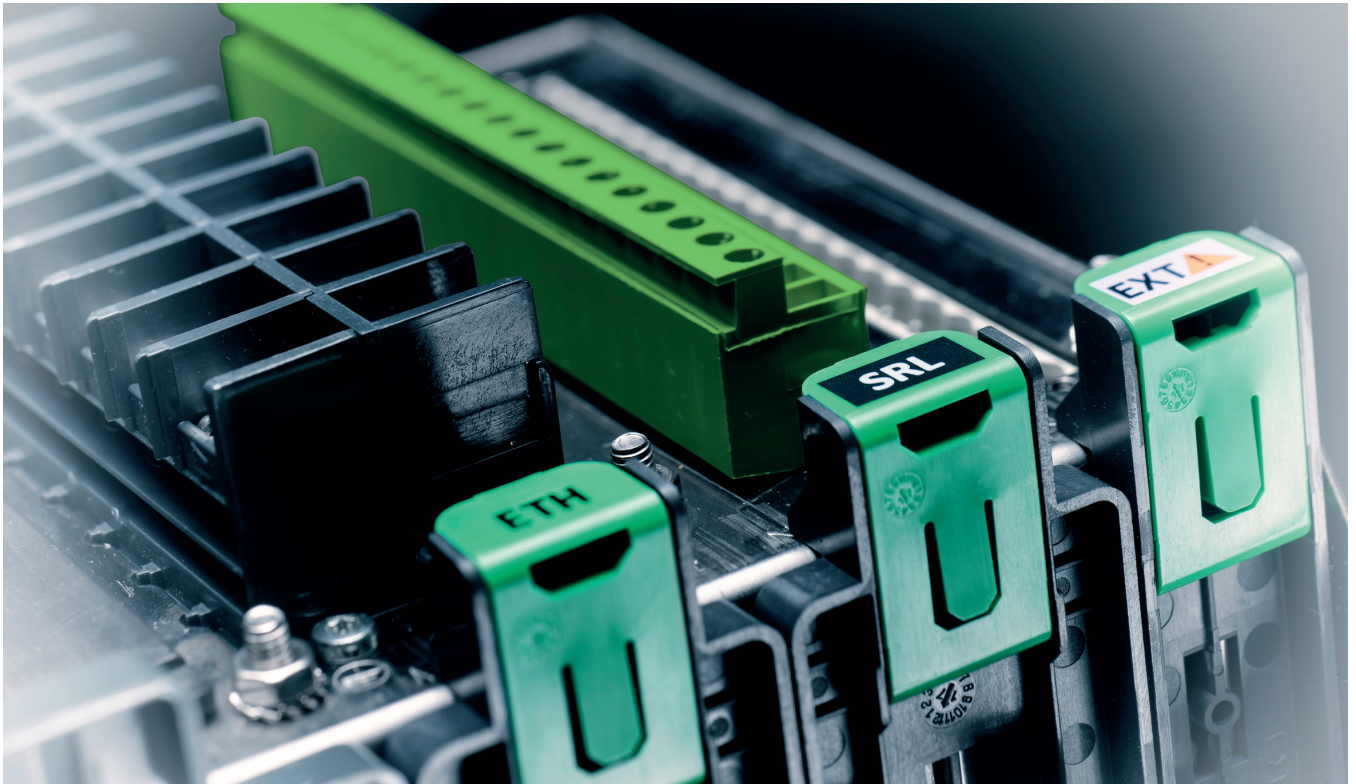

Base Unit Description





Other Characteristics

Climatic withstand	Standard	Level / Class	Value
In operation - Operating condition: -40°C to +70°C (-40°F to +158°F)			
Operating conditions			-40°C to +70°C (-40°F to +158°F)
Exposure to cold	IEC 60068-2-1	Ad	-40°C (-40°F) ; 96 h
Exposure to dry heat	IEC 60068-2-2	Bd	+70°C (+158°F), 96 h +85°C (+185°F), 16 h
Exposure to damp heat	IEC 60068-2-78	Cab	93% RH without condensation, 40°C (104°F), 56 days
	IEC 60068-2-30	Db	93-95% RH, 25°C to 55°C (77°F to 131°F), 6 cycles (12 + 12 hours)
Temperature variation	IEC 60068-2-14	Nc	-40°C to +70°C (-40°F to +158°F) 10°C/mn (18°F/mn)
In storage			
Storage conditions			-40°C to +85°C (-40°F to +185°F)
Exposure to cold	IEC 60068-2-1	Ab	-40°C (-40°F) ; 96 h
Exposure to dry heat	IEC 60068-2-2	Bb	+85°C (+185°F) ; 96 h
Exposure to damp heat	IEC 60068-2-78	Cab	93% RH to 95% RH, 40°C (104°F), 56 days
Corrosive atmosphere			
Salt mist	IEC 60068-2-52	Kb / 1	
Corrosive 2 and 4 gas tests	IEC 60068-2-60	Ke	<ul style="list-style-type: none"> Method 1; 0,5 ppm H₂S; 1 ppm SO₂ Method 4; <ul style="list-style-type: none"> 0,071 ppm H₂S, 0,26 ppm NO₂, 0,034 ppm Cl₂, 0,11 ppm SO₂
	IEC 60721-3-3	3C2	21 days

Cybersecurity

	Standard
Certification	Achilles, Level I
Certificate number	453-071119
Certification	Achilles, Level II
Certificate number	500-101420
Certification	IEC 62443 4-2 Security Level 1
Certificate number	968/FSP 2168.00/21

Marking and homologations

Standard	Value	
EN 60255-27 EN 60255-26 EN IEC 63000	LV Directive 2014/35/EU EMC Directive 2014/30/EU RoHS Directive 2011/65/EU incl. 2015/863/EU	
UL508 ANSI/IEEE C37.90 CAN/CSA C22.2 No.14	File E354250, NRGU	
EAC Eurasian Customs Union	Certificate number: EA3C RU C-FR.HA46.B.05269/22	
BS EN 60255-27 BS 60255-26 BS EN IEC 63000	SI 2016 No. 1101 SI 2016 No. 1091 SI 2012 No. 3032	

Digital Experience

Digital Experience

Set Up Software	82
eSetup Easergy Pro	82
eSetup Easergy Pro - during engineering	83
eSetup Easergy Pro - during commissioning	83
eSetup Easergy Pro - during operation	83
<hr/>	
Web-HMI	84
<hr/>	
Mobile Application	85
<hr/>	

Set Up Software

eSetup Easergy Pro



At every step of the digital life

eSetup Easergy Pro offers full facilities to set up PowerLogic Px protection relays. Intuitive and simple, eSetup Easergy Pro is a user-oriented interface to assist you during the engineering, commissioning and operation of PowerLogic Px protection relays. Its streamlined workflow and graphical representations have been designed to simplify your configuration process.

The software is available for download on the Schneider Electric website.

Minimum requirements for running eSetup Easergy Pro:

- Windows 7 or higher
- 512 MB RAM
- 50 MB Disk space

eSetup Easergy Pro can run autonomously or can be run inside eSetup PowerLogic Studio software.

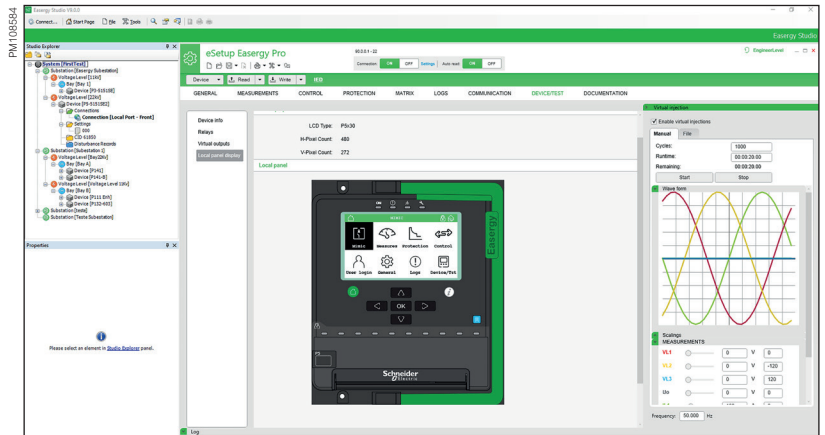

The User can benefit from a single configuration interface for PowerLogic Px, PowerLogic MiCOM and MiCOM protection relays with an electrical system structure view. The integration of PowerLogic Px protection relays in complex projects is now quick and easy.

How to use eSetup Easergy Pro?

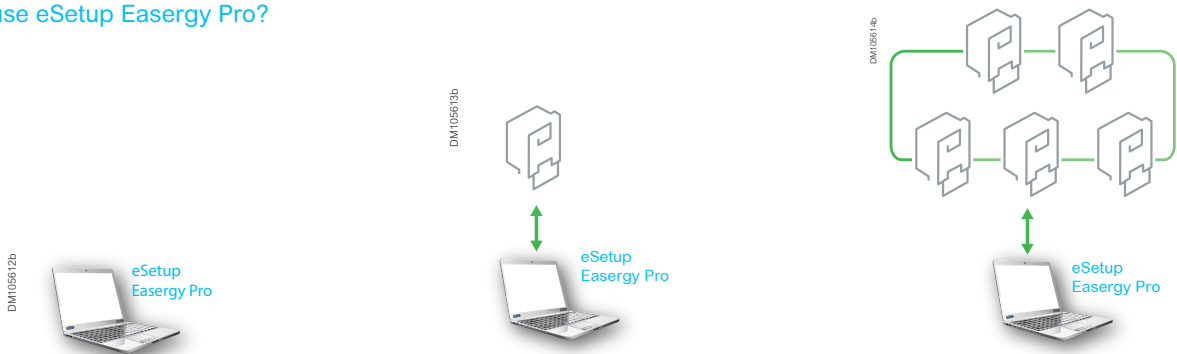

Use eSetup Easergy Pro in standalone mode during engineering to prepare the configuration.

Connect the PC running eSetup Easergy Pro to the USB port of the PowerLogic P5 protection relay during commissioning to adjust the settings and test the protection relay.

For connection to PowerLogic P5, use the connection cord ref: 59700

Connect the PC running eSetup Easergy Pro to the Ethernet network during operation to retrieve data from the protection relays and update the system.

Set Up Software

eSetup Easergy Pro

During engineering

- Create the configuration of the PowerLogic P5 relay: select the appropriate options and receive the model number.
- Set the characteristics of the CTs, VTs, or sensors connected to the relay, and select the protection functions that will be activated and their settings.
- Build a specific logic equations file, if required, using a graphical editor.
- Map the digital inputs of the relay and different internal signals to the relevant functions, LEDs, and digital outputs, using a straightforward matrix format.
- Draw the single-line diagram that will appear on the front display of the relay for switchgear control and select the measurements that will be displayed. If required, build the interlocking logic using a matrix format.
- Compare your configuration files with other files or with the actual configuration of your device.
- Save or load your file with version control (track the changes and manage the versions of the file).
- For IEC 61850 protocol, configure the data set and the report control blocks that will be published and select the GOOSE data to which you want to subscribe.
- Complete the setting of additional functions (disturbance recorder, event logging system, clock synchronization, etc.).
- Use the Script File function to upload standard configuration in a few seconds.
- Deploy your offline setting file to many devices.

During commissioning

- Connect to the front panel of one single relay or access several relays by connecting to Ethernet.
- Open the Digital Inputs menu to check the status of inputs. Reverse the polarity or add a filtering delay if necessary.
- Open the Relays menu and force the status change of the output relays in order to check the wiring.
- Open the Phasor Diagram menu to see in real time the injected currents and voltages and the value.
- Use virtual injection for testing protection settings and circuit breaker tripping and for checking LEDs and connected outputs.
- Monitor the logic execution online and apply the changes in logic or in the matrix.
- Compare your configuration file with the configuration in the relay.

During operation

- Connect to the front panel of a single relay or gain access to several relays by connecting to Ethernet
- During normal operation, get the most of the metering capabilities of the PowerLogic protection relay:
 - Open the different Measurements menus to access the power monitoring and power quality data.
 - Open the disturbance recorder menu to get a waveform capture or program the recording of a power trend.
- After a trip, use eSetup Easergy Pro to understand the fault:
 - Check the fault log of the protection that has tripped the circuit breaker
 - Download the disturbance record from the PowerLogic P5 and display it with a disturbance recorder evaluation tool, eg. Wavewin.
- Benefit from safe file download with all data required to analyse network events.

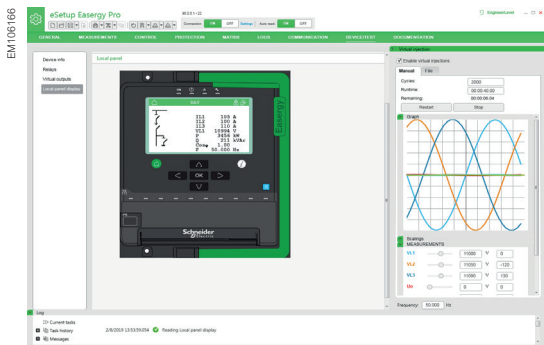
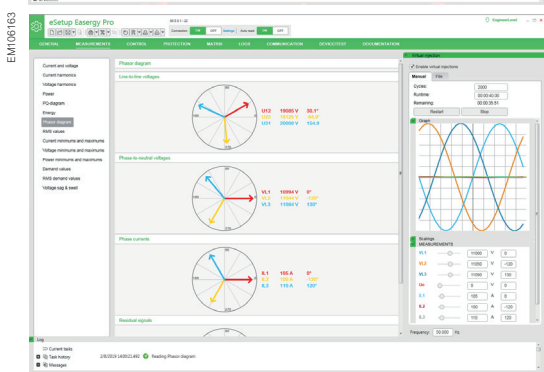
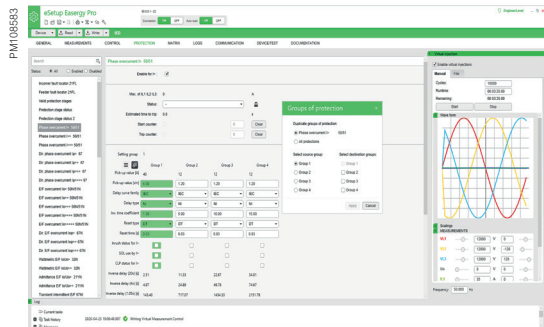
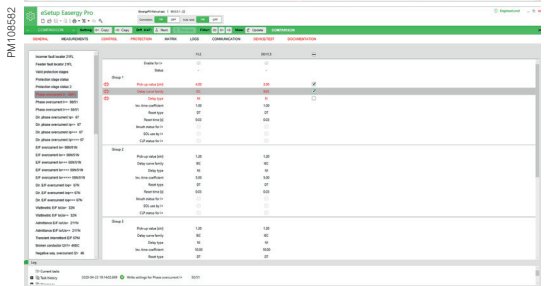
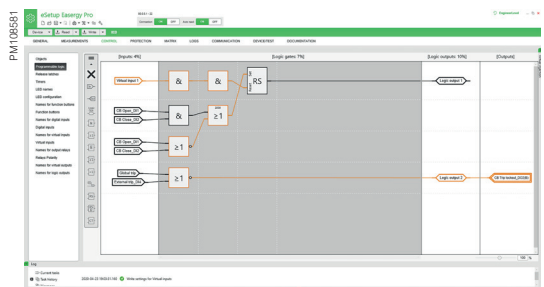

Enhance operational efficiency

- Direct access to protection and communication settings
- Control and monitoring of circuit breakers and switches
- Mirror HMI function
- Direct access to measurements including graphical phasor diagrams
- Device diagnosis
- MATRIX status
- Access to logs and other information

Boost operational efficiency with the embedded web-HMI

Quickly and conveniently configure, monitor, and operate your PowerLogic P5 protection relay with our web-HMI. The web-HMI, accessible online via the IP address of the relay, doesn't require you to install specific computer software - simply use your web browser to connect to the device. You just need to enable the web server service during the initial configuration of PowerLogic P5 with eSetup Easergy Pro. The web-HMI is based on the same page design as eSetup Easergy Pro, making it easy to use!

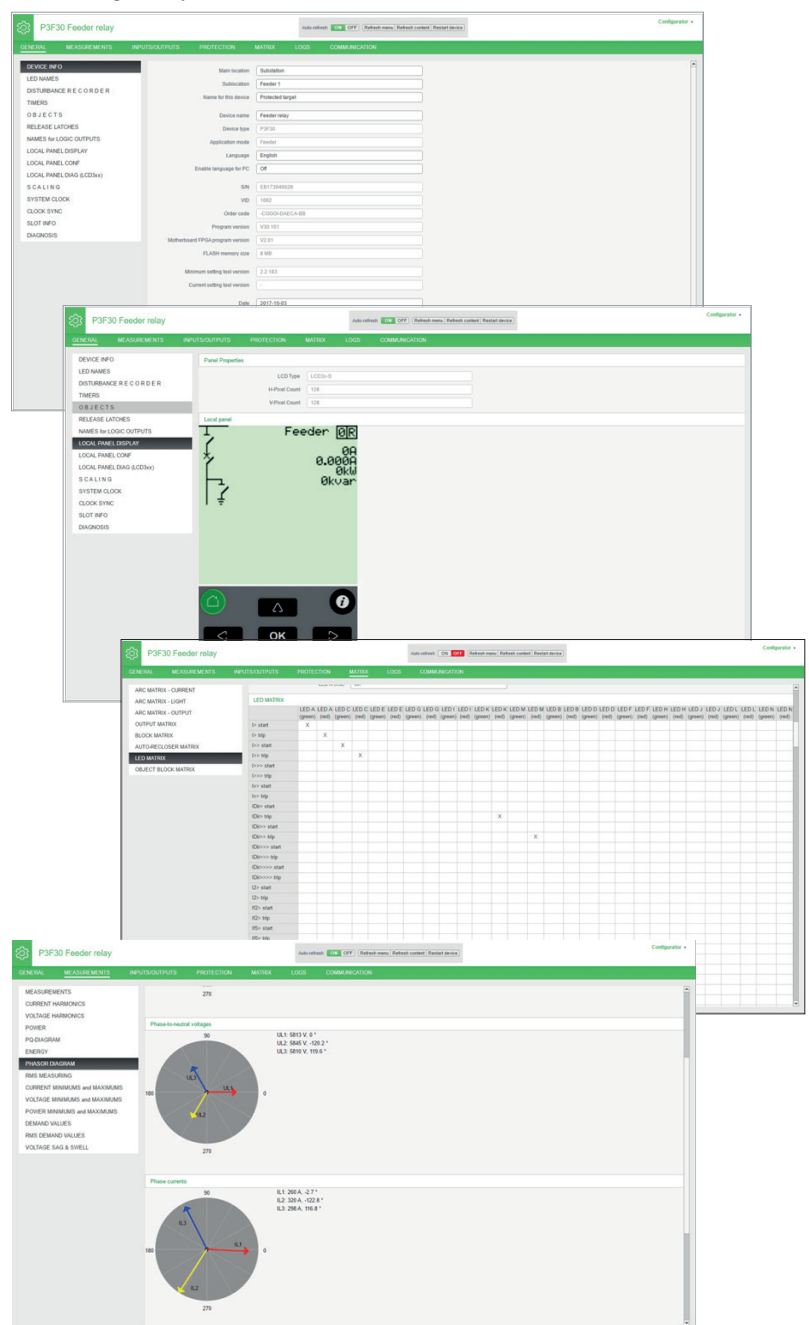

Mobile Application

Description



EcoStruxure™ Power Device app

Within the palm of your hand you can be connected to your Schneider Electric:

- Masterpact MTZ air circuit breaker
- TeSys GV4 motor circuit breaker
- PowerLogic P5 protection relays
- ... and more!

EcoStruxure Power Device app is a single mobile application with necessary information and capabilities to operate and efficiently maintain devices in the EcoStruxure architecture.

This app can be installed on your IOS and Android smartphone. The protection devices can be identified on the app by simply scanning their QR codes.

Wireless communication is possible via by WIFI⁽¹⁾, Bluetooth⁽²⁾, NFC⁽²⁾ technologies for operation and monitoring within the proximity of the devices. Get real time notifications about the electrical installation: load levels, health status, warnings and alarms, protection settings...and more!

Free download

EcoStruxure Power Device on:



(1) WIFI is not embedded in PowerLogic P5, a separate WIFI router connected to an Ethernet port of the device is required.
(2) Contact Schneider Electric for availability.

Additional Modules and Accessories

Additional Modules and Accessories

Communication Accessories	88
Modules	88
Other Accessories	94
Extension Modules	94
Low Power Instrument Transformer Accessories	95
Sensors	98
Arc-flash Sensors	99
Mounting Accessories	100

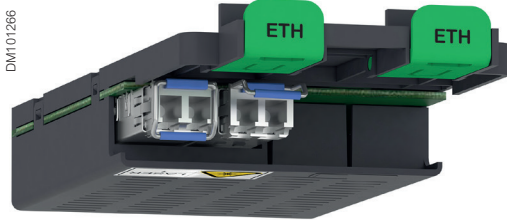

Ethernet HSR/PRP FO module

Ethernet communication module with HSR and PRP redundancy

REL51033: Ethernet HSR/PRP FO module

The Ethernet communication module with HSR or PRP redundancy and PTP according to IEEE 1588v2 is inserted in both slots M and N of the PowerLogic P5. The module can be selected as an option when ordering the PowerLogic P5 or purchased later and installed on site. This module requires fiber optic connection.

In addition to relay communication protocols on Ethernet, it also enables the use of PRP (Parallel Redundancy Protocol) and HSR (High-availability Seamless Redundancy) – selectable by configuration, which allow instantaneous reconfiguration of the communication system without communication packet loss. On the top of this PTP (Precision-Time-Protocol) is available that allows for time synchronization with an accuracy of less than 1 ms.

Characteristics

Standard	2 ports: 100 Base FX	
Baud rate	100 Mbits/s	
Fiber type	Multimode glass fiber	
Wavelength	1300 nm	
Connection	LC	
Maximum attenuation (fiber optic + connectors)	Fiber optic diameter	Max attenuation
	50/125 or 62.5/125 µm	14 dB

Back-up power supply input

Rated voltage	12VDC ±20%
Burden	0.5 W
Dielectric withstand	500V, 50Hz, 1 mn



HAZARD OF DAMAGE TO THE EYES

Never look into the end of a fiber optic or connectors of the module

Failure to follow these instructions will result in death or serious injury.

Ethernet communication module with RSTP redundancy

The Ethernet communication module is inserted in slot M of PowerLogic P5. The module can be selected as an option when ordering the device or purchased later and installed on site. This module is available in 2 versions for copper wire or fiber optic connection.

In addition to relay communication protocols on Ethernet, it also enables the use of RSTP (Rapid Spanning Tree Protocol), which allows fast reconfiguration of the communication system. If redundancy is not required, it can expand communication capabilities by offering Dual IP feature.

DM101266

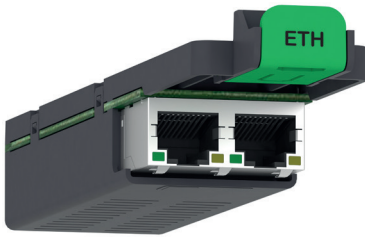

Ethernet TP module

REL51038: Ethernet TP module

Characteristics

Standard	2 ports: 10/100 Base TX
Baud rate	10 or 100 Mbits/s
Type of cable	Standard Ethernet CAT 5
Connection	RJ45

DM101267

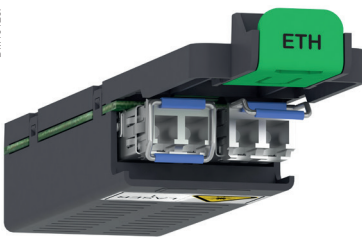

Ethernet FO module

REL51039: Ethernet FO module

Characteristics

Standard	2 ports: 100 Base FX	
Baud rate	100 Mbits/s	
Fiber type	Multimode glass fiber	
Wavelength	1300 nm	
Connection	LC	
Maximum attenuation (fiber optic + connectors)	Fiber optic diameter	Max attenuation
	50/125 or 62.5/125 μ m	14 dB



DANGER

HAZARD OF DAMAGE TO THE EYES

Never look into the end of a fiber optic or connectors of the module

Failure to follow these instructions will result in death or serious injury.

Second Ethernet communication module with RSTP redundancy

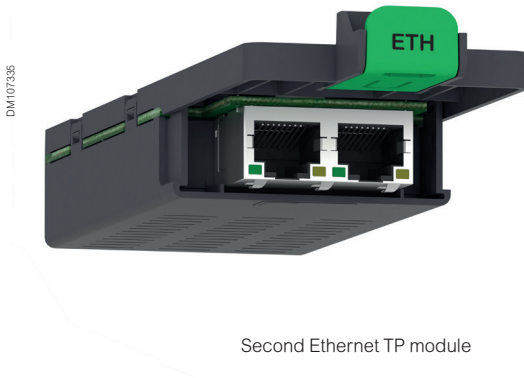

REL51042: Second Ethernet TP module

The second Ethernet communication module is inserted in slot L of PowerLogic P5x30. It can be selected as an option when ordering the device or purchased later and installed on site. This option maximises the application flexibility for advanced network architectures.

In addition to relay communication protocols on Ethernet, it also enables the use of RSTP protocol which allows fast reconfiguration of the communication system. In combination with first Ethernet communication modules it provides dual redundancy capability.

Characteristics

Standard	2 ports: 10/100 Base TX
Baud rate	10 or 100 Mbits/s
Type of cable	Standard Ethernet CAT 5
Connection	RJ45

Serial line communication module

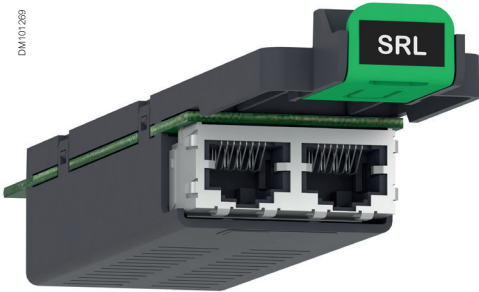

RS485 serial line module

REL51036: RS485 serial line module

The serial line communication module is inserted in the slot N of the PowerLogic P5. The module can be selected as an option when ordering the PowerLogic P5 or purchased later and installed on site. This module is available in two versions for RS485 or fiber optic connection.

Characteristics

Standard	EIA 2-wire RS485 differential or EIA 4-wire RS485 differential (selection by configuration)
Line polarization	12V, internally provided
Connection	2x RJ45 – pin-out as follows: <ol style="list-style-type: none"> 1. RXD0 2. RXD1 4. TXD1 (D1) 5. TXD0 (D0) 8. Common

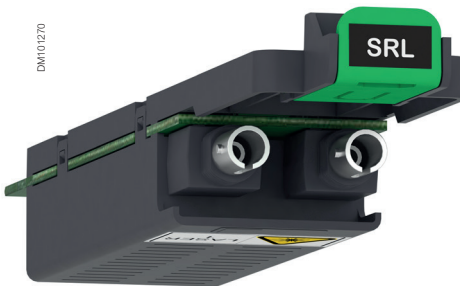

Fibre optic serial line module

REL51040: Fiber optic serial line module

Characteristics

Fiber type	Multimode glass fiber (HSC)	
Wavelength	820 nm	
Connection	ST	
Maximum attenuation (fiber optic + connectors)	Fiber optic diameter	Max attenuation
	50/125 µm	5.6 dB
	62.5/125 µm	9.4 dB
	100/140 µm	14.9 dB
	200 µm	19.2 dB



HAZARD OF DAMAGE TO THE EYES

Never look into the end of a fiber optic or connectors of the module

Failure to follow these instructions will result in death or serious injury.

Extension module

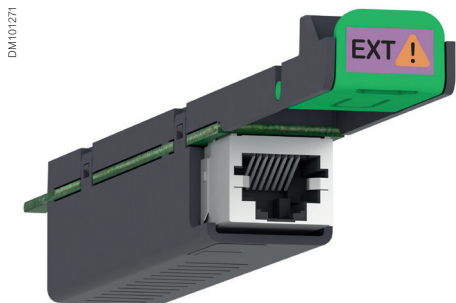

Extension module

REL51034: Extension module

The extension module is inserted in the slot P of PowerLogic P5. The extension module can be selected as an option when ordering the PowerLogic P5 or purchased later and installed on site. This module provides:

- connection to the external modules
- automatic back-up of data:
 - active configuration file and all four setting groups parameters
 - disturbance records
 - motor-startup records (when available)
 - sequence of events records
 - power system maintenance data log
 - maintenance data of circuit-breaker, switches, motor and transformer (whichever available)

Characteristics

Connection	RJ45
Type of cable	Specific cables have the following references: <ul style="list-style-type: none">• 59660: length 0.6 m• 59661: length 2 m• 59662: length 4 m



IRIG-B module

REL51045: IRIG-B module

The IRIG-B module is an external module used for accurate time synchronization. It is connected to the extension module. It can be selected as an option when ordering the device or purchased later and installed on site. The module provides both a modulated (MOD INPUT) and an unmodulated input (UNMOD INPUT) and can automatically detect which input type is used by the user. No configuration of input type is needed in the PowerLogic P5 protection relay.

It does not require any auxiliary supply connection.

Mechanical characteristics

Assembly	Symmetrical DIN rail
----------	----------------------

Modulated IRIG-B input

Connection	BNC socket
Type of cable	50 ohm coaxial
Time code format	B124, B125 (1)
Input signal level	200mV to 20V

Demodulated IRIG-B input

Connection	Screw-type terminals
Type of cable	Twisted pair
Time code format	B004, B005 (1)
Input signal level	TTL

(1) according to standard 200-04

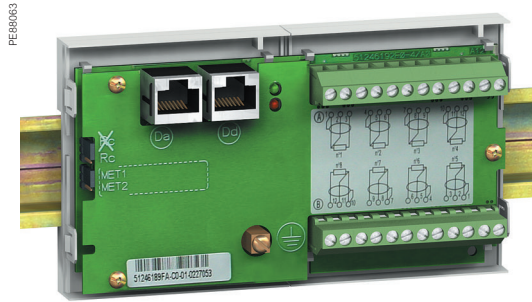

Temperature sensor module

59641: Temperature sensor module

The Temperature sensor module is an external module used for temperature measurement with Resistance Temperature Detectors (RTDs). It is connected to the extension module. It can be selected as an option when ordering the device or purchased later and installed on site. It provides 8 RTD inputs.

It does not require any auxiliary supply connection.

Mechanical characteristics

Assembly Symmetrical DIN rail

RTD input

Connection	Screw-type terminals
Type of cable	Shielded cable
Type of RTD	Pt100, Ni100, Ni120
Current injected in the RTD	4 mA

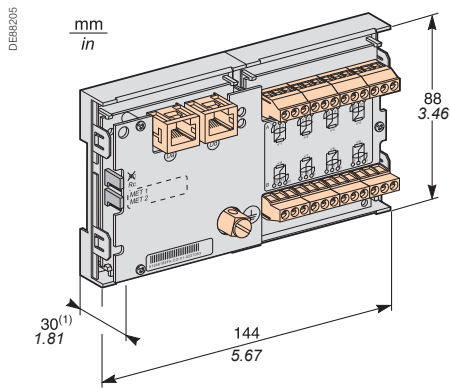

Other Accessories

Low Power Instrument Transformer Accessories

LPVT hub connector

PM106120



EMS59573: LPVT hub connector

The LPVT hub connector is a simple passive device that combines three LPVT signals coming from 3 different connectors into one single RJ45 connections.

The output of the LPVT hub connector is directly connected to the LPVT input of the PowerLogic P5 protection relay.

This accessory is indispensable when connecting PowerLogic P5 protection relays to LPVTs. It has to be ordered separately to PowerLogic P5 protection relay.

Characteristics

Input voltage	< 10 V
Input voltage limits	< 30 V
Network frequency	50/60 Hz
Electrical connection	output: RJ45 connector inputs: 3 x RJ45 connectors
Dimension (L x W x H)	95 x 40 x 40 mm (3.74 x 1.57 x 1.57 in)
Weight	0.25 kg (0.55 lb)
Mounting support	DIN Rail
Operating altitude	≤ 3000 m (1.86 miles)

Voltage adapter

PM106126



EMS59572: Voltage adapter

The voltage transformer adapter is made with 4 resistor bridges used to interface conventional voltage transformers (VTs) with the PowerLogic P5 protection relay equipped for LPCT/LPVT sensors. It has to be ordered separately to PowerLogic P5 protection relay.

Characteristics

Input voltage	50 Vac to 200 Vac (line-to-line)
Voltage max	600 V max permanent
Network frequency	50/60 Hz
Weight	0.15 kg (0.33 lb)
Mounting support	Symmetrical DIN Rail

Other Accessories

Low Power Instrument Transformer Accessories

LPVT transducer

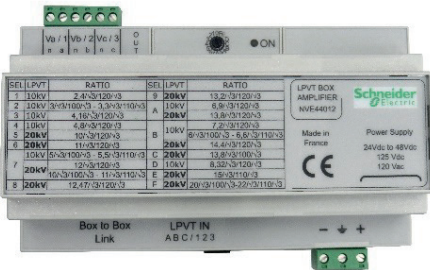

P7M12025: LPVT transducer

The LPVT Transducer allows an accurate transmission of the low voltage output signal from LPVT sensors (3.25/ $\sqrt{3}$ V) across up to ten PowerLogic P5 protection relays equipped with LPVT measuring inputs. The low voltage input is provided through a single RJ45 connector that brings the 3 phase LPVT signals merged by LPVT hub connector EMS59573. P7M12025 can be installed on DIN rails complying with EN/IEC 60715.

The connections between all the elements are done with RJ45 wires that can be ordered with commercial references: 59660 (0.6 m) 59661 (2 m), 59662 (4 m). The branching between LPVT bus and each PowerLogic P5 protection relay is done with a 3-way RJ45 junction box (T-box) REL51095.

Characteristics

Nominal voltage input / output	1.876 V (3.25/ $\sqrt{3}$ V) / 1.876 V (3.25/ $\sqrt{3}$ V)
Voltage factor	1.2 nominal voltage continuously 1.9 nominal voltage for 8 hours
Accuracy	Measurement class 0.5 Protection class 3P Input burden 10 M Ω // 2.2 pF For -5°C to +40°C
Power supply	24 to 48 Vdc, 125 Vdc or 120 Vac
Operating temperature	-25°C to +70°C
Dimensions (L x W x H)	160 x 60 x 90 mm (6.30 x 2.36 x 3.54 in)

LPIT Test Box

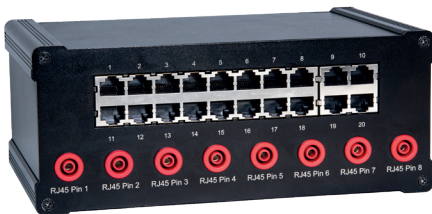

REL51037: LPIT test box*

This LPIT Test Box is an adapter for secondary testing of PowerLogic P5 protection relays with LPCT/LPVT measuring inputs. It's an interface between Omicron testing kit's low-power outputs and PowerLogic P5 inputs. Thanks to this adapter the testing is comfortable and the right accuracy in the entire measuring range is ensured. For the LPCT signal testing the LPIT Test Box offers 4 sets of current and 2 sets of voltage outputs depending on the measuring ranges tested.

The LPIT test box is delivered with all cables required to perform the tests.

Characteristics

Nominal LPCT voltage input / output	1 V / 22.5 mV, 2 V / 22.5 mV, 2 V / 225 mV and strait
Nominal LPVT voltage input / output	1.876 V (3.25/ $\sqrt{3}$ V) / 1.876 V (3.25/ $\sqrt{3}$ V)
LPCT testing ranges	0.35 to 3.50 pu 0.70 to 7.00 pu 3.50 to 35.00 pu
Accuracy	Typically 0.2%
Operating temperature	0°C to +50°C
Dimensions (L x W x H)	208 x 124 x 85 mm (8.19 x 4.88 x 3.35 in)

*Please contact Schneider Electric for availability.

Other Accessories

Low Power Instrument Transformer Accessories

LPCT Test Socket and Plug



REL51089: LPCT Test Socket Essailec® (incl. cover)*

REL51090: LPCT Test Plug Essailec®*

The LPCT test sockets and plugs Essailec® from TE Connectivity allow to test PowerLogic P5 protection relay with LPCT measuring inputs in a comfortable way, profiting from RJ45 cable connections. The test procedure is exactly the same as for protection relays with conventional CT measuring inputs. The test socket is installed on the front panel of medium voltage switchgear interconnecting the LPCTs and PowerLogic P5 protection relay. When the test plug is connected, the current circuit opens and allows to inject the signals from testing kit.

The quality of signals is protected by screened cover and casing. Grounding connection of socket casing is provided. The solution is designed to limit human mistakes related to mixing of current and voltage circuits.

The LPCT Test Socket is delivered with a cover. LPCT test plug is required to perform secondary testing using a test socket that is installed in the medium voltage cubicle.

**Please contact Schneider Electric for availability.*

LPVT Test Socket and Plug



REL51092: LPVT Test Socket Essailec® (incl. cover)*

REL51093: LPVT Test Plug Essailec®*

The LPVT test sockets and plugs Essailec® from TE Connectivity allow to test PowerLogic P5 protection relay with LPVT measuring inputs in a comfortable way, profiting from RJ45 cables connections. The test procedure is exactly the same as for protection relays with conventional VT measuring inputs. The test socket is installed on the front panel of medium voltage switchgear interconnecting the LPVTs and PowerLogic P5 protection relay. When the test plug is connected, the voltage circuit opens and allows to inject the signals from testing kit.

The quality of signals is protected by screened cover and casing. Grounding connection of socket casing is provided. The solution is designed to limit human mistakes related to mixing of current and voltage circuits.

The LPVT Test Socket is delivered with a cover. LPVT test plug is required to perform secondary testing using a test socket that is installed in the medium voltage cubicle.

Characteristics

Casing	Polycarbonate UL94 V0
Conductive elements	Silver coating
Connection type	RJ45 (Cat.5)
Nominal voltage	125 V
Maximum voltage	1000 V
Pollution degree	3
Nominal current	1.5 A
Accuracy	0.5 A
Operating temperature	-40°C to +85°C
IP degree (without cover / with cover)	IP20 / IP40

**Please contact Schneider Electric for availability.*

CSH core-balance current transformers

The CSH120, CSH200 and CSH300 core balance CTs are especially designed for direct residual or earth/ground fault current measurement. The only difference between them is the diameter.

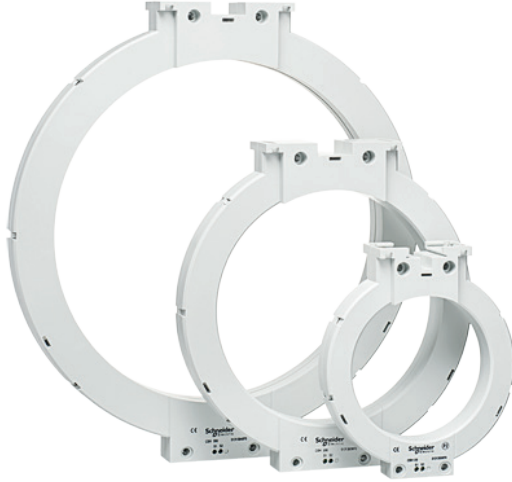

CSH120, CSH200 and CSH300 core balance CTs.

Core balance CT	59635: CSH120	59636: CSH200	59637: CSH300
Inner diameter	120 mm (4.72 in)	196 mm (7.72 in)	291 mm (11.46 in)
Weight	0.6 kg (1.32 lb)	1.4 kg (3.09 lb)	2.5 kg (5.51 lb)
Transformation ratio	1/470		
Maximum permissible current	20 kA - 1 s		

Dimensions

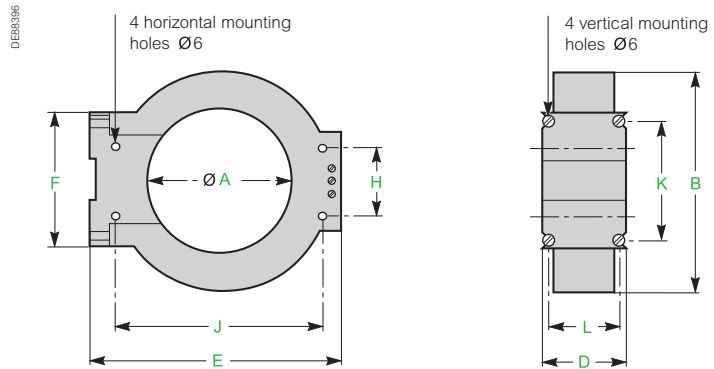

	59635: CSH120		59636: CSH200		59637: CSH300	
	mm	in.	mm	in.	mm	in.
A	120	4.72	196	7.72	291	11.46
B	164	6.46	256	10.1	360	14.17
D	44	1.73	46	1.81	46	1.81
E	190	7.48	274	10.8	390	15.35
F	80	3.15	120	4.72	120	4.72
H	40	1.57	60	2.36	60	2.36
J	166	6.54	254	10	369	14.53
K	65	2.56	104	4.09	104	4.09
L	35	1.38	37	1.46	37	1.46

Arc-flash Sensors

For PowerLogic P5x30 only

Sensors description

The sensors are used by the arc flash protection function (P5x30 models) to detect the light coming from the arc-flash incident.

The sensor is activated by strong light as found during arc flash incidents. The sensor transforms the light information into the current signal, which is used by the protection device to indicate arc-flash.

Arc-flash sensors	Standard						Pipe			
Characteristics	REL52801	REL52802	REL52803	REL52804	REL52805	REL52806	REL52807	REL52808	REL52809	REL52810
Material	Plastic									
Weight	1,000 g 2.20 lb	1,300 g 2.87 lb	1,300 g 2.87 lb	300 g 0.66 lb	400 g 0.88 lb	400 g 0.88 lb	1,000 g 2.20 lb	1,300 g 2.87 lb	300 g 0.66 lb	400 g 0.88 lb
Cable length (m)	20	20	20	6	6	6	20	20	6	6
Shielded cable	-	-	•	-	-	•	-	•	-	•
Halogen free	-	•	-	•	-	-	-	-	-	-
Environment	Pollution Degree 2									
Operation temperature	-25°C (-13°F) to +70°C (+158°F)									
Light spectrum sensitive area	400 – 1100 nm									
Detection time	1 ms									
Light sensitivity	8 000 – 10 000 lux									
Loop supervision	Yes									

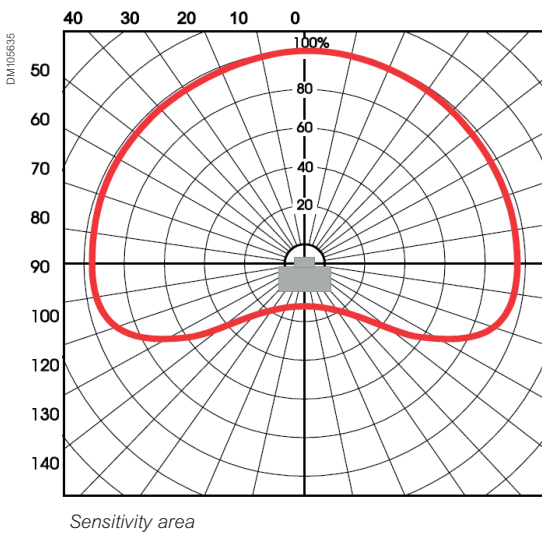

REL52801 - 52806 dimensions

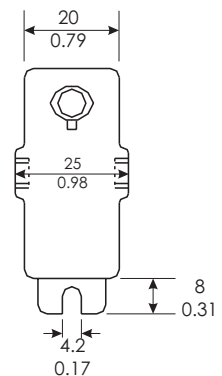
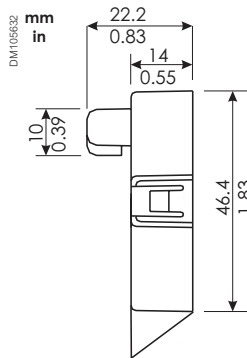

REL52807 - 52810 dimensions

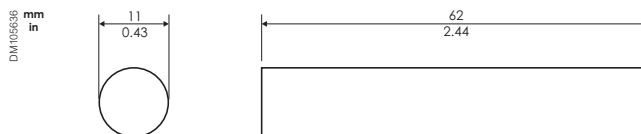

Arc-flash sensor: Pipe type

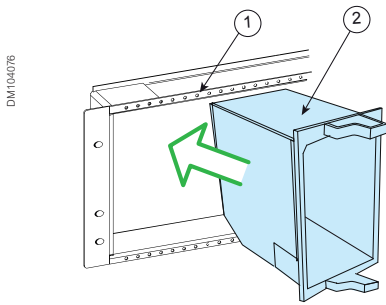

Assemble the case (2) and the rack frame (1)

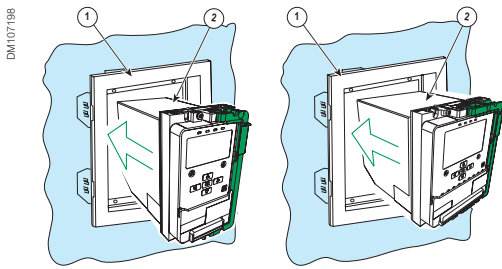

Assemble the flush mounting accessory (1) and the case (2)

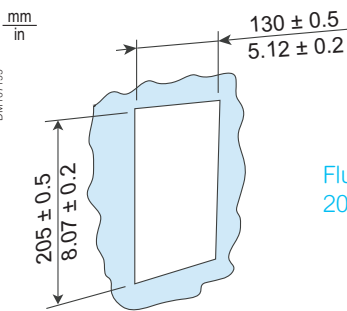

Flush mounting for 20TE model

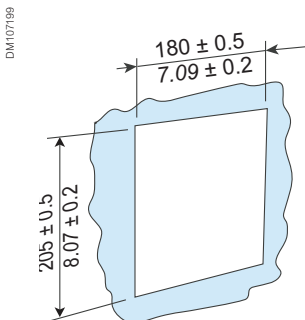

Flush mounting for 30TE model

PowerLogic P5 protection relays are available for flush mounting or rack mounting.

Rack mounting accessories

Rack mounting frames have been designed to have dimensions in accordance with IEC60297 and are supplied ready-to-use. On a standard 483 mm (19") rack system, this enables combinations up to four PowerLogic P5x20 protection relays. If the space is not used, 3 sizes of blanking plates are also available.

REL51020:	Blanking plate 10TE 50.2 mm x 177 mm or 2 in. x 6.97 in
REL51019:	Blanking plate 20TE 103.2 mm x 177 mm or 4 in. x 6.97 in.
REL51018:	Blanking plate 30TE 206.8 mm x 177 mm or 6 in. x 6.97 in.
REL51021:	19 inch rack mounting accessory 483 mm x 178 mm x 78 mm or 7.00 in. x 3.07 in.

Flush mounting accessories

PowerLogic P5 protection relays may be flush mounted using dedicated accessories to help easy and quick installation.

REL51032: 20TE Flush mounting accessory

This reference can be used with all PowerLogic P5x20 protection relays.

REL51052: 30TE Flush mounting accessory

This reference can be used with all PowerLogic P5x30 protection relays.

NOTE:

Please see the appropriate Safety Guide or User Guide for correct installation information.

Services

Services

Greater peace of mind throughout your installation lifecycle	104
On-site condition maintenance with ProDiag MV Relay	105
Achieve higher sustainability with ECOFIT™ solutions	106
Environmental information with Green Premium™ ecolabel	107

Greater peace of mind throughout your installation lifecycle

How can you reduce costs and improve performance at the same time?

When it comes to your electrical distribution infrastructure, the answer is straightforward: get professional expertise.

Life cycle services

DM108843

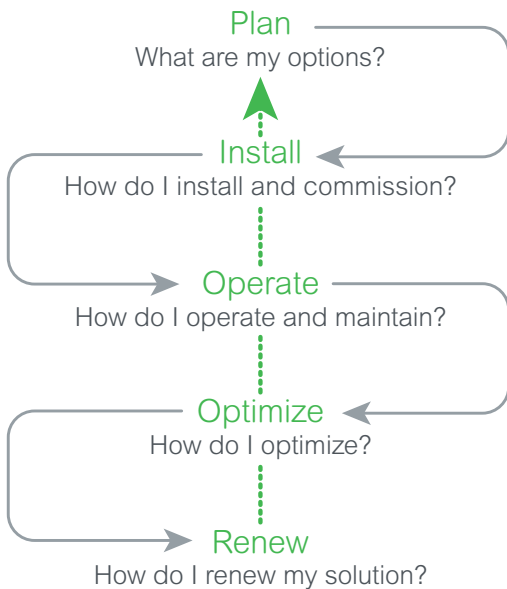

When it comes to your electrical distribution installation, we can help you:

- Increase productivity, reliability, and safety
- Mitigate risk and limit downtime
- Keep equipment up to date and extend lifespan
- Cut cost and increase savings
- Improve your return on investment

CONTACT US!

<https://www.se.com/ww/en/work/services/field-services/electrical-distribution/>

Plan

Schneider Electric helps you plan the full design and execution of your solution, looking at how to make your process more dependable and optimize time:

- **Technical feasibility studies:** Design solution in your environment.
- **Preliminary design:** Accelerate turnaround time to reach a final solution design.

Install

Schneider Electric will help you to install more efficient, more reliable and safer solutions based on your plans:

- **Project management:** Complete your projects on time and within budget.
- **Commissioning:** Ensure your actual performance versus design, through on-site testing and commissioning, and tools and procedures.

Operate

Schneider Electric helps you maximize your installation uptime and control your capital expenditures through its services offering:

- **Asset operation solutions:** Provide the information you need to increase safety, enhance installation performance, and optimize asset maintenance and investment.
- **Advantage service plans:** Customize service plans that include preventive, predictive and corrective maintenance.
- **On-site maintenance services:** Deliver extensive knowledge and experience in electrical distribution maintenance.
- **Spare parts management:** Ensure spare parts availability and optimized maintenance budget of your spare parts.
- **Technical training:** Build necessary skills and competencies to properly and safely operate your installations.

Optimize

Schneider Electric proposes recommendations for improved safety, availability, reliability and quality:

- **MP4 electrical assessment:** Define an improvement and risk management program.

Renew

We extend the life of your system while providing upgrades and we can even offer to take full responsibility for the end-of-life processing of old electrical equipment:

- **Retrofit:** Keep up to date and improve the performance of electrical installations.
- **MV product end of life:** Recycle and recover outdated equipment with end-of-life services.

On-site condition maintenance with ProDiag MV Relay

DM107178



Why carry out diagnostics?

Business competitiveness depends strongly on productivity, and productivity means uptime. On-site condition maintenance, with regular diagnostics, provides a long-term solution to avoid downtime.

Why perform PowerLogic relay diagnostics with Schneider Electric?

Schneider Electric offers a complete range of maintenance services to provide you with the necessary level of maintenance for your PowerLogic devices. Having Schneider Electric at your side means our highly qualified personal can perform the right maintenance, while complying with manufacturer procedures and international services.

Diagnosing protection relay tripping capability

The **ProDiag MV Relay** diagnostic solution should be used on MV protection relays that have not received any diagnostics within the last four years.

This diagnostic checks the protection relay's conformity against the original product specifications to ensure that they meet their goals of:

- Reducing risks by isolating hazardous segments of the network where an electrical fault has been detected
- Maintaining high energy availability to avoid a total power outage and costly downtime
- Maximizing uptime by performing in-depth analysis and de-energizing equipment only when absolutely necessary

ProDiag MV Relay's unique features:

- Automatic download of all protection relay settings through drivers in the ProDiag MV Relay manager
- Easy verification of modifications made to protection settings since the last visit
- Easy verification of MV Relay original technical specifications

ProDiag MV Relay: Included in the extended 10-year warranty*

The PowerLogic P5 extended 10-year warranty applies under the following conditions:

- The product is registered within 18 months. Simply use the "My Schneider" app to scan the QR code found on the front of your PowerLogic P5
- The ProDiag MV Relay diagnostic is performed every FOUR YEARS (when PowerLogic P5 is used under normal operating conditions)
- Any replaced or repaired products have the latest hardware and firmware versions, and are functionally compliant with the original product



* Standard warranty 2 years.

Please check with your local Schneider Electric representative for extended warranty availability and conditions.

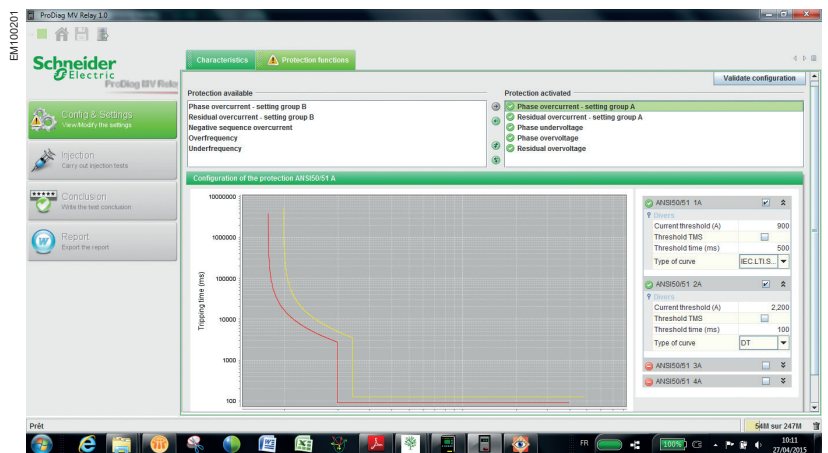

Achieve higher sustainability with ECOFIT™ solutions



Modernizing and upgrading your medium voltage switchgear doesn't need to mean destroying your existing infrastructure.

Schneider Electric retrofit solutions, combined with proper switchgear maintenance helps you to improve the reliability of your installation while achieving higher sustainable performance with ECOFIT™ - a Green Premium™ service.

ECOFIT™ for your MV Switchboard

- Extend your switchgears lifetime
- Access asset and energy management with digitization
- Reduce your environmental impact
- Enhance your process dependability
- Optimize your maintenance service costs and limit your investment
- New ECOFIT™ spare parts availability.

A true extended life time with ECOFIT™ protection relays

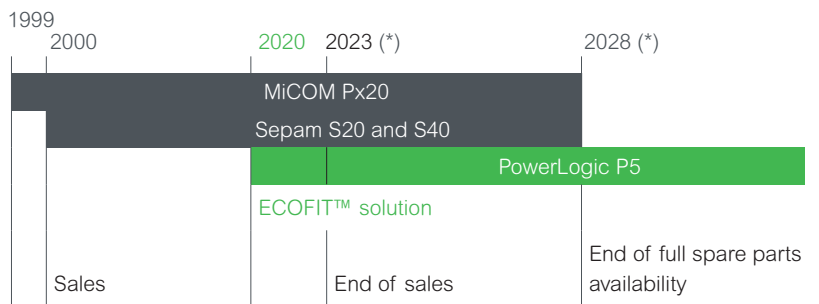

(*) Please consult Schneider Electric

ECOFIT™ offers:

	Sepam S20	Sepam S40	MiCOM Px20	PowerLogic P5
Case	Flush mounting	Flush mounting	Flush mounting	Flush mounting
Installation	Fixed case	Fixed case	Withdrawable case	Withdrawable case
Language	Multilanguage	Multilanguage	Multilanguage	Multilanguage
Communication	IEC 60870-5-103 DNP3 Modbus serial	IEC 61850 Station bus IEC 60870-5-103 DNP3 Modbus serial Modbus Ethernet	Modbus serial Kbus Courier IEC60870-5-103 DNP3	IEC 61850 Ed.1 & Ed.2 IEC 60870-5-103 & 101 DNP3 Ethernet DNP3 serial Modbus Ethernet Modbus serial EtherNet/IP
Power supply	24 - 250 Vdc 48 - 240 Vac	24 - 250 Vdc 48 - 240 Vac	24 - 250 Vdc 48 - 240 Vac	48 - 250 Vdc 100 - 230 Vac
Control LED	11 LEDs	11 LEDs	8 LEDs	PowerLogic P5x20: 10 LEDs PowerLogic P5x30: 14 LEDs
Cybersecurity	No	No	No	Yes
Arc-flash protection	No	No	No	PowerLogic P5x30: 0 to 6 sensors
Back up memory	No	No	No	Yes
Compatibility with	PowerLogic P5x20: S20 / S24 / T20 / T24 / B21 / B22 / M20	PowerLogic P5x30: S40 / S41 / S42 / S43 / S44 / S50 / S51 / S52 / S53 / S54 / T40 / T42 / T50 / T52 / M40 / M41 / G40	PowerLogic P5x20: P120 / P121 / P122 / P123 / P921 / P922 / P923 / P721 / P723 / P920 PowerLogic P5x30: P126 / P127 / P225 / P521 / P220 / P125	

Environmental information with Green Premium™ ecolabel

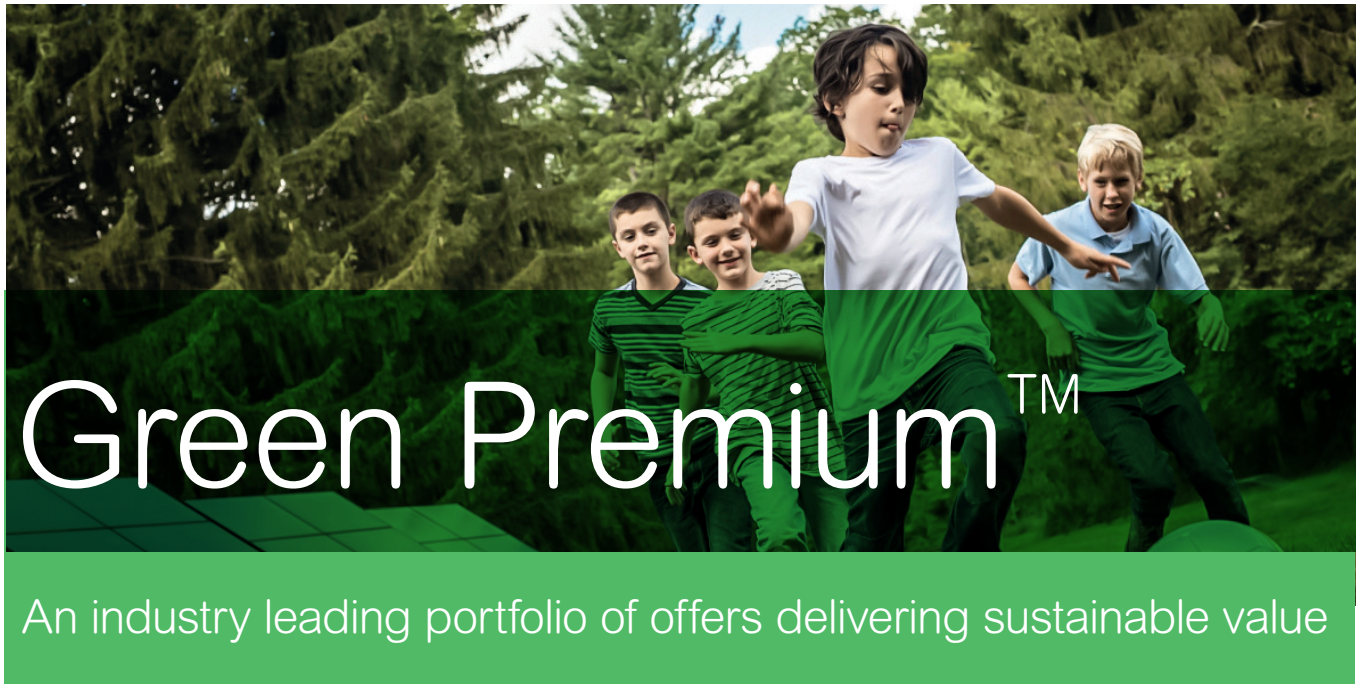

More than 75% of our product sales offer superior transparency on the material content, regulatory information and environmental impact of our products:

- RoHS compliance
- REACH substance information
- Industry leading # of PEP's*
- Circularity instructions



Discover what we mean by green
[Check your products!](#)

The Green Premium program stands for our commitment to deliver customer valued sustainable performance. It has been upgraded with recognized environmental claims and extended to cover all offers including Products, Services and Solutions.

CO₂ and P&L impact through... Resource Performance

Green Premium brings improved resource efficiency throughout an asset's lifecycle. This includes efficient use of energy and natural resources, along with the minimization of CO₂ emissions.

Cost of ownership optimization through... Circular Performance

We're helping our customers optimize the total cost of ownership of their assets. To do this, we provide IoT-enabled solutions, as well as upgrade, repair, retrofit, and remanufacture services.

Peace of mind through... Well-being Performance

Green Premium products are RoHS and REACH compliant. We're going beyond regulatory compliance with step-by-step substitution of certain materials and substances from our products.

Improved sales through... Differentiation

Green Premium delivers strong value propositions through third-party labels and services. By collaborating with third-party organizations we can support our customers in meeting their sustainability goals such as green building certifications.

*PEP: Product Environmental Profile (i.e. Environmental Product Declaration)

Ordering

Ordering

PowerLogic P5 Configurator	110
<hr/>	
Ready-to-use Configuration	111
PowerLogic P5x20 ordering variants	111
PowerLogic P5x30 ordering variants	112
Additional modules ordering variants	113
Accessories ordering variants	114
<hr/>	
Tools	115
<hr/>	

PowerLogic P5 CONFIGURATOR:
The unique web tool to quickly and
easily configure your PowerLogic P5.

Fast and Simple

See more on:

- www.se.com/PowerLogic-p5

Or click directly on: [help me choose tool](#)

The screenshot shows the 'Select your PowerLogic™ P5' configuration tool. The main area is titled 'Select Characteristics' and 'P5F30 Directional Feeder and Transformer protection'. It features several sections for configuration: 'Hardware' (Measuring inputs, Power supply, Additional digital inputs and outputs 1, Additional digital inputs and outputs 3), 'Communication capabilities', and 'Functions, language and version'. Each section has a progress indicator (e.g., 0/4, 1/3) and a 'Reset' button. On the right, a 'My solution' panel shows 'PowerLogic™ P5' with a list of parts: 'REL50238' (Feeder application license for PowerLogic P5F... x1) and 'REL50200' (Latest firmware version for PowerLogic P5 x1). A message states 'Your configuration is not yet complete. Please select some characteristics' and includes a 'Load an existing configuration' button. At the bottom right, a green bar shows '2 Items' and an 'Add to Cart' button.

PowerLogic P5x20 ordering variants

- Please indicate the Part No. (for example: **REL50333**) to your Schneider Electric correspondent
- For other variants please contact your Schneider Electric correspondent
- Click on the specific Part No. to visit a dedicated web page and download the datasheet

The order forms can be used to define PowerLogic P5 accessories.

Part No.	Qty.	Designation
PowerLogic P5U20 Current relay - 24-250 V		
REL50301	<input type="checkbox"/>	P5U20-AABA-BAAAA-AAEA 3CT 2lo + 4DI-4DO, no communication, no extension + settable cybersecurity
REL50302	<input type="checkbox"/>	P5U20-AABA-CAAAA-AAEA 3CT 1CSH + 4DI-4DO, no communication, no extension + settable cybersecurity
REL50303	<input type="checkbox"/>	P5U20-AABB-BAAAA-AAEA 3CT 2lo + 10DI-8DO, no communication, no extension + settable cybersecurity
REL50304	<input type="checkbox"/>	P5U20-AABB-CAAAA-AAEA 3CT 1CSH + 10DI-8DO, no communication, no extension + settable cybersecurity
REL50331	<input type="checkbox"/>	P5U20-AABA-BABAH-AAEA 3CT 2lo + 4DI-4DO, RSTP Eth RJ45, extension + settable cybersecurity
REL50332	<input type="checkbox"/>	P5U20-AABA-CABAH-AAEA 3CT 1CSH + 4DI-4DO, RSTP Eth RJ45, extension + settable cybersecurity
REL50333	<input type="checkbox"/>	P5U20-AABB-BABAH-AAEA 3CT 2lo + 10DI-8DO, RSTP Eth RJ45, extension + settable cybersecurity
REL50334	<input type="checkbox"/>	P5U20-AABB-CABAH-AAEA 3CT 1CSH + 10DI-8DO, RSTP Eth RJ45, extension + settable cybersecurity
PowerLogic P5V20 Voltage relay - 24-250 V		
REL50305	<input type="checkbox"/>	P5V20-AABA-DAAAA-AAEA 4VT + 4DI-4DO + no communication + no extension + settable cybersecurity
REL50306	<input type="checkbox"/>	P5V20-AABB-DAAAA-AAEA 4VT + 10DI-8DO + no communication + no extension + settable cybersecurity
REL50339	<input type="checkbox"/>	P5V20-AABA-DABAH-AAEA 4VT + 4DI-4DO + RSTP Eth RJ45 + extension + settable cybersecurity
REL50340	<input type="checkbox"/>	P5V20-AABB-DABAH-AAEA 4VT + 10DI-8DO + RSTP Eth RJ45 + extension + settable cybersecurity

NOTE:

See your Schneider Electric representative for complete ordering information.

PowerLogic P5x30 ordering variants

- Please indicate the Part No. (for example: **REL50453**) to your Schneider Electric correspondent
- For other variants please contact your Schneider Electric correspondent
- Click on the specific Part No. to visit a dedicated web page and download the datasheet.

The order forms can be used to define PowerLogic P5 accessories.

Part No.	Qty.	Designation
PowerLogic P5F30 Feeder protection relay - 48-250 V		
REL50401	<input type="checkbox"/>	P5F30-AACB-GAAAA-AAEA 3CT + 2lo + 4VT + 10DI-8DO + no communication + no extension + settable cybersecurity
REL50402	<input type="checkbox"/>	P5F30-AACB-HAAAA-AAEA 3CT + 1CSH + 4VT + 10DI-8DO + no communication + no extension + settable cybersecurity
REL50404	<input type="checkbox"/>	P5F30-BACB-GAAAA-AAEA 3CT + 2lo + 4VT + 16DI-12DO + no communication + no extension + settable cybersecurity
REL50405	<input type="checkbox"/>	P5F30-BACB-HAAAA-AAEA 3CT + 1CSH + 4VT + 16DI-12DO + no communication + no extension + settable cybersecurity
REL50451	<input type="checkbox"/>	P5F30-AACB-GABAH-AAEA 3CT + 2lo + 4VT + 10DI-8DO + RSTP Eth RJ45 + extension + settable cybersecurity
REL50452	<input type="checkbox"/>	P5F30-AACB-HABAH-AAEA 3CT + 1CSH + 4VT + 10DI-8DO + RSTP Eth RJ45 + extension + settable cybersecurity
REL50453	<input type="checkbox"/>	P5F30-BACB-GABAH-AAEA 3CT + 2lo + 4VT + 16DI-12DO + RSTP Eth RJ45 + extension + settable cybersecurity
REL50454	<input type="checkbox"/>	P5F30-BACB-HABAH-AAEA 3CT + 1CSH + 4VT + 16DI-12DO + RSTP Eth RJ45 + extension + settable cybersecurity
REL50403	<input type="checkbox"/>	P5F30-AACB-IAAAA-AAEA 3LPCT + 1CSH + 4LPVT + 10DI-8DO + no comm + no extension + settable cybersecurity
REL50406	<input type="checkbox"/>	P5F30-BACB-IAAAA-AAEA 3LPCT + 1CSH + 4LPVT + 16DI-12DO + no comm + no extension + settable cybersecurity
PowerLogic P5M30 Motor protection relay- 48-250 V		
REL50407	<input type="checkbox"/>	P5M30-AACB-GAAAA-AAEA 3CT + 2lo + 4VT + 10DI-8DO + no communication + no extension + settable cybersecurity
REL50408	<input type="checkbox"/>	P5M30-AACB-HAAAA-AAEA 3CT + 1CSH + 4VT + 10DI-8DO + no communication + no extension + settable cybersecurity
REL50410	<input type="checkbox"/>	P5M30-BACB-GAAAA-AAEA 3CT + 2lo + 4VT + 16DI-12DO + no communication + no extension + settable cybersecurity
REL50411	<input type="checkbox"/>	P5M30-BACB-HAAAA-AAEA 3CT + 1CSH + 4VT + 16DI-12DO + no communication + no extension + settable cybersecurity
REL50455	<input type="checkbox"/>	P5M30-AACB-GABAH-AAEA 3CT + 2lo + 4VT + 10DI-8DO + RSTP Eth RJ45 + extension + settable cybersecurity
REL50456	<input type="checkbox"/>	P5M30-AACB-HABAH-AAEA 3CT + 1CSH + 4VT + 10DI-8DO + RSTP Eth RJ45 + extension + settable cybersecurity
REL50457	<input type="checkbox"/>	P5M30-BACB-GABAH-AAEA 3CT + 2lo + 4VT + 16DI-12DO + RSTP Eth RJ45 + extension + settable cybersecurity
REL50458	<input type="checkbox"/>	P5M30-BACB-HABAH-AAEA 3CT + 1CSH + 4VT + 16DI-12DO + RSTP Eth RJ45 + extension + settable cybersecurity
REL50409	<input type="checkbox"/>	P5M30-AACB-IAAAA-AAEA 3LPCT + 1CSH + 4LPVT + 10DI-8DO + no comm + no extension + settable cybersecurity
REL50412	<input type="checkbox"/>	P5M30-BACB-IAAAA-AAEA 3LPCT + 1CSH + 4LPVT + 16DI-12DO + no comm + no extension + settable cybersecurity
PowerLogic P5T30 Transformer differential relay 24-48 V		
REL50493	<input type="checkbox"/>	P5T30-AADB-JAAAA-AAEA 6CT + 2lo + 1VT + 10DI-8DO + no communication + no extension + settable cybersecurity
REL50495	<input type="checkbox"/>	P5T30-BADD-JAAAA-AAEA 6CT + 2lo + 1VT + 15DI-13DO + no communication + no extension + settable cybersecurity
REL50497	<input type="checkbox"/>	P5T30-CBDD-JABAH-AAEA 6CT + 2lo + 1VT + 18DI-16DO + 3 arc + RSTP Eth RJ45 + extension + settable cybersecurity
PowerLogic P5T30 Transformer differential relay 48-250 V		
REL50494	<input type="checkbox"/>	P5T30-AACB-JAAAA-AAEA 6CT + 2lo + 1VT + 10DI-8DO + no communication + no extension + settable cybersecurity
REL50496	<input type="checkbox"/>	P5T30-BACD-JAAAA-AAEA 6CT + 2lo + 1VT + 15DI-13DO + no communication + no extension + settable cybersecurity
REL50498	<input type="checkbox"/>	P5T30-CBCD-JABAH-AAEA 6CT + 2lo + 1VT + 18DI-16DO + 3 arc + RSTP Eth RJ45 + extension + settable cybersecurity

NOTE: See your Schneider Electric representative for complete ordering information.

Additional modules

Part No.	Qty.	Designation
External modules		
REL51038	<input type="checkbox"/>	Ethernet TP module - slot M
REL51039	<input type="checkbox"/>	Ethernet FO module - slot M
REL51042	<input type="checkbox"/>	Ethernet TP module - slot L
REL51033	<input type="checkbox"/>	Ethernet HSR/PRP FO module - slots M and N
REL51036	<input type="checkbox"/>	RS485 serial line module - slot N
VW3A8306RC	<input type="checkbox"/>	RS485 line termination accessory
LV434211	<input type="checkbox"/>	RJ45 to open 2/4 wire adaptor for Modbus
REL51040	<input type="checkbox"/>	Fiber optic serial line module - slot N
REL51034	<input type="checkbox"/>	Extension module - slot P
59641	<input type="checkbox"/>	8 temperature sensor module (MET148-2)
REL51045	<input type="checkbox"/>	IRIG-B module
59660	<input type="checkbox"/>	0.6 m remote module connection cord
59661	<input type="checkbox"/>	2 m remote module connection cord
59662	<input type="checkbox"/>	4 m remote module connection cord
59635	<input type="checkbox"/>	Core balance CT, Ø=120 mm (CSH120)
59636	<input type="checkbox"/>	Core balance CT, Ø=200 mm (CSH200)
59637	<input type="checkbox"/>	Core balance CT, Ø=300 mm (CSH300)
59700	<input type="checkbox"/>	USB cord for PC for eSetup EasergyPro connection
03813519N0	<input type="checkbox"/>	1 phase LPCT TLP130 0,72 kV 130 mm diam 4m cable with intermediary connection
03818034N0	<input type="checkbox"/>	1 phase LPCT TLP130/a 0,72 kV 130 mm diam 6.5 m cable
03811060N0	<input type="checkbox"/>	1 phase LPCT TLP160 0,72 kV 160 mm diam 6.5 m cable
03811061N0	<input type="checkbox"/>	1 phase LPCT TLP190 0,72 kV 190 mm diam 6.5 m cable
03816498N0	<input type="checkbox"/>	1 phase LPVT 20 kV GIS type C (24 kV)
03816686N0	<input type="checkbox"/>	1 phase LPVT 10 kV GIS type C (12 kV)
03816695N0	<input type="checkbox"/>	1 phase LPVT 20 kV GIS type C (24 kV)

Part No.	Qty.	Designation
LPVT36GC	<input type="checkbox"/>	1 phase LPVT 30 kV GIS type C (36 kV)
LPVT17GNKT	<input type="checkbox"/>	1 phase LPVT 10 kV GIS (12 kV) type NKT
LPVT24GNKT	<input type="checkbox"/>	1 phase LPVT 24 kV GIS (24 kV) type NKT
LPVT17GNE	<input type="checkbox"/>	1 phase LPVT 10 kV GIS (12 kV) type NEXANS, short cone
LPVT24GNE	<input type="checkbox"/>	1 phase LPVT 24 kV GIS (24 kV) type NEXANS, short cone
LPVT17A	<input type="checkbox"/>	1 phase LPVT 10kV AIS (12 kV)
LPVT24A	<input type="checkbox"/>	1 phase LPCT 20kV AIS (24 kV)
EMS59572	<input type="checkbox"/>	VT adapter
EMS59573	<input type="checkbox"/>	LPVT hub connector
REL51037*	<input type="checkbox"/>	LPIT Test Box
REL51089*	<input type="checkbox"/>	LPCT Test Socket with cover
REL51090*	<input type="checkbox"/>	LPCT Test Plug
REL51092*	<input type="checkbox"/>	LPVT Test Socket with cover
REL51093*	<input type="checkbox"/>	LPVT Test Plug
P7M12025	<input type="checkbox"/>	LPVT transducer
REL51095*	<input type="checkbox"/>	T-box 3-way RJ45 junction

NOTE: See your Schneider Electric representative for complete ordering information.

* Please contact Schneider Electric for availability.

Sensors for Arc Flash protection

Part No.	Qty.	Designation
REL52801	<input type="checkbox"/>	Arc-flash accessory VA1DA-20 Arc-flash sensor 20 m
REL52802	<input type="checkbox"/>	Arc-flash accessory VA1DA-20S-HF Arc-flash sensor 20 m shielded halogen free
REL52803	<input type="checkbox"/>	Arc-flash accessory VA1DA-20S Arc-flash sensor 20 m shielded
REL52804	<input type="checkbox"/>	Arc-flash accessory VA1DA-6 Arc-flash sensor 6 m connect cable
REL52805	<input type="checkbox"/>	Arc-flash accessory VA1DA-6S-HF Arc-flash sensor 6 m shielded halogen free
REL52806	<input type="checkbox"/>	Arc-flash accessory VA1DA-6S Arc-flash sensor 6 m shielded
REL52807	<input type="checkbox"/>	Arc-flash accessory VA1EH-20 Arc-flash sensor 20 m pipe sensor
REL52808	<input type="checkbox"/>	Arc-flash accessory VA1EH-20S Arc-flash sensor 20 m pipe sensor shielded
REL52809	<input type="checkbox"/>	Arc-flash accessory VA1EH-6 Arc-flash sensor 6 m pipe sensor
REL52810	<input type="checkbox"/>	Arc-flash accessory VA1EH-6S Arc-flash sensor 6 m pipe sensor shielded

Accessories and spare parts

Part No.	Qty.	Designation
Mounting accessories		
REL51032	<input type="checkbox"/>	20TE flush mounting accessory
REL51052	<input type="checkbox"/>	30TE flush mounting accessory
REL51021	<input type="checkbox"/>	19 inch rack mounting accessory
REL51018	<input type="checkbox"/>	30TE blanking plate for rack mounting
REL51019	<input type="checkbox"/>	20TE blanking plate for rack mounting
REL51020	<input type="checkbox"/>	10TE blanking plate for rack mounting
Spare parts		
REL51077	<input type="checkbox"/>	Spare 2 screw type connectors kit for slots B, C, D, E
REL51078	<input type="checkbox"/>	Spare wiring accessories kit for CT/VT version
REL51079	<input type="checkbox"/>	Spare wiring accessories kit for LPCT/LPVT version
REL51088*	<input type="checkbox"/>	Spare cable for LPIT Test Box

NOTE: See your Schneider Electric representative for complete ordering information.
 * Please contact Schneider Electric for availability.



TOOLS

www.se.com

This international web site allows you to access all the Schneider Electric solutions and product information via:

- Comprehensive descriptions
- Range datasheets
- A download area
- Product selectors

You can also access information dedicated to your business and contact your Schneider Electric country support.

Web selector

This site allows you to access the Schneider Electric products in just two clicks via a comprehensive range of datasheets, with direct links to:

- Complete libraries: technical documents, catalogs, FAQs, brochures
- Selection guides from the e-catalog
- Product discovery sites and their animations

You will also find illustrated overviews, news to which you can subscribe, and a list of country contacts.

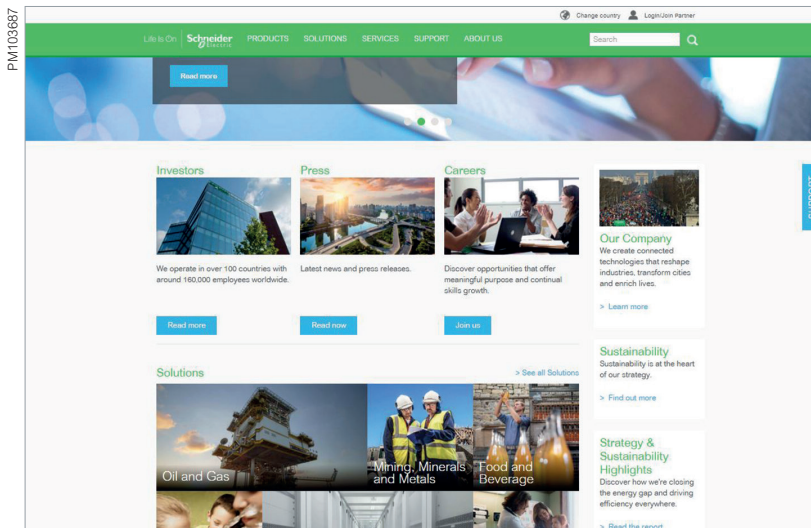

Training

Training allows you to acquire the expertise (installation design, work with power on, etc.) to increase efficiency and improve customer service.

The training catalog includes beginner's courses in electrical distribution, knowledge of MV and LV switchgear, operation and maintenance of installations, and design of LV installations to give a few examples.



www.se.com

Schneider Electric Industries SAS
35, Rue Joseph Monier
CS 30323
92506 Rueil Malmaison Cedex

RCS Nanterre 954 503 439
Capital social 928 298 512 €
www.se.com

June 2023
PowerLogic™ P5
NRJED313567EN

© 2023 - Schneider Electric. All rights reserved.
All trademarks are owned by Schneider Electric
Industries SAS or its affiliated companies.

As standards, specifications and designs develop from time to time, please
ask for confirmation of the information given in this document.

Over 75 % of Schneider Electric products
have been awarded the Green Premium ecolabel.

